

General Description

The MAX32620/MAX32621 is a 32-bit RISC ARM® Cortex®-M4F (M4 plus Floating Point Unit) microcontroller. It is ideally suited for the emerging category of medical and fitness applications. The architecture combines high-efficiency, signal-processing functionality with low cost, and ease of use. The device features 4 powerful & flexible power modes. Built-in dynamic clock gating and firmware controlled power gating minimize power consumption for any application. Multiple SPI, UART, and I²C serial interfaces, as well as a 1-Wire® master and USB, allow for interconnection to a wide variety of external sensors. A four-input, 10-bit ADC with selectable references is provided.

The MAX32621 is a secure version of the MAX32620, incorporating a trust protection unit (TPU) with encryption and advanced security features.

Applications

- Sport Watches
- Fitness Monitors
- Wearable Medical Patches
- Portable Medical Devices
- Sensor Hub

Benefits and Features

- High-Efficiency Microcontroller for Rechargeable Devices
 - Internal Oscillator Operates Up to 96MHz
 - Floating Point Unit
 - Memory Protection Unit
 - 2MB Flash Memory
 - 256KB SRAM
 - 8KB Instruction Cache
 - 1.2V ±5% Core Supply Voltage
 - 1.8V ±5% I/O and Analog Supply Voltage
 - Optional 3.3V ±5% USB Supply Voltage

- Tiny 81-Ball WLP Minimizes Board Space (3.9mm x 3.9 mm WLP, 0.4 mm Pitch)
- Power Management Maximizes Uptime for Battery Applications
 - 95µA/MHz Active Executing from Flash
 - 600nA Low Power (LP0) Mode with RTC Enabled
 - 2.5µA Ultra-Low Power Data Retention Mode (LP1) with Fast 5µs (typ) Wakeup to 96MHz
 - Peripheral Management Unit (PMU) Reduces Power Consumption in Measurement Mode (LP2)
- Optimal Peripheral Mix Provides Platform Scalability
 - Three SPI Masters, Four UARTs, Three I²C Masters, and One 1-Wire Master
 - 49 General-Purpose I/O Pins
 - SPI Execute in Place Engine for Memory Expansion with Minimal Footprint
 - Full-Speed USB 2.0 with Internal Transceiver
 - Sixteen Pulse Train Engines
 - Four-Input, 10-Bit Sigma-Delta ADC Operating at 7.8 kS/s
- Trust Protection Unit (TPU) Secures Valuable IP and Data (MAX32621 Only)
 - Robust Hardware Internal Security
 - High-Speed Modular Arithmetic Accelerator (MAA) Supports Fast ECDSA
 - AES Hardware Engine
 - Hardware PRNG Entropy Generator
 - Secure Boot Loader

Ordering Information, and Additional Features appear at end of data sheet.

ARM is a registered trademark and registered service mark and Cortex is a registered trademark of ARM Limited.
1-Wire is a registered trademark of Maxim Integrated Products, Inc.



MAX32620/MAX32621 Block Diagram

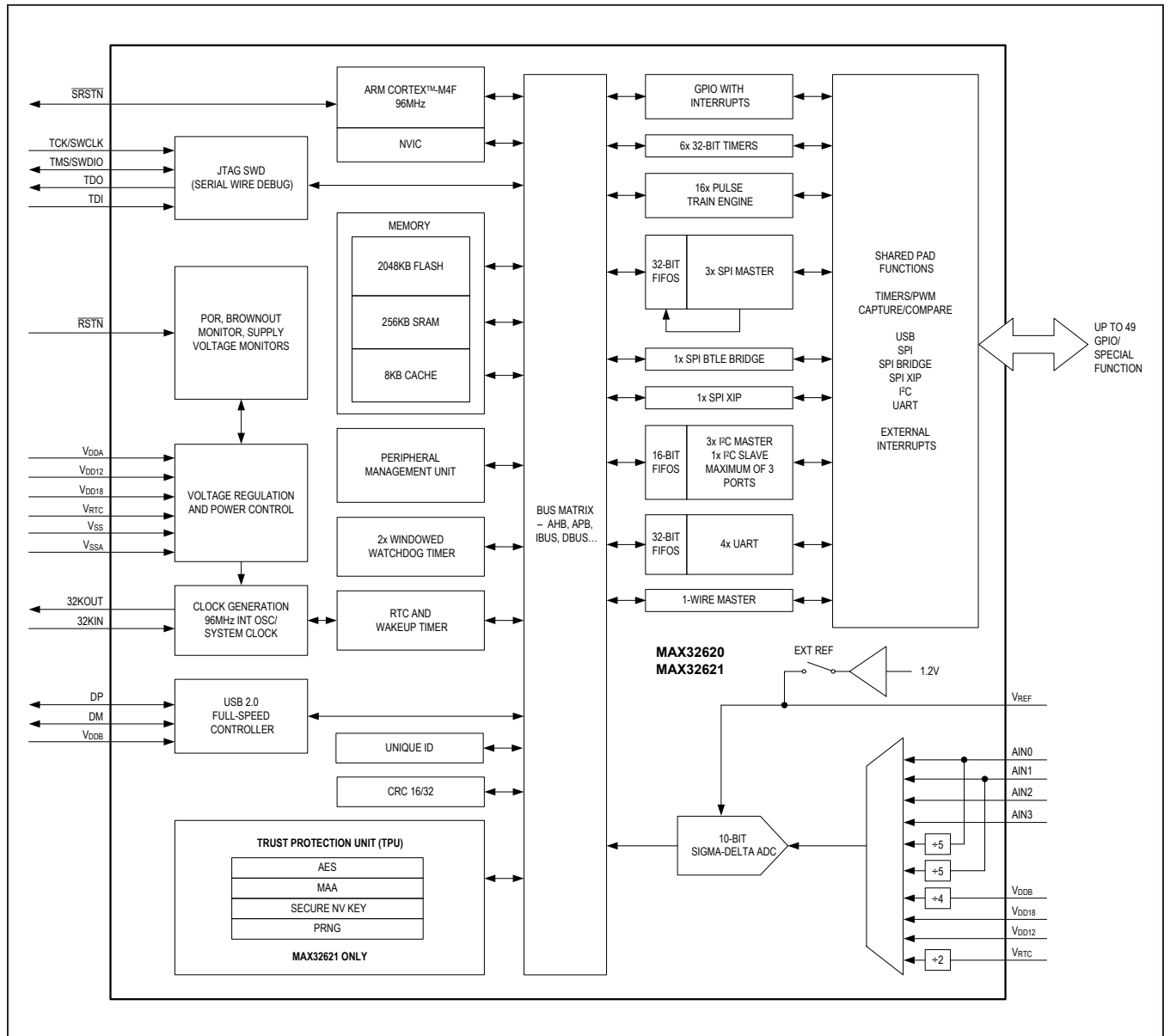

Absolute Maximum Ratings

(All voltages with respect to V_{SS}, unless otherwise noted.)

| | |
|--|-----------------|
| V _{DD18} | -0.3V to +1.89V |
| V _{DD12} | -0.3V to +1.26V |
| V _{DDA} with respect to V _{SS1A} | -0.3V to +1.89V |
| V _{RTC} | -0.3V to +3.6V |
| V _{DDB} | -0.3V to +3.6V |
| V _{REF} | -0.3V to +3.6V |
| 32KIN, 32KOUT | -0.3V to +3.6V |
| RSTN, SRSTN, GPIO | -0.3V to +3.6V |
| AIN[1:0] | -0.3V to +5.5V |
| AIN[3:2] | -0.3V to +3.6V |

| | |
|--|-----------------|
| Total current into V _{DD18} (sink) | 100mA |
| Total current into V _{SS} | 100mA |
| Output current (sink) by Any I/O pin | 25mA |
| Output current (source) by Any I/O pin | -25mA |
| Continuous Power Dissipation (T _A = +70°C) TQFP (multilayer board) (derate 45.5mW/°C above +70°C) | 3636.4mW |
| Operating Temperature Range | -20°C to +85°C |
| Storage Temperature Range | -65°C to +150°C |
| Soldering Temperature (reflow) | +260°C |

This is a stress rating only and functional operation of the device at these or any other conditions above those indicated in the operation sections of this specification is not implied. Exposure to absolute maximum rating conditions for extended periods of time may affect reliability.

Package Thermal Characteristics (Note 1)

TQFP

| | |
|---|--------|
| Junction-to-Ambient Thermal Resistance (θ _{JA}) | 22°C/W |
| Junction-to-Case Thermal Resistance (θ _{JC}) | 2°C/W |

WLP

| | |
|---|--------|
| Junction-to-Ambient Thermal Resistance (θ _{JA}) | 36°C/W |
|---|--------|

Note 1: Package thermal resistances were obtained using the method described in JEDEC specification JESD51-7, using a four-layer board. For detailed information on package thermal considerations, refer to www.maximintegrated.com/thermal-tutorial.

Electrical Characteristics

(Limits are tested at T_A = +20°C and T_A = +85°C. Limits over the operating temperature range and relevant supply voltage range are guaranteed by design and characterization. Specifications marked GBD are guaranteed by design and not production tested.)

| PARAMETER | SYMBOL | CONDITIONS | MIN | TYP | MAX | UNITS |
|---|------------------------|--|------|------|------|--------|
| Supply Voltage | V _{DD18} | | 1.71 | 1.8 | 1.89 | V |
| | V _{DD12} | | 1.14 | 1.2 | 1.26 | |
| | V _{DDA} | | 1.71 | 1.8 | 1.89 | |
| | V _{RTC} | | 1.71 | 1.8 | 1.89 | |
| | V _{DDB} | | 3.04 | 3.3 | 3.60 | |
| Power-Fail Reset Voltage | V _{RST} | Monitors V _{DD18} | 1.62 | | 1.70 | V |
| Power On Reset Voltage | V _{POR} | Monitors V _{DD18} | | 1.5 | | V |
| RAM Data Retention Voltage | V _{DRV} | | | 0.94 | | V |
| V _{DD12} Dynamic Current, LP3 Mode | I _{DD12_DLP3} | Executing code from cache memory, | | 95 | | µA/MHz |
| V _{DD12} Current, LP3 Mode | I _{DD12_LP3} | System clock stopped | | 490 | | µA |
| V _{DD18} Current, LP3 Mode | I _{DD18_LP3} | Executing code from cache memory, all inputs are tied to V _{SS} or V _{DD18} , outputs do not source/sink any current | | 360 | | µA |

Electrical Characteristics (continued)

(Limits are tested at $T_A = +20^\circ\text{C}$ and $T_A = +85^\circ\text{C}$. Limits over the operating temperature range and relevant supply voltage range are guaranteed by design and characterization. Specifications marked GBD are guaranteed by design and not production tested.)

| PARAMETER | SYMBOL | CONDITIONS | MIN | TYP | MAX | UNITS |
|--|------------------------|---|-------|-------------------|-------|--------|
| V _{RTC} Current, LP3 Mode | I _{RTC_LP3} | RTC disabled | | 105 | | nA |
| | | RTC enabled | | 805 | | nA |
| V _{DD12} Dynamic Current, LP2 Mode | I _{DD12_DLP2} | ARM in sleep mode, PMU with two channels active | | 27 | | μA/MHz |
| V _{DD12} Current, LP2 Mode | I _{DD12_LP2} | ARM in sleep mode, system clock stopped | | 490 | | μA |
| V _{DD18} Current, LP2 Mode | I _{DD18_LP2} | ARM in sleep mode, PMU with two channels active, all inputs are tied to V _{SS} or V _{DD18} , outputs do not source/sink any current | | 360 | | μA |
| V _{RTC} Current, LP2 Mode | I _{RTC_LP2} | RTC disabled | | 105 | | nA |
| | | RTC enabled | | 805 | | nA |
| V _{DD12} Current, LP1 Mode | I _{DD12_LP1} | Standby state with full data retention | | 0 | | μA |
| V _{DD18} Current, LP1 Mode | I _{DD18_LP1} | Standby state with full data retention | | 2.5 | | μA |
| V _{RTC} Current, LP1 Mode | I _{RTC_LP1} | RTC disabled | | 105 | | nA |
| | | RTC enabled | | 505 | | nA |
| V _{DD12} Current, LP0 Mode | I _{DD12_LP0} | | | 0 | | nA |
| V _{DD18} Current, LP0 Mode | I _{DD18_LP0} | | | 120 | | nA |
| V _{RTC} Current, LP0 Mode | I _{RTC_LP0} | RTC disabled | | 105 | | nA |
| | | RTC enabled | | 505 | | nA |
| LP2 Mode Resume Time | t _{LP2_ON} | | | 0 | | μs |
| LP1 Mode Resume Time | t _{LP1_ON} | | | 5 | | μs |
| LP0 Mode Resume Time | t _{LP0_ON} | | | 15 | | μs |
| CLOCKS | | | | | | |
| Internal Relaxation Oscillator Frequency | f _{INTCLK} | Factory default | 94.08 | 96.0 | 97.92 | MHz |
| | | Firmware trimmed, required for USB compliance | 95.76 | 96.0 | 96.24 | MHz |
| System Clock Frequency | f _{CK} | | 0.371 | | 97.92 | MHz |
| System Clock Period | t _{CK} | | | 1/f _{CK} | | |

Electrical Characteristics (continued)

(Limits are tested at $T_A = +20^\circ\text{C}$ and $T_A = +85^\circ\text{C}$. Limits over the operating temperature range and relevant supply voltage range are guaranteed by design and characterization. Specifications marked GBD are guaranteed by design and not production tested.)

| PARAMETER | SYMBOL | CONDITIONS | MIN | TYP | MAX | UNITS |
|---|-----------------|--|-----------------------|--------|-----------------------|---------------|
| RTC Input Frequency | f_{32KIN} | 32kHz watch crystal (6pF) | | 32.768 | | kHz |
| RTC Power Up Time | t_{RTC_ON} | | | 250 | | ms |
| GENERAL PURPOSE I/O | | | | | | |
| Input Low Voltage for \overline{RSTN} , \overline{SRSTN} , and All Port Pins | V_{IL} | | | | $0.3 \times V_{DD18}$ | V |
| Input High Voltage for \overline{RSTN} , \overline{SRSTN} , and All Port Pins | V_{IH} | | $0.7 \times V_{DD18}$ | | | V |
| Input Hysteresis (Schmitt) | V_{IHYS} | | | 100 | | mV |
| Output Low Voltage for All Port Pins | V_{OL} | $I_{OL} = 4\text{mA}$ (normal drive) | | 0.2 | 0.4 | V |
| | | $I_{OL} = 24\text{mA}$ (high drive) | | 0.2 | 0.4 | V |
| Combined I_{OL} , All GPIO | I_{OL_TOTAL} | | | | 48 | mA |
| Output High Voltage for All Port Pins | V_{OH} | $I_{OH} = -2\text{mA}$ (normal drive) | V_{DD18} | | -0.4 | V |
| | | $I_{OH} = -8\text{mA}$ (high drive) | V_{DD18} | | -0.4 | V |
| Combined I_{OH} , All GPIO | I_{OH_TOTAL} | | | | 48 | mA |
| Input/Output Pin Capacitance for All Port Pins | C_{IO} | | | 5 | | pF |
| Input Leakage Current Low | I_{IL} | $V_{DD18} = 1.89\text{V}$, $V_{IN} = 0\text{V}$, internal pullup disabled | -100 | | +100 | nA |
| Input Leakage Current High | I_{IH} | $V_{DD18} = 1.89\text{V}$, $V_{IN} = 1.89\text{V}$, internal pulldown disabled | -100 | | +100 | nA |
| | I_{OFF} | $V_{DD18} = 0\text{V}$, $V_{IN} < 1.89\text{V}$ | -1 | | +1 | μA |
| | I_{IH3V} | $V_{DD18} = 1.71\text{V}$, $V_{IN} = 3.60\text{V}$ | -1 | | +1 | μA |
| Input Pullup Resistor \overline{RSTN} , \overline{SRSTN} , TMS, TCK, TDI | R_{PU} | | | 25 | | k Ω |
| Input Pullup/Pulldown All GPIO | R_{PU_GPIO} | Normal resistance mode | | 25 | | k Ω |
| | | Highest resistance mode | | 1 | | M Ω |
| FLASH MEMORY | | | | | | |
| Page Size | | | | 8 | | kB |
| Flash Erase Time | t_{M_ERASE} | Mass erase | | 30 | | ms |
| | t_{P_ERASE} | Page erase | | 30 | | ms |
| Flash Programming Time Per Word | t_{PROG} | | | 60 | | μs |
| Flash Endurance | | | 10 | | | kcycles |
| Data Retention | t_{RET} | $T_A = +85^\circ\text{C}$ | 10 | | | years |

USB Electrical Characteristics

(Limits are tested at $T_A = +20^\circ\text{C}$ and $T_A = +85^\circ\text{C}$. Limits over the operating temperature range and relevant supply voltage range are guaranteed by design and characterization. Specifications marked GBD are guaranteed by design and not production tested.)

| PARAMETER | SYMBOL | CONDITIONS | MIN | TYP | MAX | UNITS |
|--|------------|---|-------|-----|-------|------------------|
| Single-Ended Input High Voltage DP, DM | V_{IHD} | | 2.0 | | | V |
| Single-Ended Input Low Voltage DP, DM | V_{ILD} | | | | 0.8 | V |
| Output Low Voltage DP, DM | V_{OLD} | $R_L = 1.5\text{k}\Omega$ from DP to 3.6V | | | 0.3 | V |
| Output High Voltage DP, DM | V_{OHD} | $R_L = 15\text{k}\Omega$ from DP and DM to V_{SS} | 2.8 | | | V |
| Differential Input Sensitivity DP, DM | V_{DI} | DP to DM | 0.2 | | | V |
| Common-Mode Voltage Range | V_{CM} | Includes V_{DI} range | 0.8 | | 2.5 | V |
| Single-Ended Receiver Threshold | V_{SE} | | 0.8 | | 2.0 | V |
| Single-Ended Receiver Hysteresis | V_{SEH} | | | 200 | | mV |
| Differential Output Signal Cross-Point Voltage | V_{CRS} | $C_L = 50\text{pF}$, GBD | 1.3 | | 2.0 | V |
| DP, DM Off-State Input Impedance | R_{LZ} | | 300 | | | $\text{k}\Omega$ |
| Driver Output Impedance | R_{DRV} | Steady-state drive | 28 | | 44 | Ω |
| DP Pullup Resistor | R_{PU} | Idle | 0.9 | | 1.575 | $\text{k}\Omega$ |
| | | Receiving | 1.425 | | 3.090 | |
| USB TIMING | | | | | | |
| DP, DM Rise Time (Transmit) | t_R | $C_L = 50\text{pF}$, GBD | 4 | | 20 | ns |
| DP, DM Fall Time (Transmit) | t_F | $C_L = 50\text{pF}$, GBD | 4 | | 20 | ns |
| Rise/Fall Time Matching (Transmit) | t_R, t_F | $C_L = 50\text{pF}$, GBD | 90 | | 110 | % |

ADC Electrical Characteristics

(Limits are tested at $T_A = +20^\circ\text{C}$ and $T_A = +85^\circ\text{C}$. Limits over the operating temperature range and relevant supply voltage range are guaranteed by design and characterization. Specifications marked GBD are guaranteed by design and not production tested.)

| PARAMETER | SYMBOL | CONDITIONS | MIN | TYP | MAX | UNITS |
|---------------------|------------|---|----------|--------------|-------------------------|---------------|
| Resolution | | | | 10 | | bits |
| ADC Clock Rate | f_{ACLK} | | 0.1 | | 8 | MHz |
| ADC Clock Period | t_{ACLK} | | | $1/f_{ACLK}$ | | μs |
| Input Voltage Range | V_{AIN} | $A_{IN}[3:0]$, $ADC_CHSEL = 0-3$, $BUF_BYPASS = 1$ | V_{SS} | | V_{DDA} | V |
| | | $A_{IN}[1:0]$, $ADC_CHSEL = 4-5$, $BUF_BYPASS = 1$ | V_{SS} | | 5.5V | |
| | | $A_{IN}[3:0]$, $ADC_CHSEL = 0-3$, $BUF_BYPASS = 0$ | 50mV | | $V_{DDA} - 50\text{mV}$ | |
| | | $A_{IN}[1:0]$, $ADC_CHSEL = 4-5$, $BUF_BYPASS = 0$ | 50mV | | 5.5V | |

ADC Electrical Characteristics (continued)

(Limits are tested at $T_A = +20^\circ\text{C}$ and $T_A = +85^\circ\text{C}$. Limits over the operating temperature range and relevant supply voltage range are guaranteed by design and characterization. Specifications marked GBD are guaranteed by design and not production tested.)

| PARAMETER | SYMBOL | CONDITIONS | MIN | TYP | MAX | UNITS |
|---|-----------------|--|------|---------|---------|-----------------------|
| Input Impedance | R_{AIN} | AIN[1:0], ADC_HSEL = 4–5, ADC active | | 45 | | k Ω |
| Input Dynamic Current, Switched Capacitance | I_{AIN} | ADC active, ADC buffer bypassed | | 4.5 | | μA |
| | | ADC active, ADC buffer enabled | | 50 | | nA |
| Analog Input Capacitance | C_{AIN} | Fixed capacitance to ground | | 1 | | pF |
| | | Dynamically switched capacitance | | 250 | | nF |
| Integral Nonlinearity | INL | | | | ± 2 | LSb |
| Differential Nonlinearity | DNL | | | | ± 1 | LSb |
| Offset Error | V_{OS} | | | ± 1 | | LSb |
| Gain Error | GE | | | ± 2 | | LSb |
| ADC Active Current | I_{ADC} | ADC active, reference buffer enabled, input buffer disabled | | 240 | | μA |
| Input Buffer Active Current | I_{INBUF} | | | 53 | | μA |
| ADC Setup Time | t_{ADC_SU} | Any power-up of: ADC clock, ADC bias, reference buffer, or input buffer to CpuAdcStart | | | 10 | μs |
| | | Any power-up of: ADC clock or ADC bias to CpuAdcStart | | | 48 | t_{ACLK} |
| ADC Output Latency | t_{ADC} | | | 1025 | | t_{ACLK} |
| ADC Sample Rate | f_{ADC} | | | | 7.80 | ksps |
| ADC Input Leakage | I_{ADC_LEAK} | AIN0 or AIN1, ADC inactive or channel not selected | | 0.12 | 4 | nA |
| | | AIN2 or AIN3, ADC inactive or channel not selected | | 0.02 | 1.0 | nA |
| AIN0/AIN1 Resistor Divider Error | | ADC_CHSEL = 4 or 5, not including ADC offset/gain error | | ± 2 | | LSb |
| Full-Scale Voltage | V_{FS} | ADC code = 0x3FF | | 1.200 | | V |
| Signal to Noise Ratio | SNR | | | 58.5 | | dB |
| Signal to Noise and Distortion | SINAD | | | 58.5 | | dB |
| Total Harmonic Distortion | THD | | | -68.5 | | dB |
| Spurious Free Dynamic Range | SFDR | | | 74 | | dB |
| Bandgap Temperature Coefficient | V_{TEMPCO} | Box method | | 30 | | ppm/ $^\circ\text{C}$ |
| Reference Input Capacitance | C_{REF_IN} | Dynamically switched capacitance, ADC_XREF=1, ADC active | | 250 | | fF |
| External Reference Voltage | V_{REF_EXT} | ADC_XREF = 1 | 1.17 | 1.23 | 1.29 | V |
| Reference Dynamic Current | I_{REF_EXT} | ADC_XREF=1, ADC active | | 4.1 | | μA |

Pin Configuration

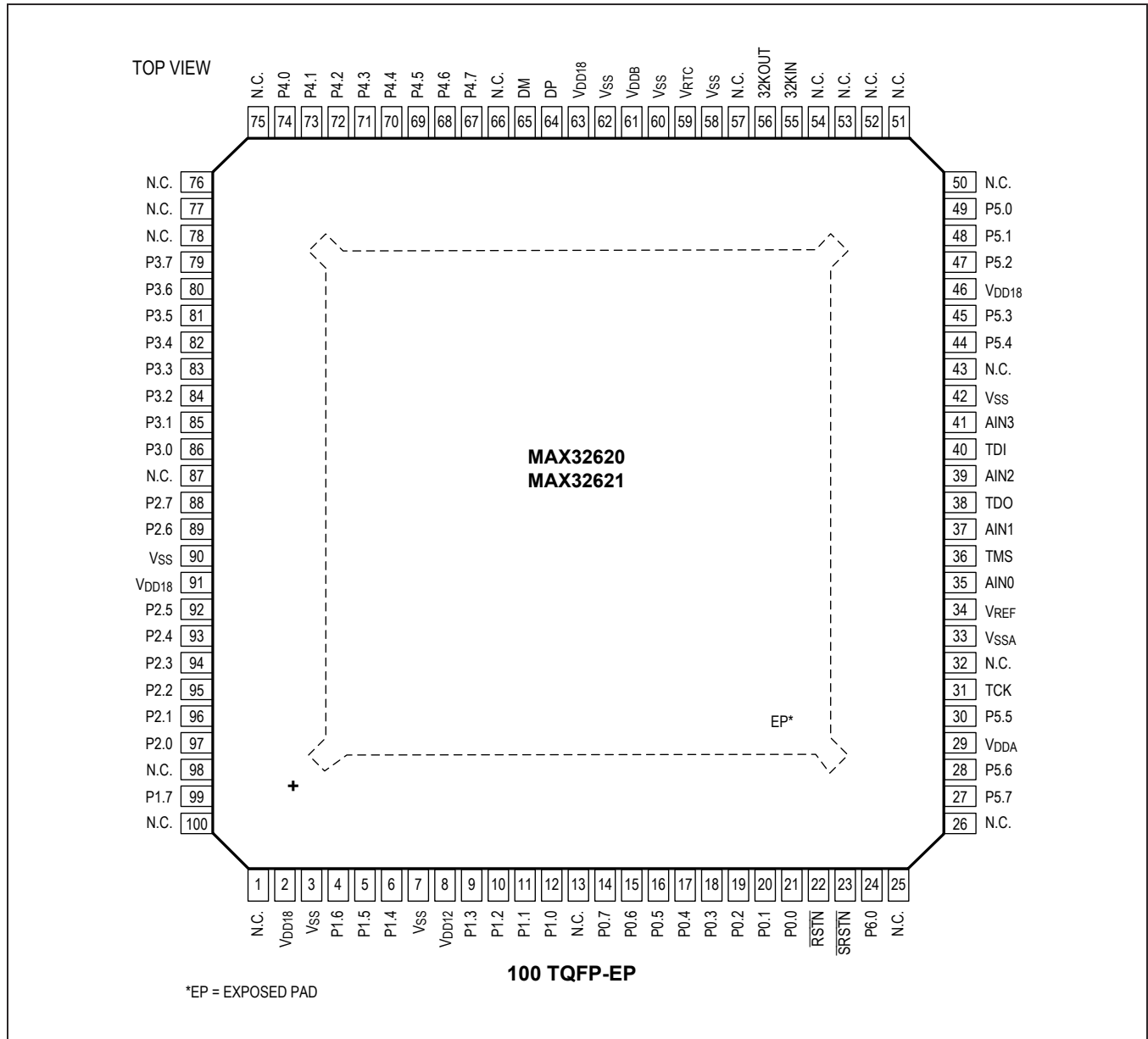

Pin Configuration (continued)

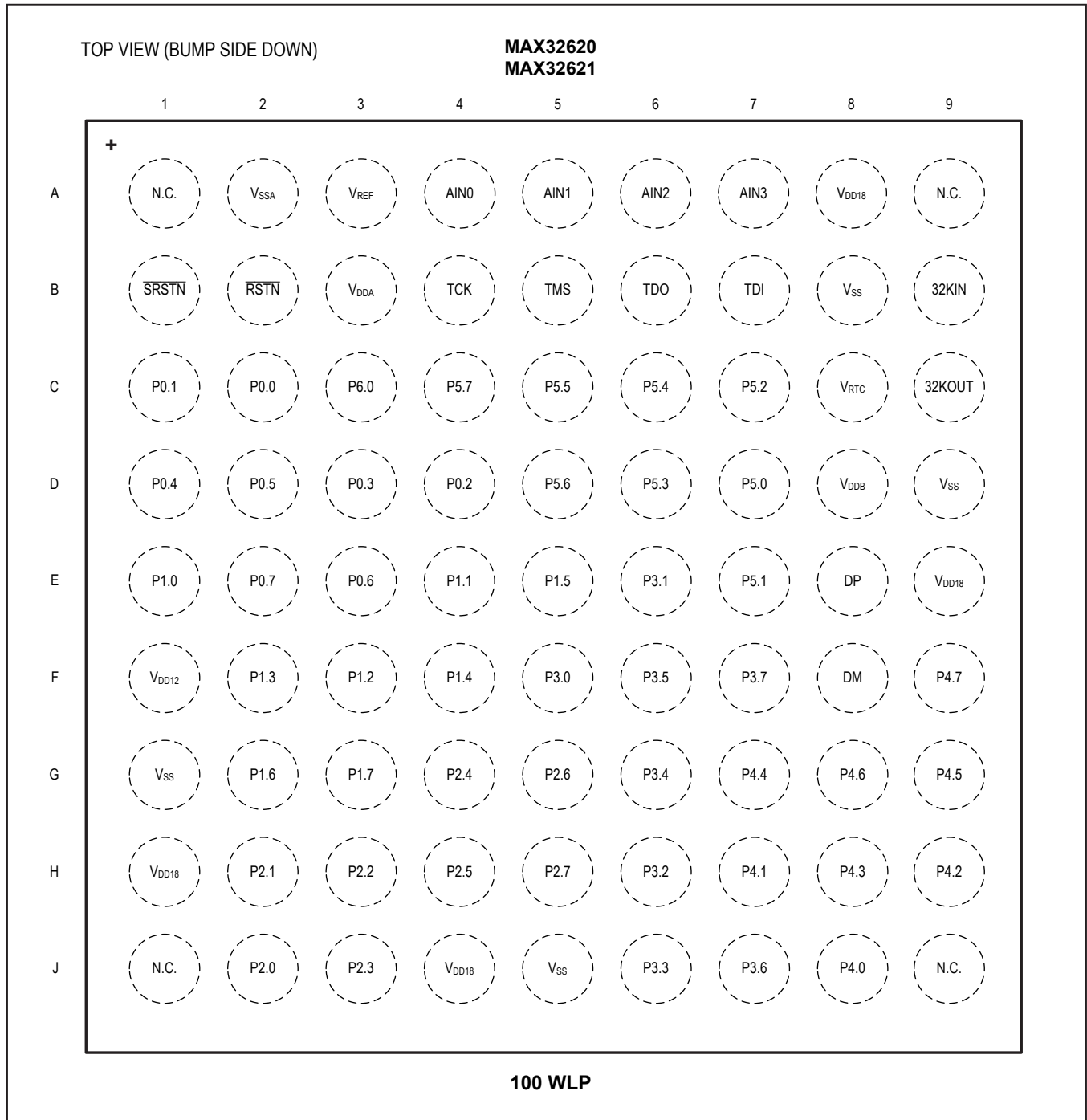

Pin Description

| PIN | | NAME | FUNCTION |
|--------------------------|----------------|-------------------|--|
| TQFP | WLP | | |
| POWER | | | |
| 61 | D8 | V _{DDB} | USB Transceiver Supply Voltage. This pin must be bypassed to V _{SS} with a 1.0μF capacitor as close to this pin as possible. |
| 8 | F1 | V _{DD12} | 1.2V Supply Voltage. This pin must be bypassed to V _{SS} with a 100nF capacitor as close to this pin as possible. |
| 59 | C8 | V _{RTC} | RTC Supply Voltage. This pin must be bypassed to V _{SS} with a 1.0μF capacitor as close to this pin as possible. |
| 29 | B3 | V _{DDA} | Analog Supply Voltage. This pin must be bypassed to V _{SSA} with a 1.0μF capacitor as close to this pin as possible. |
| 2, 46, 63, 91 | A8, E9, H1, J4 | V _{DD18} | 1.8V Supply Voltage. This pin must be bypassed to V _{SS} with a 1.0μF capacitor as close to this pin as possible. |
| 34 | A3 | V _{REF} | ADC Reference. This pin should be left unconnected if an external reference is not used. |
| 3, 7, 42, 58, 60, 62, 90 | B8, D9, G1, J5 | V _{SS} | Digital Ground. |
| 33 | A2 | V _{SSA} | Analog Ground. This pin must be connected to V _{SS} . |
| — | — | EP | Exposed Pad (TQFP Only). This pad must be connected to V _{SS} . Refer to Application Note 3273: Exposed Pads: A Brief Introduction for additional information. |
| CLOCKS | | | |
| 55 | B9 | 32KIN | 32kHz Crystal Oscillator Input/Output. Connect a 6pF 32kHz crystal between 32KIN and 32KOUT for RTC operation. Optionally, an external clock source can be driven on 32KIN if the 32KOUT pin is left unconnected. A 32kHz crystal or external clock source is required for proper USB operation. |
| 56 | C9 | 32KOUT | |
| USB | | | |
| 64 | E8 | DP | USB D+ Signal. This bidirectional pin carries the positive differential data or single-ended data. This pin is weakly pulled high internally when the USB is disabled. |
| 65 | F8 | DM | USB D- Signal. This bidirectional pin carries the negative differential data or single-ended data. This pin is weakly pulled high internally when the USB is disabled. |
| JTAG | | | |
| 31 | B4 | TCK | JTAG Clock or Serial Wire Debug Clock. This pin has an internal 25kΩ pullup to V _{DD18} . |
| 36 | B5 | TMS | JTAG Test Mode Select or Serial Wire Debug I/O. This pin has an internal 25kΩ pullup to V _{DD18} . |
| 38 | B6 | TDO | JTAG Test Data Output |
| 40 | B7 | TDI | JTAG Test Data Input. This pin has an internal 25kΩ pullup to V _{DD18} . |

Pin Description (continued)

| PIN | | NAME | FUNCTION |
|--|-----|---------------------------|--|
| TQFP | WLP | | |
| RESET | | | |
| 22 | B2 | $\overline{\text{RSTN}}$ | Hardware Reset, Active-Low Input. The device remains in reset while this pin is in its active state. When the pin transitions to its inactive state, the device performs a POR reset (resetting all logic on all supplies except for real-time clock circuitry) and begins execution. This pin has an internal 25k Ω pullup to the V _{RTC} supply. This pin should be left unconnected if the system design does not provide a reset signal to the device. |
| 23 | B1 | $\overline{\text{SRSTN}}$ | Software Reset, Active-Low Input/Output. The device remains in software reset while this pin is in its active state. When the pin transitions to its inactive state, the device performs a reset to the ARM core, digital registers and peripherals (resetting most of the core logic on the V _{DD12} supply). This reset does not affect the POR only registers, RTC logic, ARM debug engine or JTAG debugger allowing for a soft reset without having to reconfiguring all registers. After the device senses $\overline{\text{SRSTN}}$ as a logic 0, the pin automatically reconfigures as an output sourcing a logic 0. The device continues to output for 6 system clock cycles and then repeats the input sensing/output driving until $\overline{\text{SRSTN}}$ is sensed inactive. This pin is internally connected with an internal 25k Ω pullup to the V _{RTC} supply. This pin should be left unconnected if the system design does not provide a reset signal to the device. |
| GENERAL-PURPOSE I/O AND SPECIAL FUNCTIONS | | | |
| 21 | C2 | P0.0 | General-Purpose I/O, Port 0. Most port pins have multiple special functions. See Table 1 for details. |
| 20 | C1 | P0.1 | |
| 19 | D4 | P0.2 | |
| 18 | D3 | P0.3 | |
| 17 | D1 | P0.4 | |
| 16 | D2 | P0.5 | |
| 15 | E3 | P0.6 | |
| 14 | E2 | P0.7 | |
| 12 | E1 | P1.0 | General-Purpose I/O, Port 1. Most port pins have multiple special functions. See Table 1 for details. |
| 11 | E4 | P1.1 | |
| 10 | F3 | P1.2 | |
| 9 | F2 | P1.3 | |
| 6 | F4 | P1.4 | |
| 5 | E5 | P1.5 | |
| 4 | G2 | P1.6 | |
| 99 | G3 | P1.7 | |

Pin Description (continued)

| PIN | | NAME | FUNCTION |
|------|-----|------|---|
| TQFP | WLP | | |
| 97 | J2 | P2.0 | General-Purpose I/O, Port 2. Most port pins have multiple special functions. See Table 1 for details. |
| 96 | H2 | P2.1 | |
| 95 | H3 | P2.2 | |
| 94 | J3 | P2.3 | |
| 93 | G4 | P2.4 | |
| 92 | H4 | P2.5 | |
| 89 | G5 | P2.6 | |
| 88 | H5 | P2.7 | |
| 86 | F5 | P3.0 | General-Purpose I/O, Port 3. Most port pins have multiple special functions. See Table 1 for details. |
| 85 | E6 | P3.1 | |
| 84 | H6 | P3.2 | |
| 83 | J6 | P3.3 | |
| 82 | G6 | P3.4 | |
| 81 | F6 | P3.5 | |
| 80 | J7 | P3.6 | |
| 79 | F7 | P3.7 | |
| 74 | J8 | P4.0 | General-Purpose I/O, Port 4. Most port pins have multiple special functions. See Table 1 for details. |
| 73 | H7 | P4.1 | |
| 72 | H9 | P4.2 | |
| 71 | H8 | P4.3 | |
| 70 | G7 | P4.4 | |
| 69 | G9 | P4.5 | |
| 68 | G8 | P4.6 | |
| 67 | F9 | P4.7 | |
| 49 | D7 | P5.0 | General-Purpose I/O, Port 5. Most port pins have multiple special functions. See Table 1 for details. |
| 48 | E7 | P5.1 | |
| 47 | C7 | P5.2 | |
| 45 | D6 | P5.3 | |
| 44 | C6 | P5.4 | |
| 30 | C5 | P5.5 | |
| 28 | D5 | P5.6 | |
| 27 | C4 | P5.7 | |
| 24 | C3 | P6.0 | General-Purpose I/O, Port 6.0. Most port pins have multiple special functions. See Table 1 for details. |

Pin Description (continued)

| PIN | | NAME | FUNCTION |
|--|-------------------|------|---------------------------------|
| TQFP | WLP | | |
| ANALOG INPUT PINS | | | |
| 35 | A4 | AIN0 | ADC Input 0. 5V-tolerant input. |
| 37 | A5 | AIN1 | ADC Input 1. 5V-tolerant input. |
| 39 | A6 | AIN2 | ADC Input 2 |
| 41 | A7 | AIN3 | ADC Input 3 |
| NO CONNECTS | | | |
| 1, 13, 25, 26, 32, 43, 50–54, 57, 66, 75–78, 87, 98, 100 | A1, A9, J1, J9 | N.C. | No Connection |

Table 1. MAX326320/MAX32621 GPIO Special Function Cross Reference

| GPIO | SPECIAL FUNCTIONS | | | | | | |
|------|----------------------|------------|------------|--------------|--------------|--|--|
| P0.0 | UART0A_RX | UART0B_TX | PT_PT0 | TIMER_TMR0 | GPIO_INT(P0) | | |
| P0.1 | UART0A_TX | UART0B_RX | PT_PT1 | TIMER_TMR1 | GPIO_INT(P0) | | |
| P0.2 | UART0A_CTS | UART0B_RTS | PT_PT2 | TIMER_TMR2 | GPIO_INT(P0) | | |
| P0.3 | UART0A_RTS | UART0B_CTS | PT_PT3 | TIMER_TMR3 | GPIO_INT(P0) | | |
| P0.4 | SPIM0_SCK | PT_PT4 | TIMER_TMR4 | GPIO_INT(P0) | | | |
| P0.5 | SPIM0_MOSI/ SDIO0 | PT_PT5 | TIMER_TMR5 | GPIO_INT(P0) | | | |
| P0.6 | SPIM0_MISO/ SDIO1 | PT_PT6 | TIMER_TMR0 | GPIO_INT(P0) | | | |
| P0.7 | SPIM0_SS0 | PT_PT7 | TIMER_TMR1 | GPIO_INT(P0) | | | |
| P1.0 | SPIM1_SCK | SPIX_SCK | PT_PT8 | TIMER_TMR2 | GPIO_INT(P1) | | |
| P1.1 | SPIM1_MOSI/ SDIO0 | SPIX_SDIO0 | PT_PT9 | TIMER_TMR3 | GPIO_INT(P1) | | |
| P1.2 | SPIM1_MISO/ SDIO1 | SPIX_SDIO1 | PT_PT10 | TIMER_TMR4 | GPIO_INT(P1) | | |
| P1.3 | SPIM1_SS0 | SPIX_SS | PT_PT11 | TIMER_TMR5 | GPIO_INT(P1) | | |
| P1.4 | SPIM1_SDIO2 | SPIX_SDIO2 | PT_PT12 | TIMER_TMR0 | GPIO_INT(P1) | | |
| P1.5 | SPIM1_SDIO3 | SPIX_SDIO3 | PT_PT13 | TIMER_TMR1 | GPIO_INT(P1) | | |
| P1.6 | I2CM0/SA_SDA | PT_PT14 | TIMER_TMR2 | GPIO_INT(P1) | | | |
| P1.7 | I2CM0/SA_SCL | PT_PT15 | TIMER_TMR3 | GPIO_INT(P1) | | | |
| P2.0 | UART1A_RX | UART1B_TX | PT_PT0 | TIMER_TMR4 | GPIO_INT(P2) | | |
| P2.1 | UART1A_TX | UART1B_RX | PT_PT1 | TIMER_TMR5 | GPIO_INT(P2) | | |

Table 1. MAX326320/MAX32621 GPIO Special Function Cross Reference (continued)

| GPIO | SPECIAL FUNCTIONS | | | | | | |
|------|-----------------------|-----------------------|------------|--------------|--------------|------------|--------------|
| | | | | | | | |
| P2.2 | UART1A_CTS | UART1B_RTS | PT_PT2 | TIMER_TMR0 | GPIO_INT(P2) | | |
| P2.3 | UART1A_RTS | UART1B_CTS | PT_PT3 | TIMER_TMR1 | GPIO_INT(P2) | | |
| P2.4 | SPIM2A_SCK | PT_PT4 | TIMER_TMR2 | GPIO_INT(P2) | | | |
| P2.5 | SPIM2A_MOSI/ SDIO0 | PT_PT5 | TIMER_TMR3 | GPIO_INT(P2) | | | |
| P2.6 | SPIM2A_MISO/ SDIO1 | PT_PT6 | TIMER_TMR4 | GPIO_INT(P2) | | | |
| P2.7 | SPIM2A_SS0 | PT_PT7 | TIMER_TMR5 | GPIO_INT(P2) | | | |
| P3.0 | UART2A_RX | UART2B_TX | PT_PT8 | TIMER_TMR0 | GPIO_INT(P3) | | |
| P3.1 | UART2A_TX | UART2B_RX | PT_PT9 | TIMER_TMR1 | GPIO_INT(P3) | | |
| P3.2 | UART2A_CTS | UART2B_RTS | PT_PT10 | TIMER_TMR2 | GPIO_INT(P3) | | |
| P3.3 | UART2A_RTS | UART2B_CTS | PT_PT11 | TIMER_TMR3 | GPIO_INT(P3) | | |
| P3.4 | I2CM1/SB_SDA | SPIM2A_SS1 | PT_PT12 | TIMER_TMR4 | GPIO_INT(P3) | | |
| P3.5 | I2CM1/SB_SCL | SPIM2A_SS2 | PT_PT13 | TIMER_TMR5 | GPIO_INT(P3) | | |
| P3.6 | SPIM1_SS1 | SPIX_SS1 | PT_PT14 | TIMER_TMR0 | GPIO_INT(P3) | | |
| P3.7 | SPIM1_SS2 | SPIX_SS2 | PT_PT15 | TIMER_TMR1 | GPIO_INT(P3) | | |
| P4.0 | OWM_I/O | SPIM2A_SR0 | PT_PT0 | TIMER_TMR2 | GPIO_INT(P4) | | |
| P4.1 | OWM_PUPEN | SPIM2A_SR1 | PT_PT1 | TIMER_TMR3 | GPIO_INT(P4) | | |
| P4.2 | SPIM0_SDIO2 | PT_PT2 | TIMER_TMR4 | GPIO_INT(P4) | | | |
| P4.3 | SPIM0_SDIO3 | PT_PT3 | TIMER_TMR5 | GPIO_INT(P4) | | | |
| P4.4 | SPIM0_SS1 | PT_PT4 | TIMER_TMR0 | GPIO_INT(P4) | | | |
| P4.5 | SPIM0_SS2 | PT_PT5 | TIMER_TMR1 | GPIO_INT(P4) | | | |
| P4.6 | SPIM0_SS3 | PT_PT6 | TIMER_TMR2 | GPIO_INT(P4) | | | |
| P4.7 | SPIM0_SS4 | PT_PT7 | TIMER_TMR3 | GPIO_INT(P4) | | | |
| P5.0 | SPIB_SCK | SPIM2B_SCK | PT_PT8 | TIMER_TMR4 | GPIO_INT(P5) | | |
| P5.1 | SPIB_SDIO0 | SPIM2B_ MOSI/SDIO0 | PT_PT9 | TIMER_TMR5 | GPIO_INT(P5) | | |
| P5.2 | SPIB_SDIO1 | SPIM2B_ MISO/SDIO1 | PT_PT10 | TIMER_TMR0 | GPIO_INT(P5) | | |
| P5.3 | SPIB_SSN0 | SPIM2B_SS0 | UART3A_RX | UART3B_TX | PT_PT11 | TIMER_TMR1 | GPIO_INT(P5) |
| P5.4 | SPIB_SDIO2 | SPIM2B_ SDIO2 | UART3A_TX | UART3B_RX | PT_PT12 | TIMER_TMR2 | GPIO_INT(P5) |
| P5.5 | SPIB_SDIO3 | SPIM2B_ SDIO3 | UART3A_CTS | UART3B_RTS | PT_PT13 | TIMER_TMR3 | GPIO_INT(P5) |
| P5.6 | SPIB_SRN | SPIM2B_SR | UART3A_RTS | UART3B_CTS | PT_PT14 | TIMER_TMR4 | GPIO_INT(P5) |
| P5.7 | I2CM2/SC_SDA | SPIM2B_SS1 | PT_PT15 | TIMER_TMR5 | GPIO_INT(P5) | | |
| P6.0 | I2CM2/SC_SCL | SPIM2B_SS2 | PT_PT0 | TIMER_TMR0 | GPIO_INT(P5) | | |

MAX32620/MAX32621

Detailed Description

The MAX32620/MAX32621 is a low-power, mixed signal microcontroller based on the ARM Cortex-M4F 32-bit core with a maximum operating frequency of 96MHz. The MAX32621 is a secure version, incorporating a trust protection unit (TPU) with encryption and advanced security features.

Application code executes from an onboard 2MB program flash memory, with 256KB SRAM available for general application use. An 8KB instruction cache improves execution throughput, and a transparent code scrambling scheme protects customer intellectual property residing in the program flash memory. Additionally, a SPI execute in place (XIP) external memory interface allows application code and data (up to 16MB) to be accessed from an external SPI memory device.

A 10-bit sigma-delta ADC is provided with a multiplexer front end for four external input channels (two of which are 5.5V tolerant) and six internal channels. Dedicated divided supply input channels allows direct monitoring of onboard power supplies V_{DD12} , V_{DD18} , V_{DDB} and V_{RTC} by the ADC. Built-in limit monitors allow converted input samples to be compared against user-configurable high and low limits, with an option to trigger an interrupt and wake the CPU from a low power mode if attention is required.

A wide variety of communications and interface peripherals are provided, including a USB 2.0-compliant slave interface, three master SPI interfaces, four UART interfaces with multidrop support, three master I²C interfaces, and a slave I²C interface.

ARM Cortex-M4F Architecture

The ARM Cortex-M4F processor is ideal for the emerging category of wearable medical and wellness applications. The architecture combines high-efficiency signal processing functionality with low power, low cost, and ease of use.

- Floating Point Unit (FPU)
- Memory Protection Unit
- Full debug support level
 - Debug Access Port (DAP)
 - Breakpoints
 - DWT
 - Flash patch
 - Halting debug
- Debug access port : JTAG or serial wire
- NVIC support

- 52 interrupts to be grouped by firmware into 8 levels of priority
- Cortex-M4F DSP supports Single Instruction Multiple Data (SIMD) Path DSP extensions, providing:
 - 4 parallel 8 bit add/sub
 - 2 parallel 16 bit add/sub
 - 2 parallel MACs
 - 32 or 64 bit accumulate
 - Signed, unsigned, data with or without saturation

Analog to Digital Converter (ADC)

The 10-bit sigma-delta ADC provides 4 external inputs and can also be configured to measure all internal power supplies. It operates at a maximum of 7.8ksps. AIN0 and AIN1 are 5.5V tolerant, making them suitable for monitoring batteries.

An optional feature allows samples captured by the ADC to be automatically compared against user-programmable high and low limits. Up to four channel limit pairs can be configured in this way. The comparison allows the ADC to trigger an interrupt (and potentially wake the CPU from a low power sleep mode) when a captured sample goes outside the preprogrammed limit range. Since this comparison is performed directly by the sample limit monitors, it can be performed even while the main CPU is suspended in a low-power mode.

The ADC reference is selectable:

- Internal bandgap
- External reference

Pulse Train Engine

Sixteen independent pulse train generators provide either a square wave or a repeating pattern from 2 bits to 32 bits in length. The frequency of each enabled pulse train generator is also set separately, based on a divide down (divide by 2, divide by 4, divide by 8, etc.) of the input pulse train module clock.

Any single pulse train generator or any desired group of pulse train generators can be restarted at the beginning of their patterns and synchronized with one another ensuring simultaneous startup. Additionally, each pulse train can operate in a single shot mode.

Clocking Scheme

The high-frequency internal relaxation oscillator operates at a nominal frequency of 96MHz. It is the primary clock source for the digital logic and peripherals.

An external 32.766kHz timebase is required when using the RTC or USB features of the device. The time base can be generated by attaching a 32kHz crystal. An external clock source can also be applied to the 32KIN pin. The external clock source must meet the electrical/timing requirements in the EC table. The 32kHz output can be directed out to pin P1.7 for observation and use.

Interrupt Sources

The ARM nested vector interrupt controller (NVIC) provides high speed, deterministic interrupt response, interrupt masking, and multiple interrupt sources. Each peripheral is connected to the NVIC and can have multiple interrupt flags to indicate the specific source of the interrupt within the peripheral. 52 interrupts can be grouped by firmware into 8 levels of priority (including internal and external interrupts).

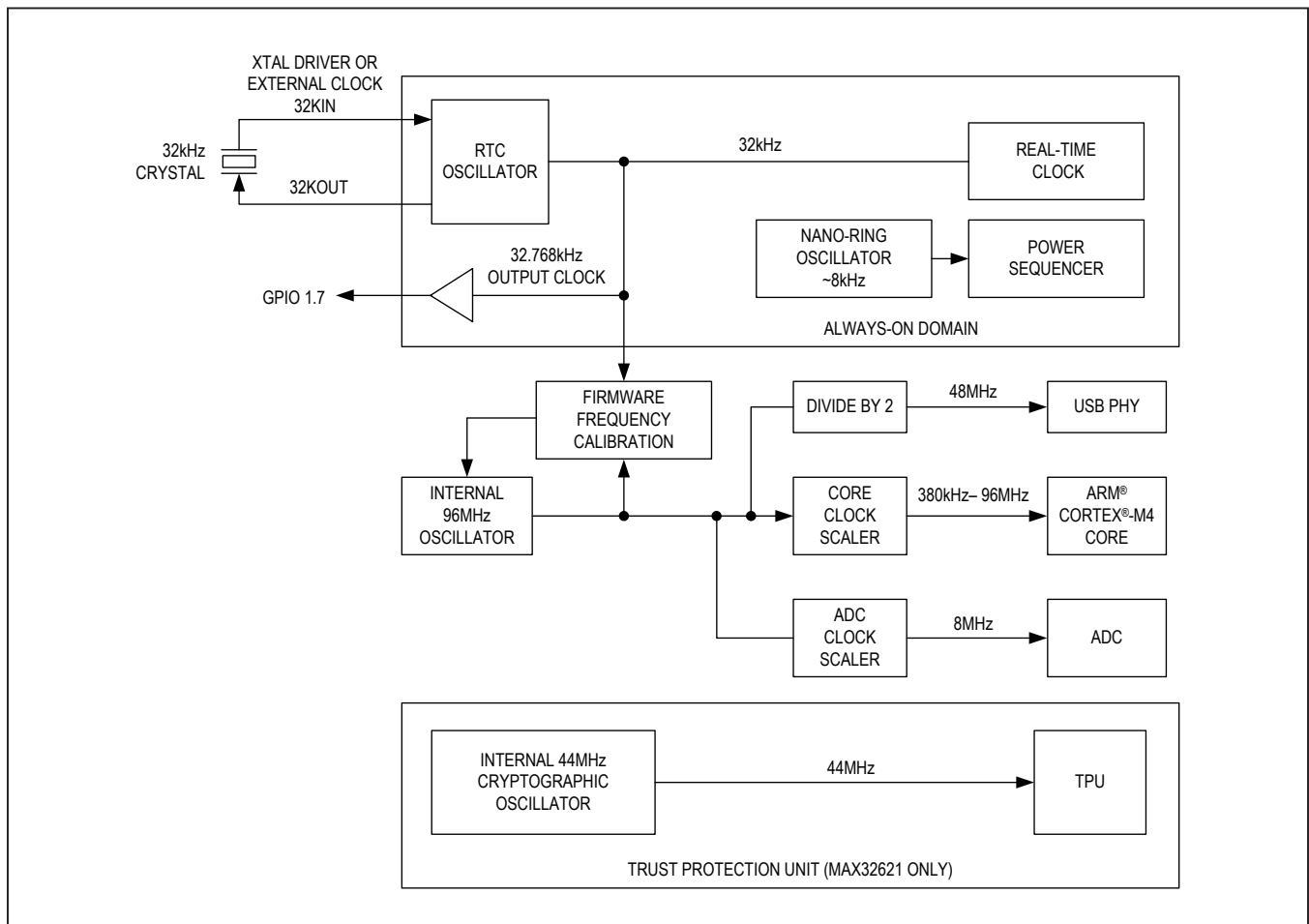

Figure 1. Clock Diagram

Real-Time Clock

A real-time clock (RTC) keeps the time of day in absolute seconds. The 32-bit seconds register can count up to approximately 136 years and be translated to calendar format by application software. A time-of-day alarm and independent subsecond alarm can cause an interrupt or wake the device from stop mode.

The minimum wake-up interval is 244 μ s.

CRC Module

The CRC hardware module provides fast calculations and data integrity checks by application software. The CRC module supports both the CRC-16-CCITT and CRC-32 ($X^{32} + X^{26} + X^{23} + X^{22} + X^{16} + X^{12} + X^{11} + X^{10} + X^8 + X^7 + X^5 + X^4 + X^2 + X^1 + 1$) polynomials.

Watchdog Timers

Two independent watchdog timers (WDT) with window support are provided. The WDT has multiple clock source options to ensure system security. It uses a 32-bit timer with prescaler to generate the watchdog reset. When enabled, the WDT must be reset prior to timeout or within a window of time if window mode is enabled. Failure to reset the WDT during the programmed timing window results in a watchdog timeout. WDT resets can cause firmware or power-on resets. The WDT1 or WDT2 flags

are set on reset if a watchdog expiration caused the system reset. The clock source options for the WDT include:

- Scaled-system clock
- RTC clock
- Nano-ring management clock

Programmable Timers

Six 32-bit timers provide timing, capture/compare, or generation of pulse-width modulated (PWM) signals. Each timer can be split into 2 16-bit timers, enabling 12 standard 16-bit timers.

32-bit timer features:

- 32-bit up/down auto-reload
- Programmable 16-bit prescaler
- PWM output generation
- Capture, compare, and capture/compare capability
- GPIOs can be assigned as external timer inputs, clock gating or capture, limited to an input frequency of 1/4 of the peripheral clock frequency
- Timer output pin
- Configurable as 2x 16-bit general purpose timers
- Timer interrupt

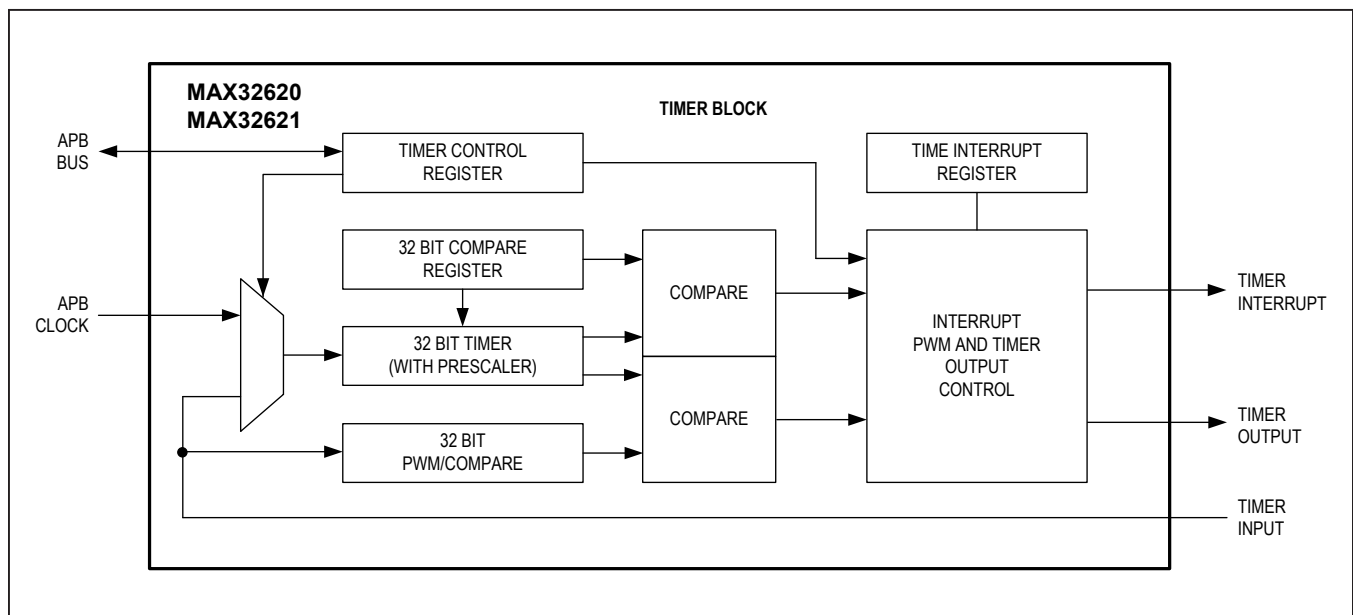

Figure 2. Timer Block Diagram, 32-Bit Mode

Serial Peripherals

USB Controller

The integrated USB controller is compliant with the full-speed (12Mb/s) USB 2.0 specification. The integrated USB physical interface (PHY) reduces board space and system cost. An integrated voltage regulator allows for smart switching between the main supply and V_{DDB} when connected to a USB host controller.

The USB controller supports DMA for the endpoint buffers. A total of 7 endpoint buffers are supported with configurable selection of IN or OUT in addition to endpoint 0.

An external 32kHz crystal or clock source is required for USB operation, even if the RTC function is not used. Although the USB timing is derived from the internal 96MHz oscillator, the default accuracy is not sufficient for USB operation. Firmware trimming of the 96MHz oscillator, using the 32kHz timebase as a reference, is necessary to comply with USB timing requirements.

I²C Master and Slave Ports

The I²C interface is a bidirectional, 2-wire serial bus that provides a medium-speed communications network. It can operate as a one-to-one, one-to-many or many-to-many communications medium. Three I²C master engines and one I²C-selectable slave engine interface to a wide variety of I²C-compatible peripherals. These engines support both standard mode and fast mode I²C standards. The slave engine shares the same I/O port as the master engines and is selectable through the I/O configuration settings. It provides the following features:

- Master or slave mode operation
- Information transfer over a serial data circuit (SDA) and serial clock circuit (SCL)
- Supports standard (7-bit) addressing
- Support for clock stretching to allow slower slave devices to operate on higher speed busses
- Multiple transfer rates:
 - Standard mode: 100kbps
 - Fast mode: 400kbps
- On-chip filter to reject spikes on the data circuit
- Receiver FIFO depth of 16 bytes
- Transmitter FIFO depth of 16 bytes

Serial Peripheral Interface Master Interface

The SPI master-mode-only interface operates independently in a single or multiple slave system and is fully accessible to the user application.

The SPI ports provide a highly configurable, flexible and efficient interface to communicate with a wide variety of SPI slave devices. The three SPI master ports (SPI0, SPI1, SPI2) support the following features:

- Supports all four SPI modes (0,1,2,3) for single-bit communication
- 3 or 4 wire mode for single-bit slave device communication
- Full-duplex operation in single-bit, 4-wire mode
- Dual and quad I/O supported
- Up to 5 slave select lines per port
- Up to 2 slave ready lines
- Programmable interface timing
- Programmable SCK frequency and duty cycle
- Programmable SCK alternate timing
- SS (slave select) assertion and deassertion timing with respect to leading/trailing SCK edge

Serial Peripheral Interface Execute in Place (XIP) Master

The SPI execute in place (XIP) master allows the CPU to transparently execute instructions stored in an external SPI flash. Instructions fetched through the SPI XIP master are cached just like instructions fetched from internal program memory. The SPI XIP master can also be used to access large amounts of external static data that would otherwise reside in internal data memory.

UART

All four universal asynchronous receiver-transmitter (UART) interfaces support full-duplex asynchronous communication with optional hardware flow control (HFC) modes to prevent data overruns. If HFC mode is enabled on a given port, the system uses two extra pins to implement the industry-standard request to send (RTS) and clear to send (CTS) methodology. Each UART is individually programmable.

- 2-wire interface or 4-wire interface with flow control
- 2x 32-byte send/receive FIFOs, one for transmit and receive
- Full-duplex operation for asynchronous data transfers
- Programmable interrupt for receive and transmit
- Independent baud-rate generator
- Programmable 9th bit parity support
- Start/stop bit support
- Hardware flow control using RTS/CTS
- Maximum baud rate 460.8kB

Trust Protection Unit (TPU) (MAX32621 Only)

The TPU enhances cryptographic data security for valuable intellectual property (IP) and data. A high-speed, dedicated, hardware-based math accelerator (MAA) performs mathematical computations that support strong cryptographic algorithms including:

- AES-128
- AES-192
- AES-256
- 1024-bit DSA
- 2048-bit (CRT)

The device provides a pseudo-random number generator which can be used to create cryptographic keys for any application. A user-selectable entropy source further increases the randomness and key strength.

The secure bootloader protects against unauthorized access to program memory.

Peripheral Management Unit (PMU)

The PMU is a DMA-based link list processing engine that performs operations and data transfers involving memory and/or peripherals in the advanced peripheral bus (APB) and advanced high-performance bus (AHB) peripheral memory space while the main CPU is in a sleep state. This allows low-overhead peripheral operations to be performed without the CPU, significantly reducing overall power consumption. Using the PMU with the CPU in a sleep state provides a lower-noise environment critical for obtaining optimum ADC performance.

Key features of the PMU engine include:

- Six independent channels with round-robin scheduling allows for multiple parallel operations
- Programmed using SRAM-based PMU opcodes
- PMU action can be initiated from interrupt conditions from peripherals without CPU
- Integrated AHB bus master
- Coprocessor-like state machine

Additional Documentation

Engineers must have the following documents to fully use this device:

- This data sheet, containing pin descriptions, feature overviews, and electrical specifications
- The device-appropriate user guide, containing detailed information and programming guidelines for core features and peripherals
- Errata sheets for specific revisions noting deviations from published specifications.

For information regarding these documents, visit Technical Support at support.maximintegrated.com/micro.

Development and Technical Support

Contact technical support for information about highly versatile, affordable development tools, available from Maxim Integrated and third-party vendors.

- Evaluation kits
- Software development kit
- Compilers
- Integrated development environments (IDEs)
- USB interface modules for programming and debugging

For technical support, go to support.maximintegrated.com/micro.

Additional Features

- ARM® Cortex®-M4F 32 Bit RISC CPU
 - Internal 96MHz Oscillator Saves Board Space and Cost
 - Memory Protection Unit
 - Floating Point Unit
- Ultra-Low Power
 - 95µA/MHz Dynamic Power Executing from Flash
 - 600nA (typ) Low Power Mode LP0 Current with RTC Enabled
 - 2.5µA Ultra-Low Power Data Retention Mode LP1 with Fast 5µs (typ) Wakeup
 - Dynamic Clock Disables Unused Peripherals/Logic
 - Wake Up from RTC, USB, GPIO, Multiple/Single Events
- Peripherals
 - 3x SPI Master Engines (1/2/4-bit Width)
 - 1x SPI Master XiP Engine for External Flash Execution
 - 3x I²C Master Engines (Fast/Standard Mode)
 - 1x I²C Slave Engine (Shared Pins with Master Engines)
 - 4x UART with Optional Hardware Flow Control
 - 1x 1-Wire Master
 - 16x Pulse Train Engines
 - USB 2.0-Compliant Peripheral, Full Speed (12Mb/s)
 - 6x 32-Bit Timers (Reconfigurable as 12 x 16-Bit Timers)
 - 32 Bit Real-Time Clock (RTC) with Time of Day Alarm
 - Supports 1149.1 JTAG with Serial Wire Debug
- Memory
 - 2MB Flash Memory
 - 8KB Instruction Cache
 - 256KB SRAM
- Supply Voltage
 - 1.2V ±5% Core Supply Voltage
 - 1.8V ±5% I/O and Analog Supply Voltage
 - Optional 3.3V ±5% USB Supply Voltage
- Other Features:
 - 49 General Purpose I/O (GPIO)
 - 2x Programmable Watchdog Timers with Independent Clock Sources
- Analog Components
 - Four-Input, 10-Bit Sigma-Delta ADC Operating at 7.8 kS/s
 - 5.5V, 1.2V-Tolerant Inputs
 - Internal or External Reference
- Peripheral Management Unit (PMU) Reduces Power Consumption in Sleep Mode
- Trust Protection Unit for Data Integrity and IP Protection
 - AES Hardware Engine
 - MAA for ECDSA and Modular Arithmetic
 - Trust Protection Unit (TPU) for End-to-End Security
 - Hardware PRNG Entropy Generator
 - Secure Boot Loader
 - CRC16/32 Engine
 - Factory-Programmed Unique ID

Typical Application Circuit—Electrocardiogram (ECG) Patch

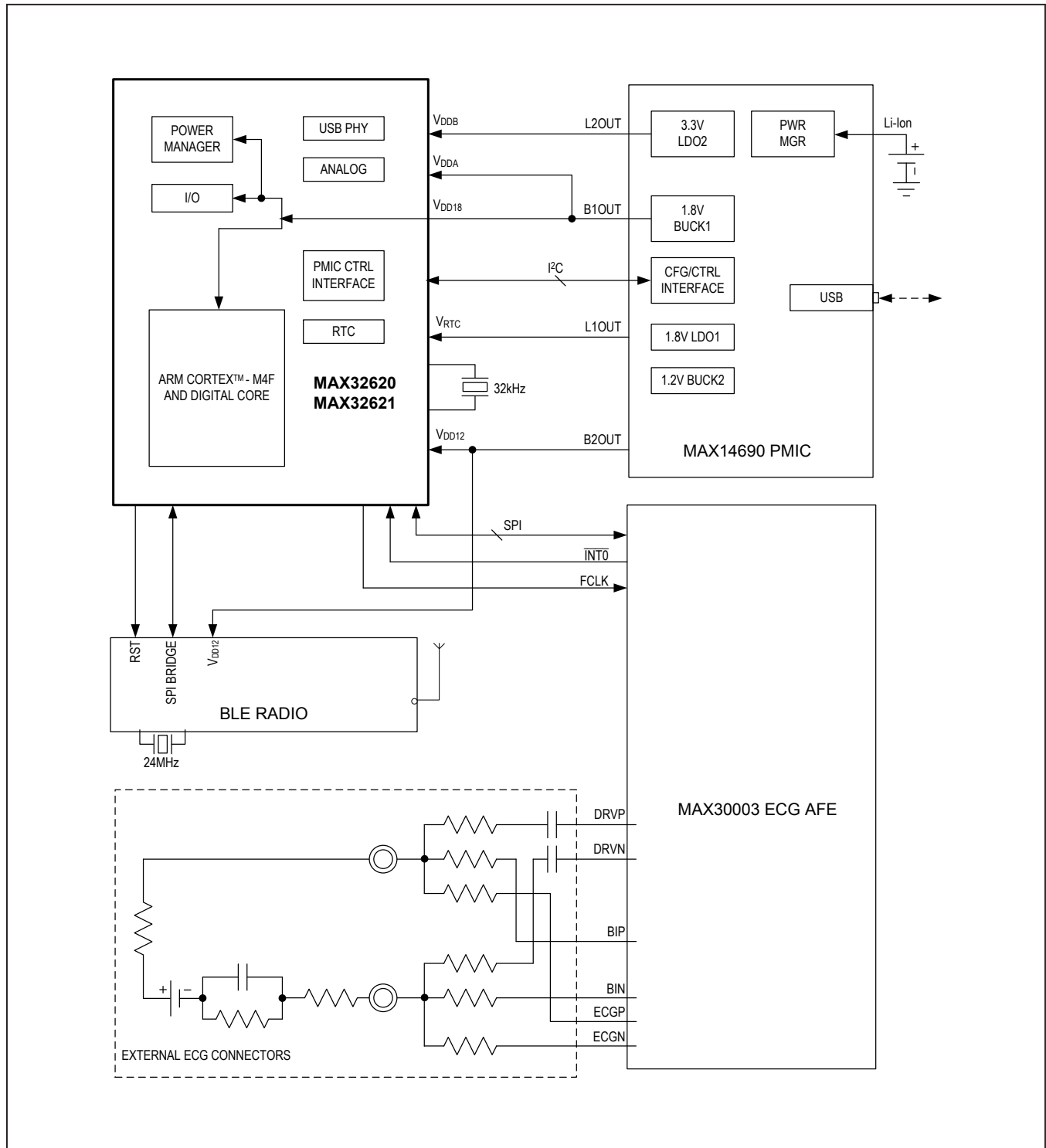

Ordering Information

| PART | FLASH (MB) | SRAM (KB) | TRUST PROTECTION UNIT | PIN-PACKAGE |
|---------------|------------|-----------|-----------------------|-------------|
| MAX32620ICQ+ | 2 | 256 | No | 100 TQFP |
| MAX32620IWG+ | 2 | 256 | No | 81 WLP |
| MAX32620IWG+T | 2 | 256 | No | 81 WLP |
| MAX32621ICQ+ | 2 | 256 | Yes | 100 TQFP |
| MAX32621IWG+ | 2 | 256 | Yes | 81 WLP |
| MAX32621IWG+T | 2 | 256 | Yes | 81 WLP |

+Denotes a lead(Pb)-free/RoHS-compliant package.

T = Tape and reel.

Package Information

For the latest package outline information and land patterns (footprints), go to www.maximintegrated.com/packages. Note that a "+", "#", or "-" in the package code indicates RoHS status only. Package drawings may show a different suffix character, but the drawing pertains to the package regardless of RoHS status.

| PACKAGE TYPE | PACKAGE CODE | OUTLINE NO. | LAND PATTERN NO. |
|--------------|--------------|-------------------------|--|
| 81 WLP | W813D3+1 | 21-0776 | Refer to Application Note 1891 |
| 100 TQFP-EP | C100E+3 | 21-0116 | 90-0154 |

Revision History

| REVISION NUMBER | REVISION DATE | DESCRIPTION | PAGES CHANGED |
|-----------------|---------------|-----------------|---------------|
| 0 | 6/15 | Initial release | — |

For pricing, delivery, and ordering information, please contact Maxim Direct at 1-888-629-4642, or visit Maxim Integrated's website at www.maximintegrated.com.

Maxim Integrated cannot assume responsibility for use of any circuitry other than circuitry entirely embodied in a Maxim Integrated product. No circuit patent licenses are implied. Maxim Integrated reserves the right to change the circuitry and specifications without notice at any time. The parametric values (min and max limits) shown in the Electrical Characteristics table are guaranteed. Other parametric values quoted in this data sheet are provided for guidance.