

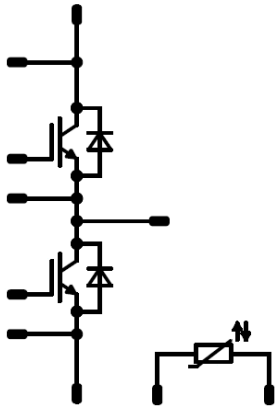

Vincotech

A0-VS122PA600M7-L759F70
A0-VP122PA600M7-L759T
 target datasheet

VINcoDUAL E3	1200 V / 600 A
<div style="border: 1px solid black; padding: 5px; margin-bottom: 5px;"> <p style="text-align: center; background-color: #cccccc; margin: 0;">Features</p> <ul style="list-style-type: none"> Low V_{CEsat} with the new 7th gen Mitsubishi chip generation Max Junction Temperature T_{vjmax} 175°C Solid cover technology for higher reliability Industry standard housing Press-fit pin and pre-applied Phase Change Thermal Interface Material available </div> <div style="border: 1px solid black; padding: 5px; margin-bottom: 5px;"> <p style="text-align: center; background-color: #cccccc; margin: 0;">Target applications</p> <ul style="list-style-type: none"> Industrial Drives Power Supply UPS </div> <div style="border: 1px solid black; padding: 5px;"> <p style="text-align: center; background-color: #cccccc; margin: 0;">Types</p> <ul style="list-style-type: none"> A0-VS122PA600M7-L759F70 A0-VP122PA600M7-L759F70T </div>	<div style="border: 1px solid black; padding: 5px; margin-bottom: 5px;"> <p style="text-align: center; background-color: #cccccc; margin: 0;">VINco E3</p>  </div> <div style="border: 1px solid black; padding: 5px;"> <p style="text-align: center; background-color: #cccccc; margin: 0;">Schematic</p>  </div>

Maximum Ratings

$T_j = 25\text{ °C}$, unless otherwise specified

Parameter	Symbol	Condition	Value	Unit
Half Bridge Switch				
Collector-emitter voltage	V_{CES}		1200	V
Collector current	I_c	$T_j = T_{jmax}$ $T_s = 80\text{ °C}$	559	A
Repetitive peak collector current	I_{CRM}	t_p limited by T_{jmax}	1200	A
Total power dissipation	P_{tot}	$T_j = T_{jmax}$ $T_s = 80\text{ °C}$	1092	W
Gate-emitter voltage	V_{GES}		±20	V
Maximum junction temperature	T_{jmax}		175	°C



Vincotech

A0-VS122PA600M7-L759F70
A0-VP122PA600M7-L759T
target datasheet

Maximum Ratings

$T_j = 25\text{ °C}$, unless otherwise specified

Parameter	Symbol	Condition	Value	Unit
Half Bridge Diode				
Peak repetitive reverse voltage	V_{RRM}		1200	V
Continuous (direct) forward current	I_F	$T_j = T_{jmax}$ $T_s = 80\text{ °C}$	486	A
Repetitive peak forward current	I_{FRM}		1200	A
Total power dissipation	P_{tot}	$T_j = T_{jmax}$ $T_s = 80\text{ °C}$	742	W
Maximum junction temperature	T_{jmax}		175	°C

Module Properties

Thermal Properties

Storage temperature	T_{stg}		-40...+125	°C
Operation temperature under switching condition	T_{jop}		-40...($T_{jmax} - 25$)	°C

Isolation Properties

Isolation voltage	V_{isol}	DC Test Voltage $t_p = 2\text{ s}$	4000	V
Creepage distance			18,1	mm
Clearance			16,2	mm
Comparative Tracking Index	CTI		> 200	



Characteristic Values

Parameter	Symbol	Conditions					Value			Unit
		V_{GS} [V]	V_{GE} [V]	V_{DS} [V]	I_C [A] I_D [A] I_F [A]	T_j [°C]	Min	Typ	Max	

Half Bridge Switch

Static

Gate-emitter threshold voltage	$V_{GE(th)}$	$V_{GE} = V_{CE}$			0,06	25	5,4	6	6,6	V
Collector-emitter saturation voltage	V_{CEsat}		15		600	25 125 150		1,70 1,95 2,00	2,15	V
Collector-emitter cut-off current	I_{CES}		0	1200		25			600	μA
Gate-emitter leakage current	I_{GES}		20	0		25			1500	nA
Internal gate resistance	r_g							0,67		Ω
Input capacitance	C_{ies}							111000		pF
Output capacitance	C_{oes}		0	10		25		3300		
Reverse transfer capacitance	C_{res}							1260		
Gate charge	Q_g		15	600	600	25		3600		nC

Thermal

Thermal resistance junction to case	$R_{th(j-c)}$							0,052		K/W
Thermal resistance case to sink	$R_{th(c-s)}$	phase-change material $\lambda = 3,4$ W/mK						0,035		K/W

Half Bridge Diode

Static

Forward voltage	V_F				600	25 125 150		1,70 1,70 1,70	2,2	V
Reverse leakage current	I_R			1200		25			360	μA

Thermal

Thermal resistance junction to case	$R_{th(j-c)}$							0,084		K/W
Thermal resistance case to sink	$R_{th(c-s)}$	phase-change material $\lambda = 3,4$ W/mK						0,044		K/W



Vincotech

A0-VS122PA600M7-L759F70
A0-VP122PA600M7-L759T
 target datasheet

Characteristic Values

Parameter	Symbol	Conditions					Value			Unit
		V_{GS} [V]	V_{GE} [V]	V_{DS} [V]	I_D [A]	T_j [°C]	Min	Typ	Max	

Thermistor

Rated resistance	R					25		5		kΩ
Deviation of R_{100}	$\Delta_{R/R}$	$R_{100} = 493 \Omega$				100	-5		+5	%
Power dissipation	P					25		245		mW
Power dissipation constant						25		1,4		mW/K
B-value	$B_{(25/50)}$	Tol. $\pm 2 \%$				25		3375		K
B-value	$B_{(25/100)}$	Tol. $\pm 2 \%$				25		3437		K
Vincotech NTC Reference									K	



A0-VS122PA600M7-L759F70
A0-VP122PA600M7-L759T
 target datasheet

Vincotech

Ordering Code & Marking							
Version			Ordering Code				
without thermal paste with solder pins			A0-VS122PA600M7-L759F70				
with thermal paste with solder pins			A0-VS122PA600M7-L759F70- /3/				
without thermal paste with Press-fit pins			A0-VP122PA600M7-L759F70T				
with thermal paste with Press-fit pins			A0-VP122PA600M7-L759F70T- /3/				
NN-NNNNNNNNNN-TTTTTIVV VIN WWYY LLLLL SSSS		Text	Name	VIN	Date code	Lot	Serial
			NN-NNNNNNNNNN-TTTTTIVV VIN WWYY LLLLL SSSS	VIN	WWYY	LLLLL	SSSS
			Type&Ver	Lot number	Serial	Date code	
		Datamatrix	TTTTTIVV	LLLLL	SSSS	WWYY	

Pin table [mm]			
Pin	X	Y	Function
1	7,24	-0,45	Therm1
2	11,06	-0,45	Therm2
3	60,58	-0,45	G12
4	64,4	-0,45	S12
5	87,26	-0,45	C12
6	-	-	Ph
7	-	-	Ph
8	37,72	57,95	G11
9	33,92	57,95	S11
10	-	-	DC-
11	-	-	DC+



Vincotech

A0-VS122PA600M7-L759F70
A0-VP122PA600M7-L759T
 target datasheet

Pinout

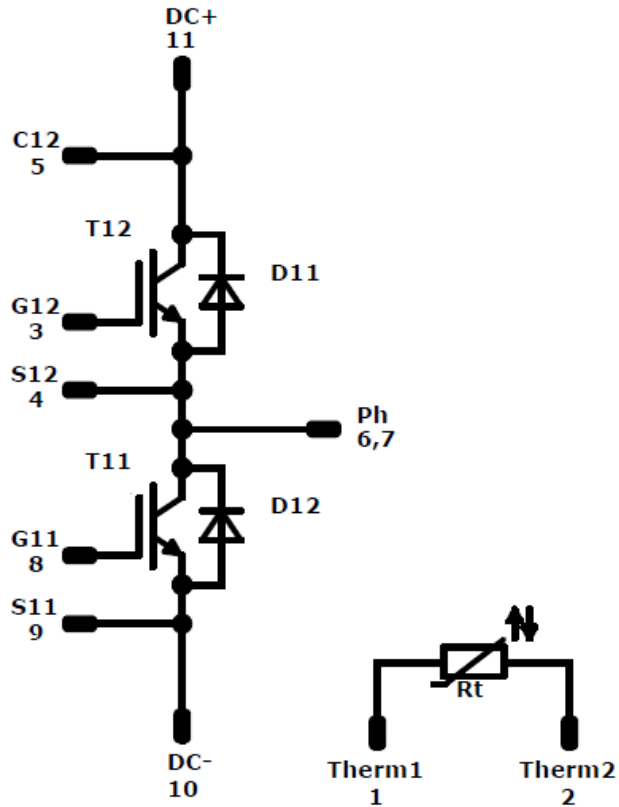

Identification

ID	Component	Voltage	Current	Function	Comment
T11,T12	IGBT	1200 V	600 A	Half Bridge Switch	
D11,D12	FWD	1200 V	600 A	Half Bridge Diode	
Rt	NTC			Thermistor	



Vincotech

A0-VS122PA600M7-L759F70
A0-VP122PA600M7-L759T
target datasheet

Packaging instruction			
Standard packaging quantity (SPQ)	24	>SPQ	Standard
		<SPQ	Sample

Document No.:	Date:	Modification:	Pages
A0-Vx122PA600M7-L759F70x-T1-14	28 Apr. 2016		

Product status definition		
Datasheet Status	Product Status	Definition
Target	Formative or In Design	This datasheet contains the design specifications for product development. Specifications may change in any manner without notice. The data contained is exclusively intended for technically trained staff.

DISCLAIMER

The information, specifications, procedures, methods and recommendations herein (together "information") are presented by Vincotech to reader in good faith, are believed to be accurate and reliable, but may well be incomplete and/or not applicable to all conditions or situations that may exist or occur. Vincotech reserves the right to make any changes without further notice to any products to improve reliability, function or design. No representation, guarantee or warranty is made to reader as to the accuracy, reliability or completeness of said information or that the application or use of any of the same will avoid hazards, accidents, losses, damages or injury of any kind to persons or property or that the same will not infringe third parties rights or give desired results. It is reader's sole responsibility to test and determine the suitability of the information and the product for reader's intended use.

LIFE SUPPORT POLICY

Vincotech products are not authorised for use as critical components in life support devices or systems without the express written approval of Vincotech.

As used herein:

1. Life support devices or systems are devices or systems which, (a) are intended for surgical implant into the body, or (b) support or sustain life, or (c) whose failure to perform when properly used in accordance with instructions for use provided in labelling can be reasonably expected to result in significant injury to the user.
2. A critical component is any component of a life support device or system whose failure to perform can be reasonably expected to cause the failure of the life support device or system, or to affect its safety or effectiveness.