

PMW3325DB-TWV1: Optical Gaming Navigation Chip

General Description

PMW3325DB-TWV1 is PixArt Imaging's optical gaming navigation chip suitable for wired & wireless gaming mouse application. It is packaged in an 8pin staggered dual-in-line package (DIP). It provides excellent gaming experience with the features of high speed & resolution to fulfill gamers' need. The chip comes with self-adjusting variable frame rate algorithm to enable wireless gaming application. It is designed to be used with LM31-LNG or LM33-LSG lens to achieve optimum performance.

Key Features

- Small form factor PDIP 8L molded lead-frame package
- Operating Voltage: 1.80V - 2.10V
- High speed motion detection 100ips (typical) and acceleration 20g (max).
- Selectable resolutions up to 5000cpi
- Three-wire serial port interface (SDIO)
- Internal oscillator — no clock input needed
- Self-adjusting variable frame rate for optimum power performance in wireless application
- Programmable rest modes for;
 - Corded gaming mode
 - Cordless gaming mode
- Customizable response time and downshift time for rest modes
- Angle snapping

Applications

- Wired Gaming Optical Mouse
- Wireless Gaming Optical Mouse
- Trackball application

Key Parameters

Parameter	Value
Supply Voltage (V)	VDD: 1.80 – 2.10V
Interface	3-wire Serial Peripheral Interface
Supply Current (Average) @ VDD = 2.0V <i>Note: includes LED current</i>	Run Avg.: 6.70mA Rest1: 1.60mA Rest2: 72uA Rest3: 56uA Power Down: 5uA
Resolution (cpi)	Up to 5000
Tracking Speed (ips)	100
Acceleration (g)	20
Package Type (mm)	8L PDIP

Ordering Information

Part Number	Package Type
PMW3325DB-TWV1	8-pin DIP Package
LM31-LNG	Trim Lens
LM33-LSG	Small Trim Lens

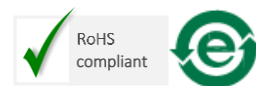

For any additional inquiries, please contact us at <http://www.pixart.com/contact.asp>

Contents

PMW3325DB-TWV1: Optical Gaming Navigation Chip 1

 General Description 1

 Key Features..... 1

 Applications..... 1

 Key Parameters 1

 Ordering Information 1

List of Figures 3

List of Tables 3

1.0 Introduction 4

 1.1 Overview 4

 1.2 Terminology 4

 1.3 Pins Description 5

2.0 Operating Specifications 6

 2.1 Absolute Maximum Ratings..... 6

 2.2 Recommended Operating Conditions 6

 2.3 Thermal Specifications 7

 2.4 DC Characteristics..... 7

 2.5 AC Characteristics..... 8

3.0 Mechanical Specifications 10

 3.1 Mechanical Dimension 10

 3.2 Package Marking 11

 3.3 Assembly Drawings..... 11

 3.4 Lens Outline Drawing 14

4.0 System Level Description 16

 4.1 Reference Application Schematic Diagram..... 16

 4.2 PCB Assembly Recommendation 17

5.0 Registers 18

 5.1 Registers List..... 18

Document Revision History 19

List of Figures

Figure 1. Functional Block Diagram 4

Figure 2. Pin Configuration 5

Figure 3 Mean Resolution vs. Z Height at resolution of 3000dpi 9

Figure 4. Package Drawing Outline 10

Figure 5. Recommended chip orientation, mechanical cutouts & spacing (Top View) 11

Figure 6. Distance from Lens Reference Plane to Surface 12

Figure 7. Exploded View of Mouse Assembly 12

Figure 8. 2D Assembly 13

Figure 9. LM31-LNG Trim Lens Outline Drawing 14

Figure 10. LM33-LSG Small Trim Lens Outline Drawings 15

Figure 11. PMW3325DB-TWV1 Reference Mouse Schematic..... 16

List of Tables

Table 1. PMW3325DB Pins Description 5

Table 2. Absolute Maximum Ratings 6

Table 3. Recommended Operating Conditions..... 6

Table 4. Thermal Specifications 7

Table 5. DC Electrical Specifications 7

Table 6. AC Electrical Specifications 8

Table 7. Package Dimensions 10

Table 8. Code Identification..... 11

Table 9. Register List..... 18

1.0 Introduction

1.1 Overview

PMW3325DB-TWV1 is based on Optical Navigation Technology, which measures changes in position by optically acquiring sequential surface images (frames) and mathematically determining the direction and magnitude of movement. PMW3325DB-TWV1 contains an Image Acquisition System (IAS), a Digital Signal Processor (DSP), and a three-wire serial port. The IAS acquires microscopic surface images via the lens and illumination system. These images are processed by the DSP to determine the direction and distance of motion. The DSP calculates the ΔX and ΔY relative displacement values. An external microcontroller reads and translates the ΔX and ΔY information from the chip serial port into PS2, USB, or RF signals before sending them to the host PC.

Note: Throughout this document PMW3325DB-TWV1 is referred to as the PMW3325DB.

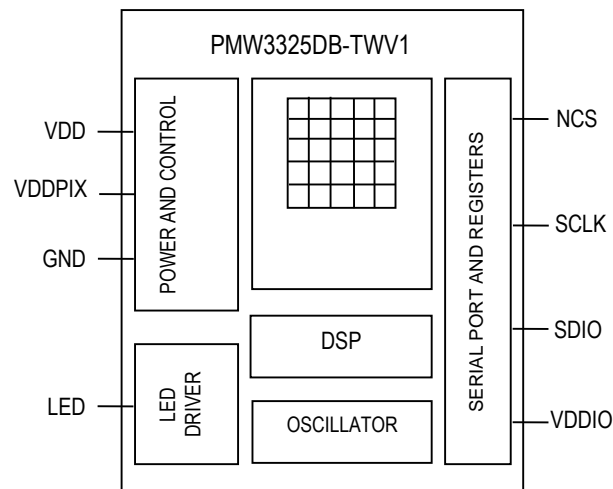

Figure 1. Functional Block Diagram

1.2 Terminology

Term	Description
DSP	Digital Signal Processing
LED	Light Emitting Diode
NCS	Chip Select
VDDPIX	Internal Regulator Output
VDD	Supply voltage
SCLK	Serial Clock
SDIO	Serial Data In & Out
SPI	Serial Peripheral Interface
GND	Ground

1.3 Pins Description

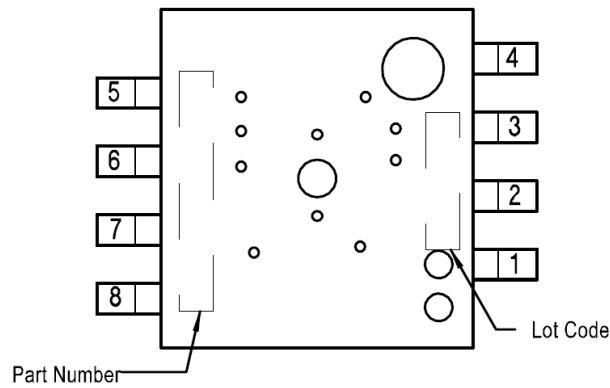

Figure 2. Pin Configuration

Table 1. PMW3325DB Pins Description

Pin No.	Name	Type	Description
1	LED	Input	LED Illumination Control input
2	VDDPIX	Power	Regulator output for selective analog circuit
3	VDD	Power	Power supply
4	SCLK	In	Serial clock input
5	VDDIO	Power	Interface signal voltage level
6	GND	Gnd	Ground
7	SDIO	Input/Output	Serial data in/out
8	NCS	Input	Chip select (active low)

2.0 Operating Specifications

2.1 Absolute Maximum Ratings

Stresses greater than those listed under “Absolute Maximum Ratings” may cause permanent damage to the device. These are the stress ratings only and functional operation of the device at these or any other condition beyond those indicated for extended period of time may affect device reliability.

Table 2. Absolute Maximum Ratings

Parameters	Symbol	Min.	Max.	Unit	Notes
Storage Temperature	T _S	-40	85	°C	
Lead Solder Temperature	T _{SOLDER}		260	°C	For 10 seconds, 1.6mm below seating plane
Supply Voltage	V _{DD}	-0.5	2.15	V	Including V _{NA} of 100 mV _{pp}
ESD	ESD _{HBM}		2	kV	All pins, Human Body Model MIL 883 Method 3015
Input Voltage	V _{IN}	-0.5	V _{DD} +0.5	V	All digital pins
Output Latch up Current	mA		200		All digital pins

Notes:

1. Stresses greater than those listed under “Absolute Maximum Ratings” may cause permanent damage to the device. These are the stress ratings only and functional operation of the device at these or any other condition beyond those indicated for extended period of time may affect device reliability.
2. The maximum ratings do not reflect eye-safe operation.
3. The inherent design of this component causes it to be sensitive to electrostatic discharge. The ESD threshold is listed above. To prevent ESD induced damage, take adequate ESD precautions when handling this product

2.2 Recommended Operating Conditions

Table 3. Recommended Operating Conditions

Description	Symbol	Min.	Typ.	Max.	Unit	Notes
Operating Temperature	T _A	0		40	°C	
Power Supply Voltage	V _{DD}	1.80	2.00	2.10	V	
Power Supply Rise Time	t _{RT}	0.15		20	ms	0 to V _{DD}
Supply Noise (Sinusoidal)	V _{NA}			100	mV _{p-p}	10kHz – 50MHz
Serial Port Clock Frequency	f _{SCLK}			2	MHz	Active drive, 50% duty cycle
Distance from Lens Reference Plane to Tracking Surface	Z	2.20	2.40	2.60	mm	Results in +/-0.2 mm minimum DOF.
Speed	S		100		ips	
Acceleration	A			20	g	In run mode
Load Capacitance	C _{out}			100	pF	SDIO and MOTION

Note: PixArt does not guarantee the chip performance if the operating temperature is beyond the specified limit.

2.3 Thermal Specifications

Table 4. Thermal Specifications

Parameters	Symbol	Min.	Typ.	Max.	Unit	Notes
Storage Temperature	T _S	-25	-	80	°C	
Lead-free Solder Temperature	T _P	-	-	260	°C	For 10 seconds, 1.6mm below seating plane for wave soldering

2.4 DC Characteristics

Table 5. DC Electrical Specifications

Parameters	Symbol	Min.	Typ.	Max.	Unit	Conditions
DC Supply Current in various modes	I _{DD_RUN} [VFR1+VFR2]		6.70		mA	I _{DD_RUN} [VFR1+VFR2] number is based on the assumption of; VFR1:VFR2 = 90%:10% MCU poll the motion registers at the 1ms interval
	I _{DD_RUN_VFR1} [3k FPS]		6.20		mA	
	I _{DD_RUN_VFR2} [4.6k FPS]		8.50		mA	
	I _{DD_REST1}		1.60		mA	
	I _{DD_REST2}		72		uA	
	I _{DD_REST3}		56		uA	
Power Down Current	I _{PD}		5		uA	
Input Low Voltage	V _{IL}			0.3* VDD	V	SCLK, SDIO, NCS
Input High Voltage	V _{IH}	0.7* VDD			V	SCLK, SDIO, NCS
Input Hysteresis	V _{I_HYS}		100		mV	SCLK, SDIO, NCS, VDDIO
Input Leakage Current	I _{LEAK}		± 1	± 10	uA	V _{in} =VDD-0.6V or 0V, SCLK, SDIO, NCS, VDDIO
Output Low Voltage	V _{OL}			0.45	V	I _{OUT} = 1mA, SDIO
Output Low Voltage, SDIO	V _{OH}	VDD-0.45			V	I _{OUT} = -1mA, SDIO
Input Capacitance	C _{in}		50		pF	SCLK, SDIO, NCS

Note: All the parameters are tested under recommended operating conditions. Typical values at 25 °C, V_{DD} = 2.0 V & LED current = 8mA

2.5 AC Characteristics

Table 6. AC Electrical Specifications

Parameters	Symbol	Min.	Typ.	Max.	Unit	Conditions
Motion Delay After Reset	$t_{MOT-RST}$	50			ms	From reset to valid motion, assuming motion is present
Shutdown	t_{STDWN}			500	μs	From Shutdown mode active to low current
Wake up from Shutdown	t_{WAKEUP}	50		60	ms	From Shutdown mode inactive to valid motion. Notes: A RESET must be asserted after a shutdown. Refer to section "Notes on Shutdown", also note $t_{MOT-RST}$.
SDIO Output Rise Time	t_{r-SDIO}		50		ns	$C_L = 100pF$
SDIO Output Fall Time	t_{f-SDIO}		50		ns	$C_L = 100pF$
SDIO Output Delay After SCLK	$t_{DLY-SDIO}$			90	ns	From SCLK falling edge to SDIO output data valid, no load condition
SDIO Output Hold Time	$t_{hold-SDIO}$	200			ns	Data held until next falling SCLK edge
SDIO input Hold Time	$t_{hold-SDIO\ input}$	200			ns	Amount of time data is valid after SCLK rising edge
SDIO input Setup Time	$t_{setup-SDIO\ input}$	120			ns	From data valid to SCLK rising edge
SPI Time Between Write Commands	t_{SWW}	45			μs	From rising SCLK for last bit of the first data byte, to rising SCLK for last bit of the second data byte.
SPI Time Between Write And Read Commands	t_{SWR}	45			μs	From rising SCLK for last bit of the 1st data byte, to rising SCLK for last bit of the second address byte
SPI Time Between Read And Subsequent Commands	t_{SRW} t_{SRR}	20			μs	From rising SCLK for last bit of the 1st data byte, to falling SCLK for the 1st bit of data being read.
SPI Read Address-Data Delay	t_{SRAD}	35			μs	From rising SCLK for last bit of the address byte, to falling SCLK for the 1st bit of data being read.
NCS Inactive After Motion Burst	t_{BEXIT}	500			ns	Minimum NCS inactive time after motion burst before next SPI usage
NCS To SCLK Active	$t_{NCS-SCLK}$	120			ns	From last NCS falling edge to 1st SCK rising edge.
SCLK To NCS Inactive SDIO Write	$t_{SCLK-NCS\ write}$	120			ns	From last SCLK falling edge to NCS rising edge, for valid SDIO data transfer

Parameters	Symbol	Min.	Typ.	Max.	Unit	Conditions
SCLK To NCS Inactive SDIO Read	$t_{\text{SCLK-NCS read}}$	35			μs	From last SCLK falling edge to NCS rising edge, for valid SDIO data transfer
NCS To SDIO High-Z	$t_{\text{NCS-SDIO}}$			500	ns	From NCS rising edge to SDIO high-Z state
Transient Supply Current	IDDT			60	mA	Max supply current during the supply ramp from 0V to V_{DD} with min 150us and max 20ms rise time. (Does not include charging currents of bypass capacitors)

Note: All the parameters are tested under recommended operating conditions. Typical values at 25 °C & VDD=2.0V

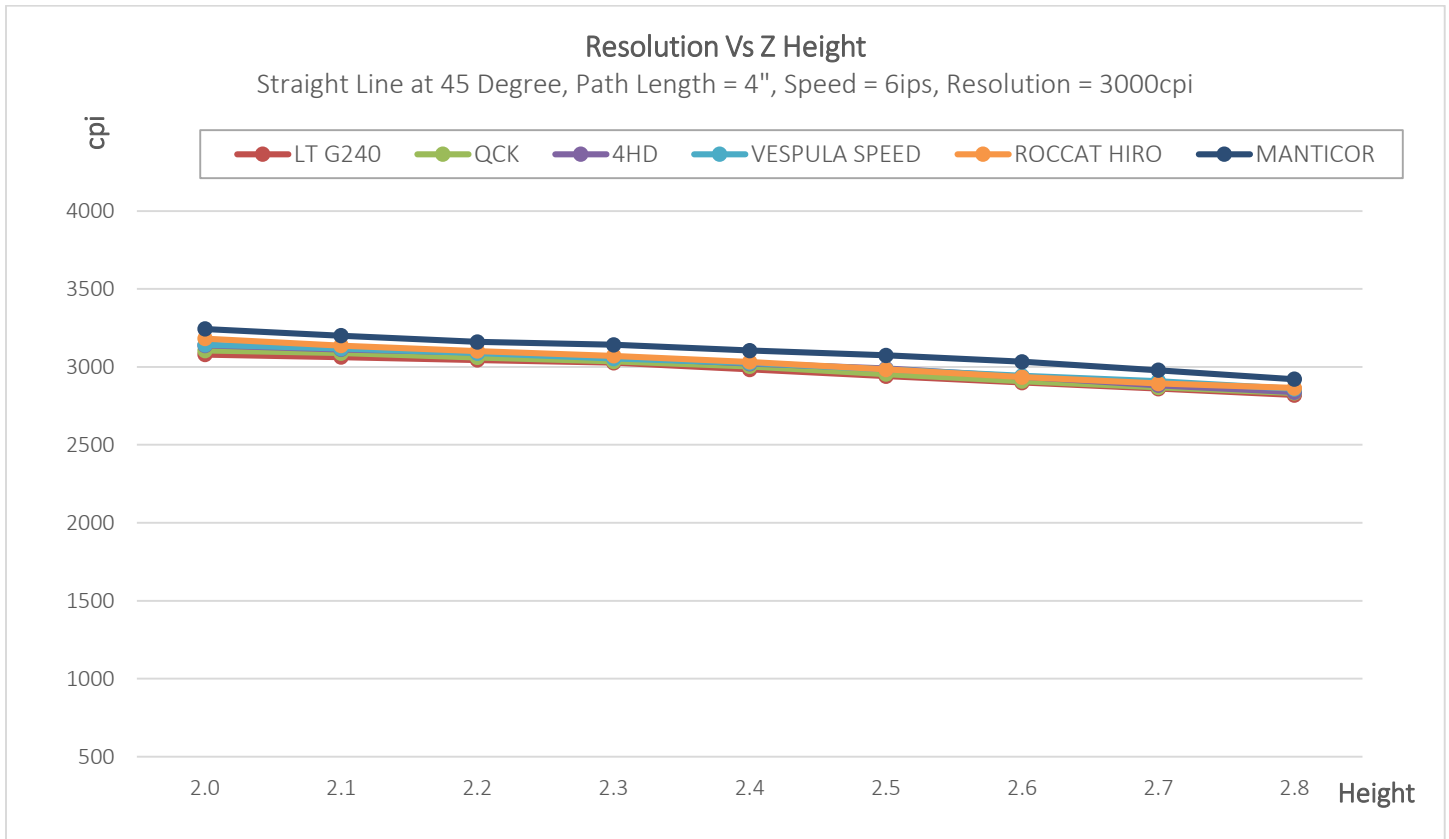

Figure 3 Mean Resolution vs. Z Height at resolution of 3000dpi

3.0 Mechanical Specifications

3.1 Mechanical Dimension

Table 7. Package Dimensions

Parameters	Nominal	Min.	Max.	Unit
Package Body Dimension X	9.90	9.80	10.00	mm
Package Body Dimension Y	9.10	9.00	9.20	mm
Package Width (inclusive pins)	12.85	12.35	13.35	mm
Lead Length	5.15	5.05	5.25	mm
Lead Pitch	2.00	1.85	2.15	mm
Total Lead Count	8	-	-	-
Lead Offset	1.00	-	-	mm
Lead Width	0.50	0.40	0.60	mm
Hole Diameter	0.70	0.65	0.75	mm
Center of Hole from edge of body X	4.55	4.45	4.65	mm
Center of Hole from edge of body Y	3.92	3.82	4.02	mm

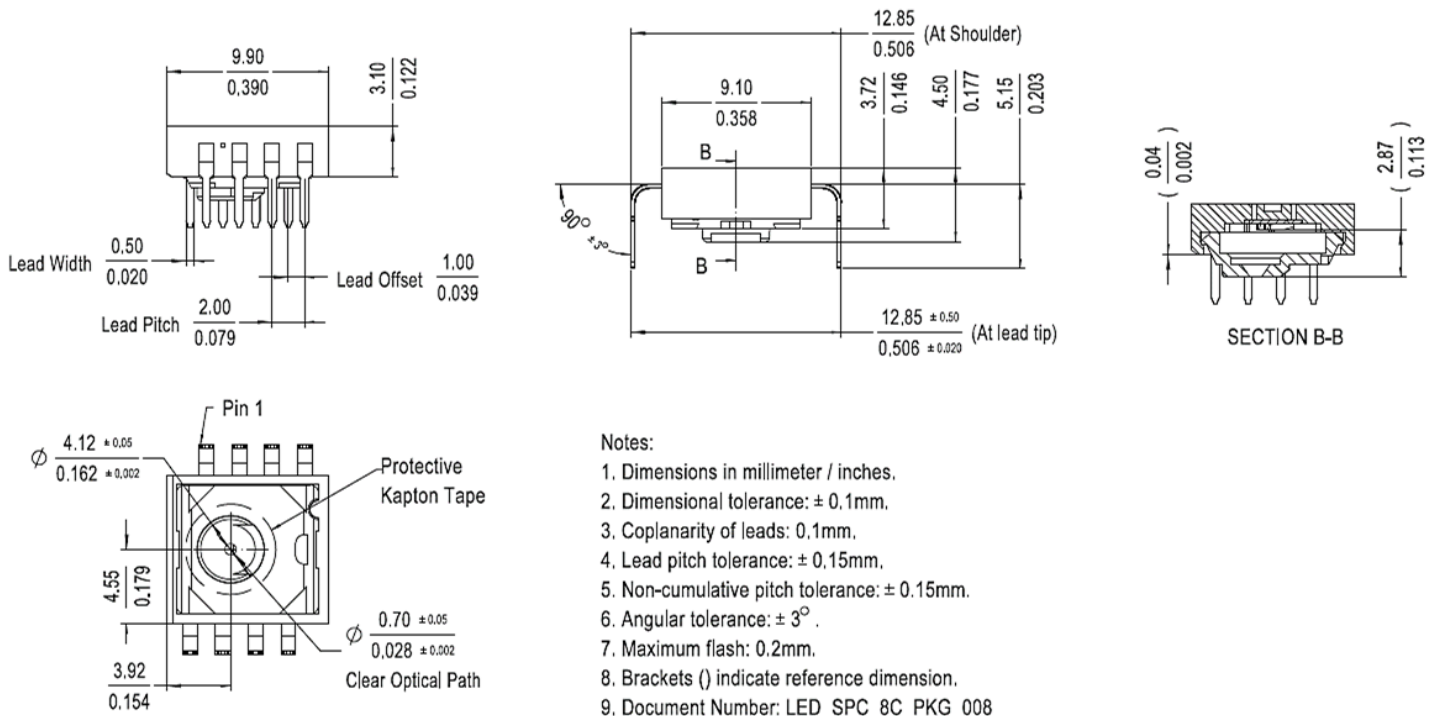

Figure 4. Package Drawing Outline

3.2 Package Marking

Refer to 1.3 Figure 2. Pin Configuration

Table 8. Code Identification

Code	Marking	Description
Product Number	PMW3325DB-TWV1	Part number label
Lot Code	YYWWXXXXX	YYWW=Datecode XXXXX= PixArt Reserved

3.3 Assembly Drawings

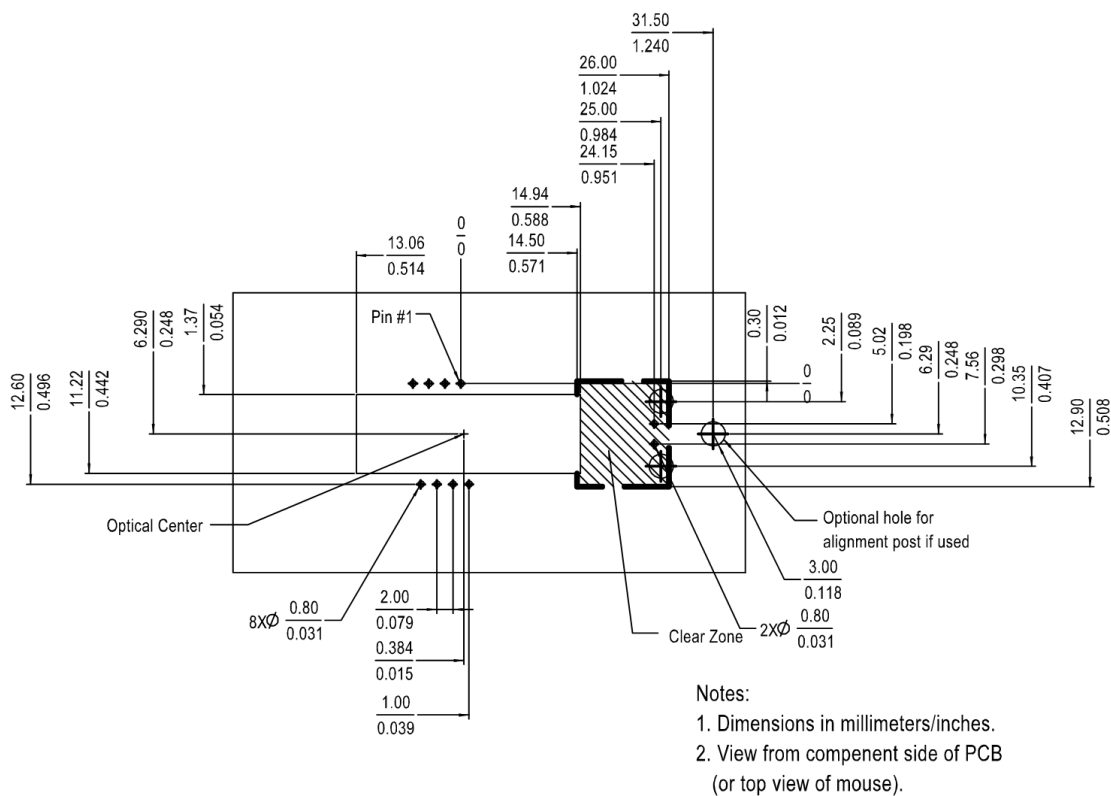
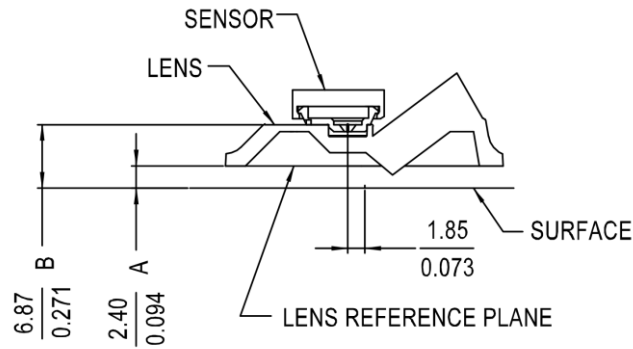

Figure 5. Recommended chip orientation, mechanical cutouts & spacing (Top View)



Note:

- A - Distance from object surface to lens reference plane
- B - Distance from object surface to sensor reference plane

Figure 6. Distance from Lens Reference Plane to Surface

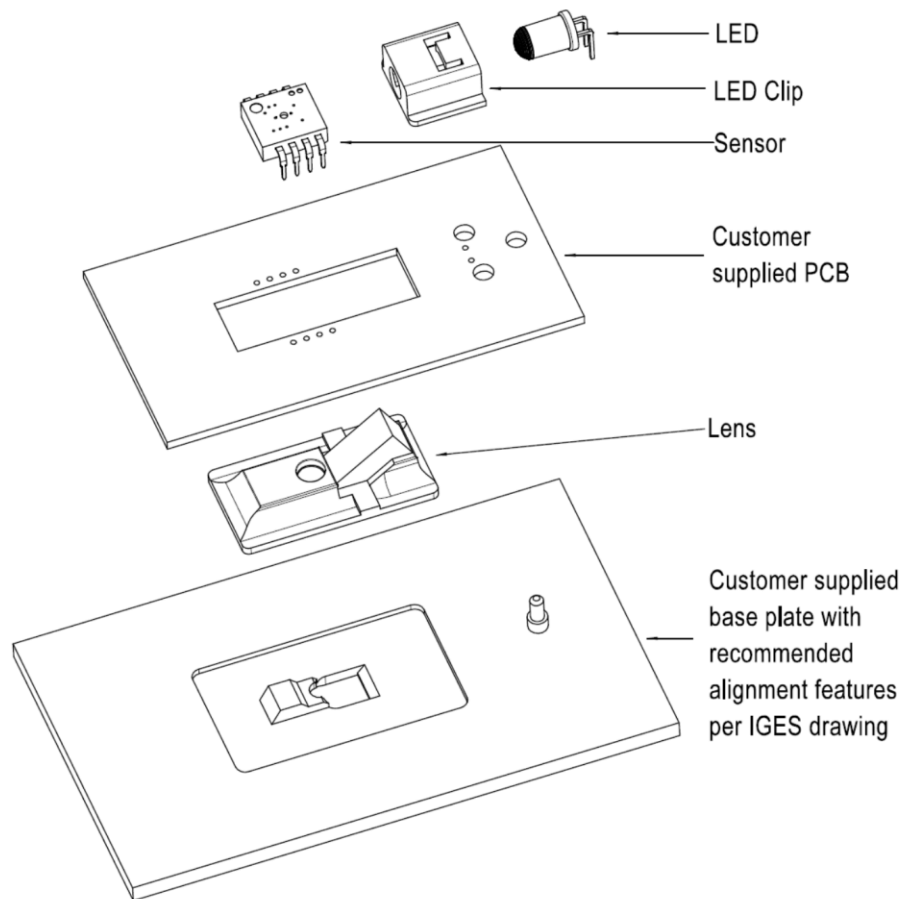
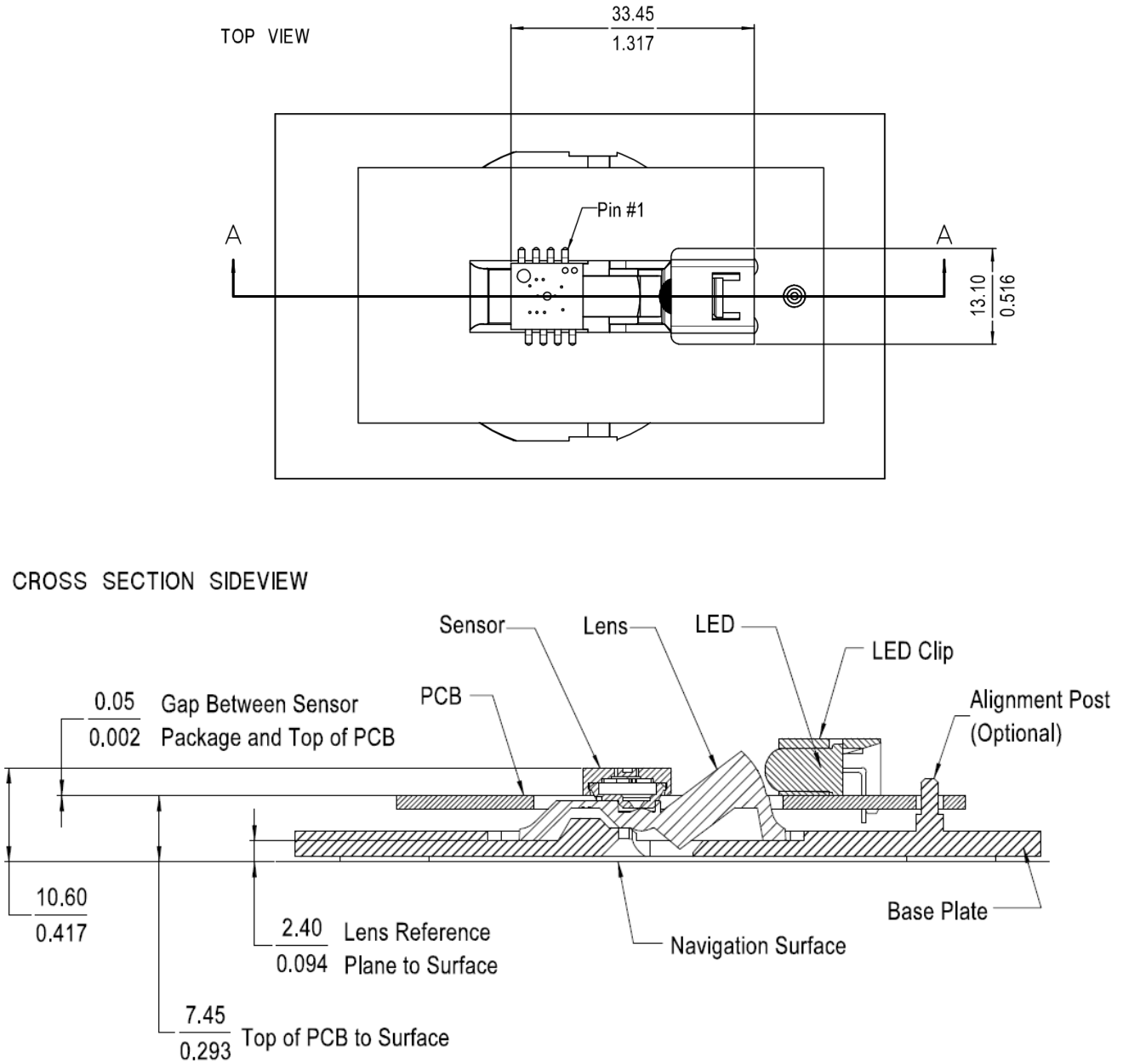

Figure 7. Exploded View of Mouse Assembly



NOTE: Dimensions in mm/inches.

Important Note: Pin 1 of sensor should be located nearest to the LED.

Figure 8. 2D Assembly

Note: Mouse feet should be placed close to the lens opening (hole) to stabilize soft surfaces to be within the working DOF of the chip

3.4 Lens Outline Drawing

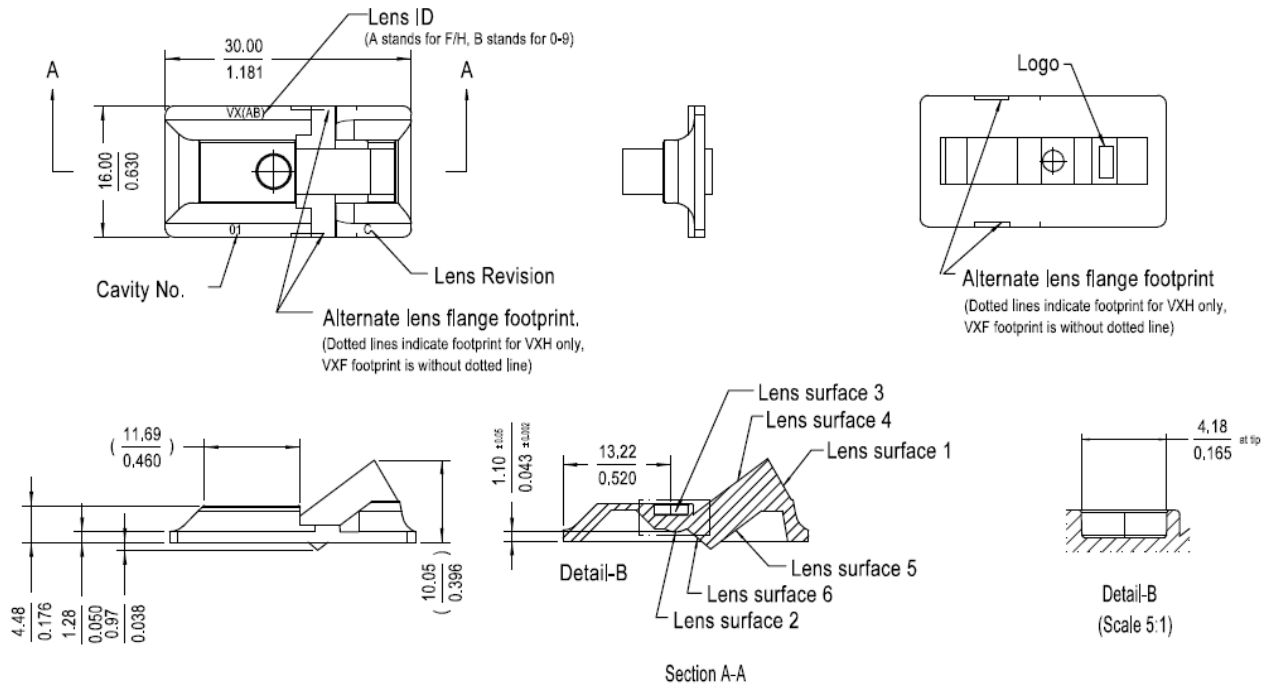

Notes:

1. Dimensions in millimeter / inches
2. Dimensional tolerance: ± 0.1mm
3. Angular tolerance: ± 3°
4. Maximum flash: +0.20mm
5. () reference dimension
6. Optical details of lens not shown.
7. Dotted line indicate alternate lens flange footprint
8. Document number: LM31-LNG-G8_002

Figure 9. LM31-LNG Trim Lens Outline Drawing

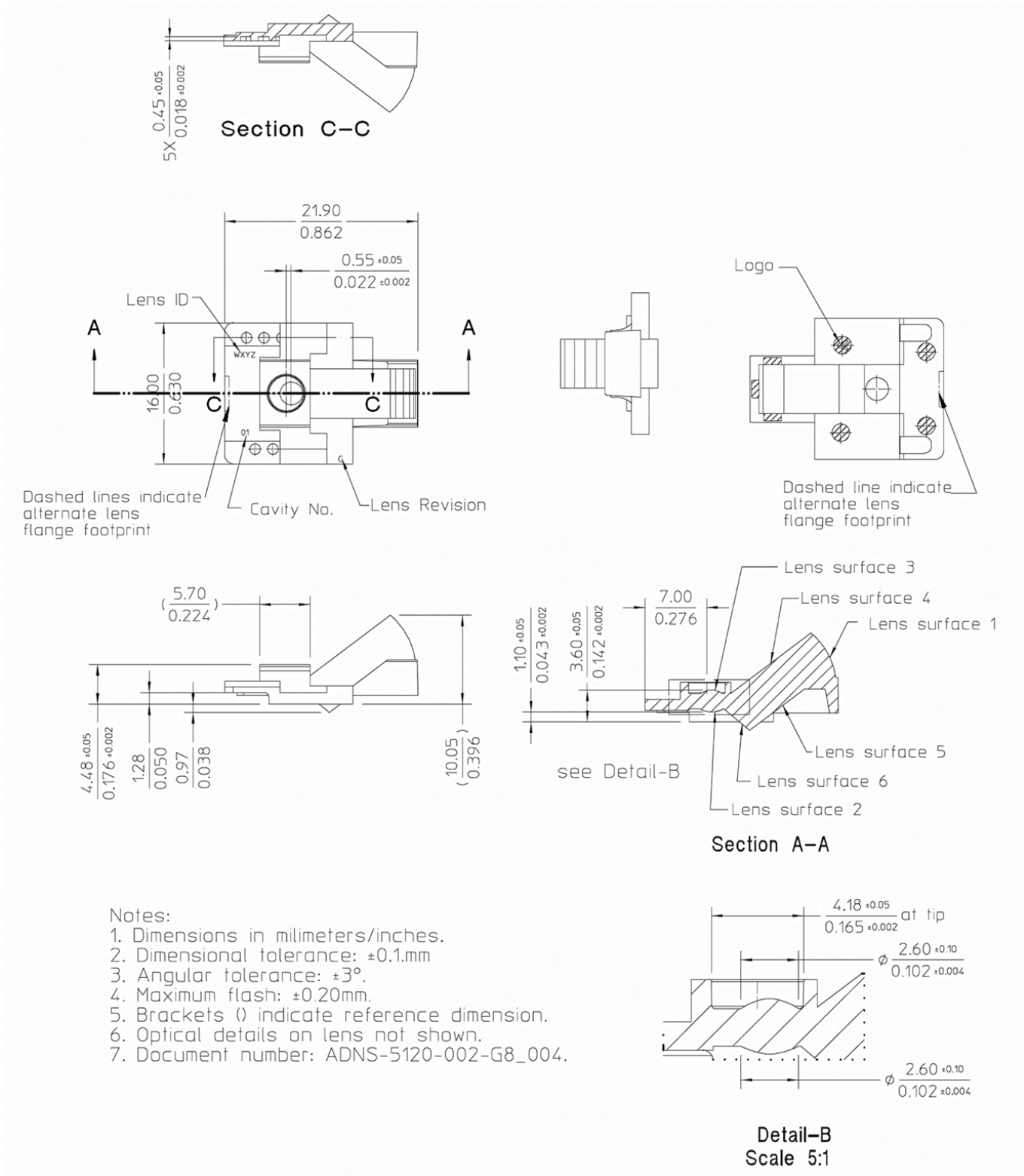

Figure 10. LM33-LSG Small Trim Lens Outline Drawings

4.0 System Level Description

4.1 Reference Application Schematic Diagram

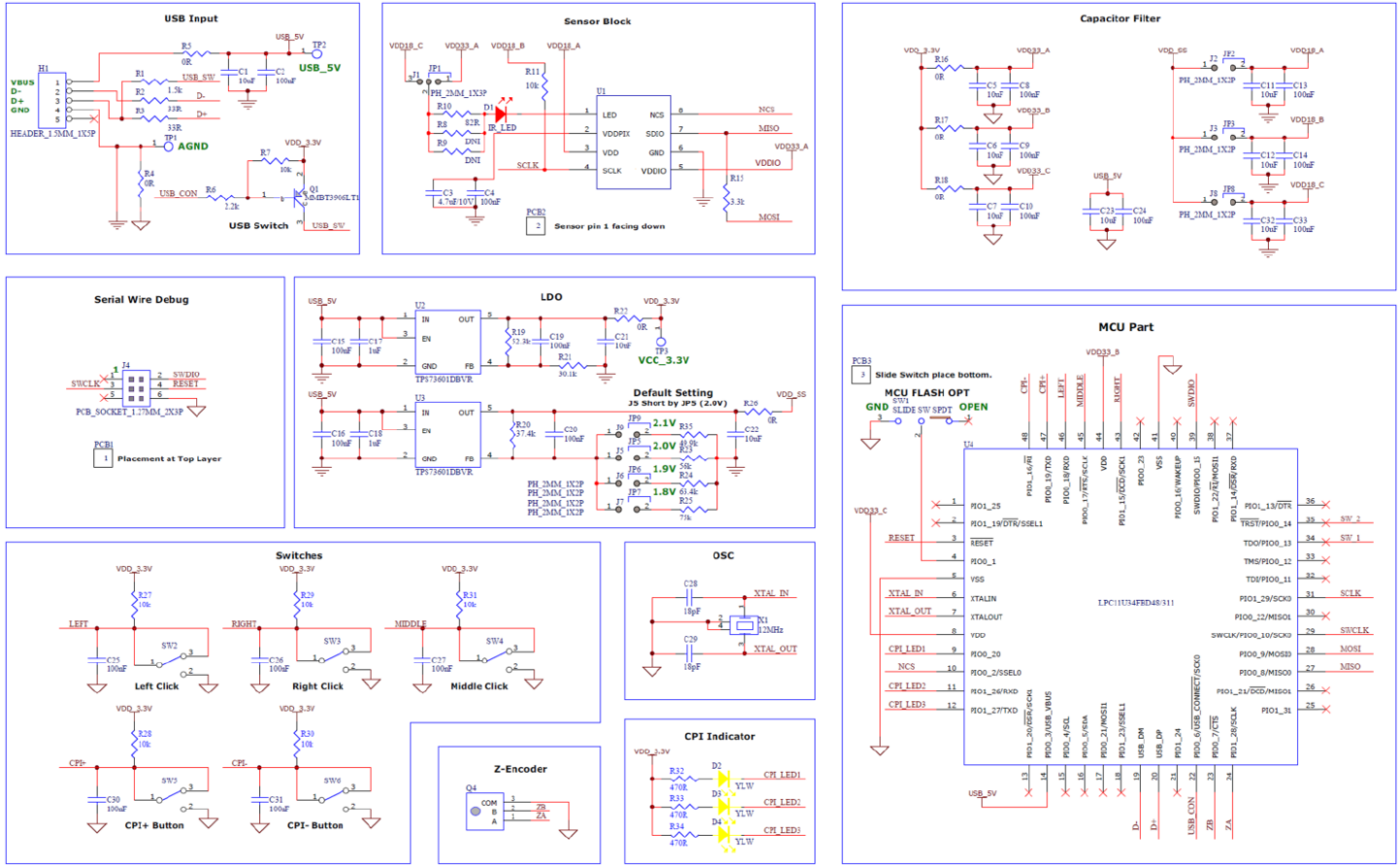

Figure 11. PMW3325DB-TWV1 Reference Mouse Schematic

The R_{LED} value shown in the reference circuit above is used with VDD 1.8V supply connected to LED. For other VDD value, the R_{LED} value has to be adjusted in order to obtain the 8mA current for LED.

4.2 PCB Assembly Recommendation

1. Insert the integrated chip and all other electrical components into PCB.
2. Wave-solder the entire assembly in a no-wash solder process utilizing solder-fixture. A solder-fixture is required to protect the chip from flux spray and wave solder.
3. Avoid getting any solder flux onto the chip body as there is potential for flux to seep into the chip package. The solder fixture should be designed to expose only the chip leads to flux spray & molten solder while shielding the chip body and optical apertures. The fixture should also set the chip at the correct position and height on the PCB.
4. Place the lens onto the base plate. Care must be taken to avoid contamination on the optical surfaces.
5. Remove the protective kapton tapes from optical apertures of the chip. Care must be taken to prevent contaminants from entering the apertures. Do not place the PCB with the chip facing up during the entire product assembly process. Hold the PCB vertically when removing kapton tape.
6. Insert PCB assembly over the lens onto the base plate aligning post to retain PCB assembly. The chip package will self-align to the lens via the guide posts. The optical position reference for the PCB is set by the base plate and lens. Note that the PCB motion due to button presses must be minimized to maintain optical alignment.
7. Install mouse top case. There must be a feature in the top case to press down onto the PCB assembly to ensure all components are stacked or interlocked to the correct vertical height

5.0 Registers

5.1 Registers List

The Chip registers are accessible via the serial port. The registers are used to read motion data and status as well as to set the device configuration.

Table 9. Register List

Address	Register Name	Access	Reset Value
0x00	PRODUCT_ID	R	0x43
0x02	MOTION	RW	0x00
0x03	DELTA_X_L	R	0x00
0x04	DELTA_X_H	R	0x00
0x05	DELTA_Y_L	R	0x00
0x06	DELTA_Y_H	R	0x00
0x07	SQUAL	R	0x00
0x08	PIXEL_SUM	R	0x00
0x09	MAXIMUM_PIXEL	R	0x00
0x0A	MINIMUM_PIXEL	R	0x00
0x0B	SHUTTER_LOWER	R	0x12
0x0C	SHUTTER_UPPER	R	0x00
0x15	CHIP_OBSERVATION	RW	0x80
0x16	BURST_MOTION_READ	R	0x00
0x19	FRAME_CAPTURE_STATUS	R	0x00
0x1B	RESOLUTION	RW	0x2E
0x1E	ANGLE_SNAP	RW	0x04
0x20	AXIS_CONTROL	RW	0x00
0x24	RUN_DOWNSHIFT	RW	0x06
0x25	REST1_PERIOD	RW	0x01
0x26	REST1_DOWNSHIFT	RW	0x4F
0x27	REST2_PERIOD	RW	0x19
0x28	REST2_DOWNSHIFT	RW	0x5E
0x29	REST3_PERIOD	RW	0x3F
0x32	FRAME_CAPTURE	RW	0x00
0x3A	POWER_UP_RESET	W	N/A
0x3B	SHUTDOWN	W	N/A
0x3F	INV_PRODUCT_ID	R	0xBC
0x40	CONFIG	RW	0x00

Document Revision History

Revision Number	Date	Description
1.40	12 Aug 2016	- Initial creation from PMW3325DB-TWV1 DS R1.30 - Added LM33-LSG lens outline drawing