

## General Description

The EC9301H is a series of easy to use fixed and adjustable step-down (buck) switch-mode voltage regulators. These devices are available in fixed output voltage of 5V, and an adjustable output version. Both versions are capable of driving a 3A load with excellent line and load regulation.

Requiring a minimum number of external components, these regulators are simple to use and include internal frequency compensation, and a fixed-frequency oscillator.

The output voltage is guaranteed to  $\pm 3\%$  tolerance under specified input voltage and output load conditions. The oscillator frequency is guaranteed to  $\pm 15\%$ . External shutdown is included, featuring typically 80  $\mu\text{A}$  standby current. Self protection features include a two stage frequency reducing current limit for the output switch and an over temperature shutdown for complete protection under fault conditions.

The EC9301H is available in TO263-5L packages.

## Features

- 5V and adjustable output Versions
- Output adjustable from 1.23V to 57V
- Fixed 150KHz frequency internal oscillator
- Guaranteed 3A output load current
- Input voltage range up to 60V
- Low power standby mode,  $I_Q$  typically 80  $\mu\text{A}$
- TTL shutdown capability
- Excellent line and load regulation
- Requires only 4 external components
- High efficiency
- Thermal shutdown and current limit protection
- Available in TO263 packages

## Applications

- Simple High-efficiency step-down regulator
- On-card switching regulators
- Positive to negative converter
- LCD monitor and LCD TV
- DVD recorder and PDP TV
- Battery charger
- Step-down to 3.3V for microprocessors

## Package Types

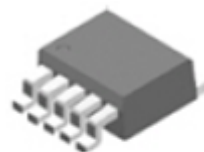

**TO263-5L**

**Figure 1. Package Types of EC9301H**

## Pin Assignment (Top-View)

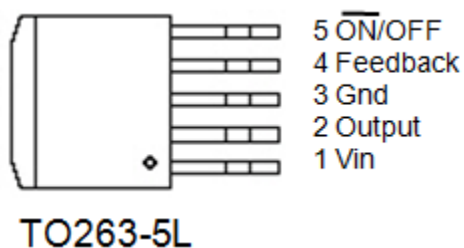
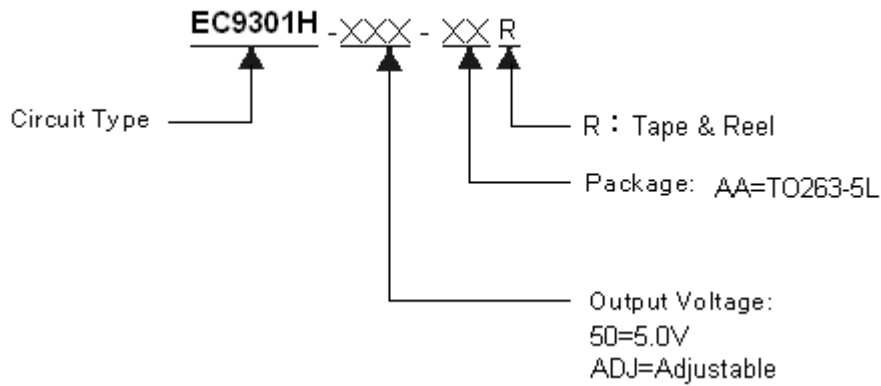

Figure 2. Pin Configuration of EC9301H

## Pin Descriptions

Pin No	Name	Description
1	Vin	Input supply voltage
2	Output	Switching output
3	GND	Ground
4	Feedback	Output voltage feedback
5	ON/OFF	ON/OFF shutdown Active is "Low" or GND

## Ordering/ Marking Information



Package type	Part Number	Marking	Marking Information
TO263-5L	EC9301HXXXAAR (XXX : Output Voltage)	9301H VLLL YYWWT	<ol style="list-style-type: none"> <li>VV is the Output Voltage (50=5.0V;AJ=Adjustable)</li> <li>LLL : last three number of lot no.</li> <li>YYWW : Date Code</li> <li>T : Internal tracking Code</li> </ol>

## Function Block Diagram

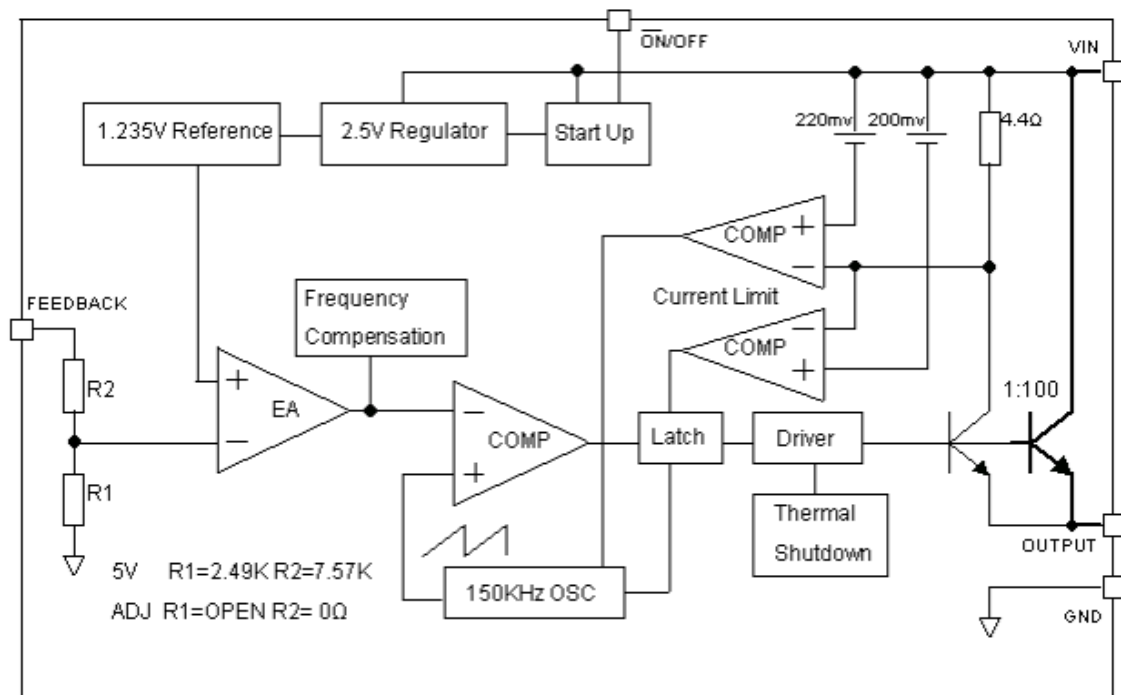

Figure 3 Function Block Diagram of EC9301H



## Absolute Maximum Ratings

Parameter	Symbol	Value	Unit
Input Voltage	$V_{IN}$	-0.3 ~ 60	V
Feedback pin voltage	$V_{FB}$	-0.3 ~ $V_{IN} + 0.3$	V
ON/OFF Pin voltage	$V_{EN}$	-0.3~ 25	V
Output pin voltage	$V_{SW}$	-0.3 ~ $V_{IN} + 0.3$	V
Power Dissipation	$P_D$	Internally limited	mW
Operating Junction Temperature	$T_J$	150	°C
Storage Temperature	$T_{stg}$	-65~+150	°C
Lead Temperature (Soldering, 10 sec)	$T_{Lead}$	260	°C
ESD(HBM)		4000	V
MSL		Level 3	
Thermal Resistance-Junction to Ambient	$R_{\theta JA}$	23	°C/W
Thermal Resistance-Junction to Case	$R_{\theta JA}$	3.5	°C/W

Note1: Stresses greater than those listed under Maximum Ratings may cause permanent damage to the device. This is a stress rating only and functional operation of the device at these or any other conditions above those indicated in the operation is not implied. Exposure to absolute maximum rating conditions for extended periods may affect reliability.

## Recommended Operating Conditions

Parameter	Symbol	Min.	Max.	Unit
Input Voltage	$V_{IN}$	3.6	60	V
Operating Junction Temperature	$T_J$	-40	125	°C
Operating Ambient Temperature	$T_A$	-40	85	°C

## Electrical Characteristics

Specifications with **boldface type** are for full operating temperature range, the other type are for  $T_J=25^{\circ}\text{C}$ .

Note1: Thermal resistance with copper area of approximately 3 in<sup>2</sup>.

Symbol	Parameter	Conditions	Min.	Typ.	Max.	Unit
$I_b$	Feedback bias current	Adjustable only, $V_{FB}=1.3\text{V}$		10	<b>50/100</b>	nA
$I_Q$	Quiescent current	$V_{FB}=12\text{V}$ force driver off		5	10	mA
$I_{STBY}$	Standby quiescent current	ON/OFF=5V, $V_{IN}=36\text{V}$	-	80	<b>200/250</b>	uA
$F_{OSC}$	Oscillator frequency		127	150	173	KHz
$V_{SAT}$	Saturation voltage	$I_{OUT}=3\text{A}$		1.2	<b>1.4/1.5</b>	V
$I_{CL}$	Current Limit	Peak Current ( $V_{FB}=0\text{V}$ )		4.5	<b>5.5/6.5</b>	A
$I_L$	Output leakage current	Output=0V ( $V_{FB}=12\text{V}$ )			50	uA
$I_L$	Output leakage current	Output=-1V ( $V_{IN}=36\text{V}$ )		2	30	mA
$V_{IL}$	ON/OFF pin logic input Threshold voltage	Low (Regulator ON)		1.3	0.6	V
$V_{IH}$		High (Regulator OFF)	2.0	1.3		V
$I_H$	ON/OFF pin input current	$V_{LOGIC}=2.5\text{V}$ (Regulator OFF)		5	15	uA
$I_L$	ON/OFF pin input current	$V_{LOGIC}=0.5\text{V}$ (Regulator ON)		0.02	5	uA
$\theta_{JC}$	Thermal Resistance Junction to Case	TO263-5L		3.5		$^{\circ}\text{C}/\text{W}$
$\theta_{JA}$	Thermal Resistance Junction to Ambient (Note1)	TO263-5L		23		$^{\circ}\text{C}/\text{W}$

## Electrical Characteristics (Continued)

Specifications with **boldface type** are for full operating temperature range, the other type are for  $T_J=25^{\circ}\text{C}$ .

Note1: Thermal resistance with copper area of approximately 3 in<sup>2</sup>.

ADJ	Vout: Output Voltage	$11\text{V} \leq V_{IN} \leq 60\text{V}$ , $0.2\text{A} \leq I_{LOAD} \leq 3\text{A}$ $V_{out}$ for 9V	1.193/ <b>1.180</b>	1.23	1.267/ <b>1.280</b>	V
	$\eta$ : Efficiency	$V_{IN}=12\text{V}$ , $V_{OUT}=9\text{V}$ , $I_{LOAD}=3\text{A}$	-	88	-	%
5V	Vout: Output Voltage	$7\text{V} \leq V_{IN} \leq 60\text{V}$ , $0.2\text{A} \leq I_{LOAD} \leq 3\text{A}$	4.800/ <b>4.750</b>	5.0	5.200/ <b>5.250</b>	V
	$\eta$ : Efficiency	$V_{IN}=12\text{V}$ , $I_{LOAD}=3\text{A}$	-	83	-	%

## Typical Performance Characteristics

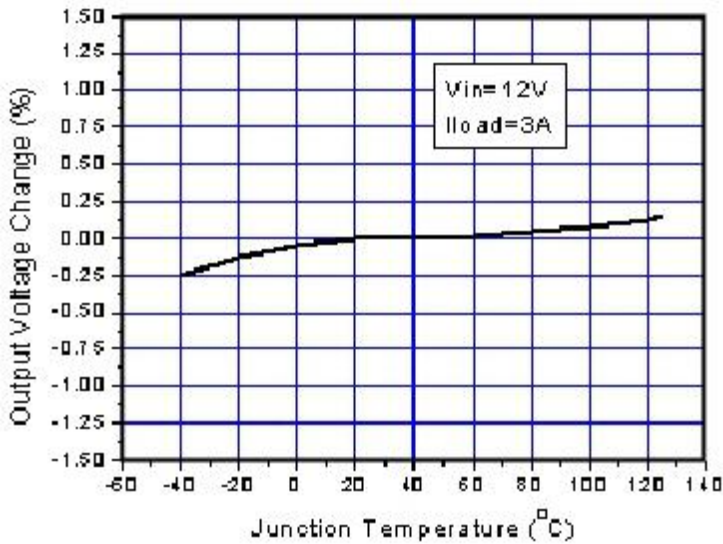

Figure 4. Output Voltage vs. Temperature

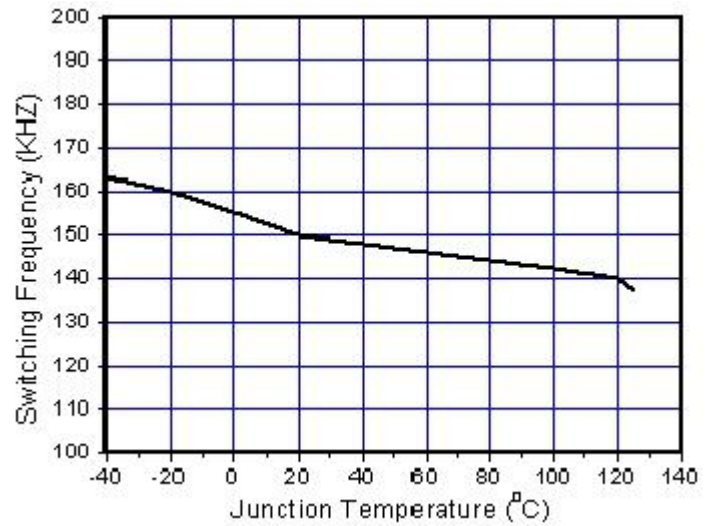

Figure 5. Switching Frequency vs. Temperature

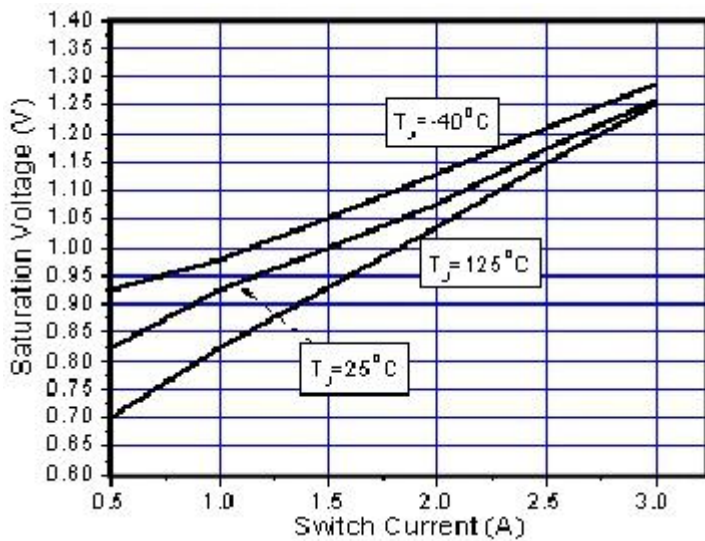

Figure 6. Output Saturation Characteristics

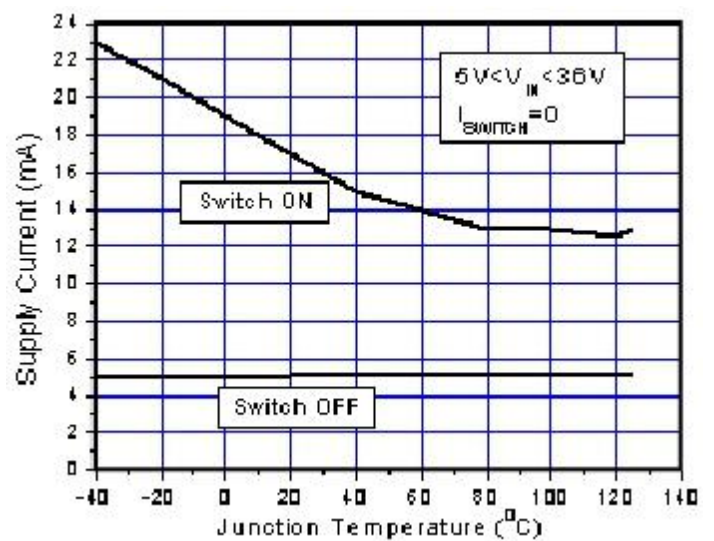

Figure 7. Quiescent Current vs. Temperature

## Typical Performance Characteristics (Continued)

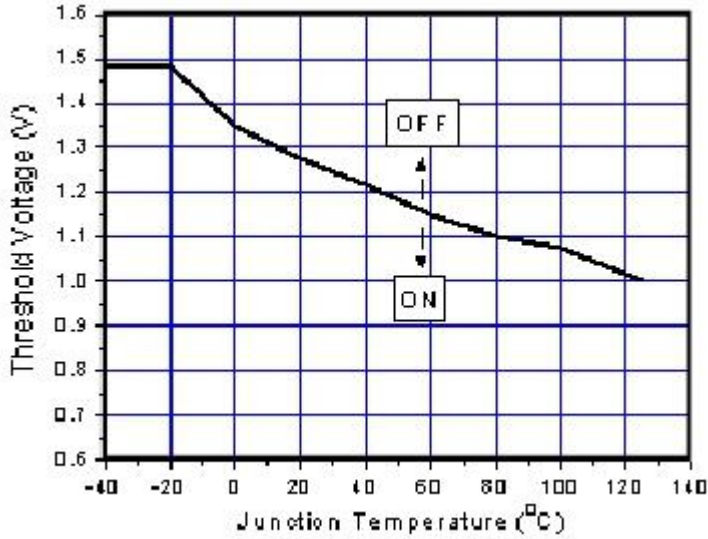

Figure 8. ON/OFF Pin Voltage

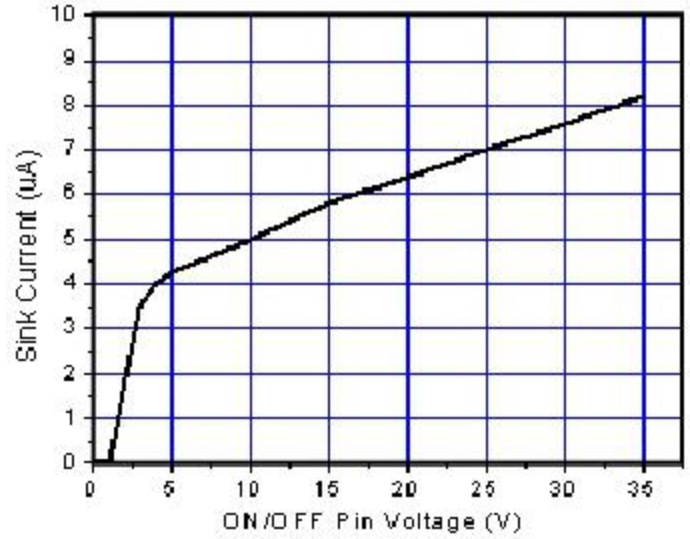

Figure 9. ON/OFF Pin Sink Current

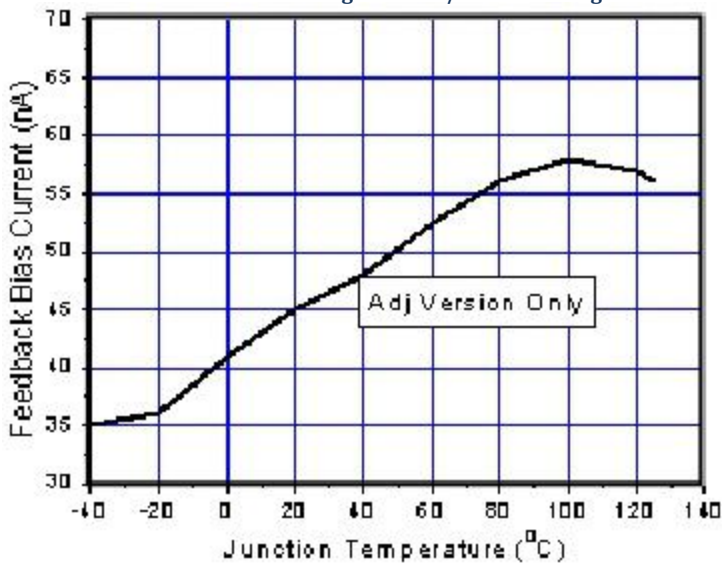

Figure 10. Output Saturation Characteristics

## Typical Application Circuit

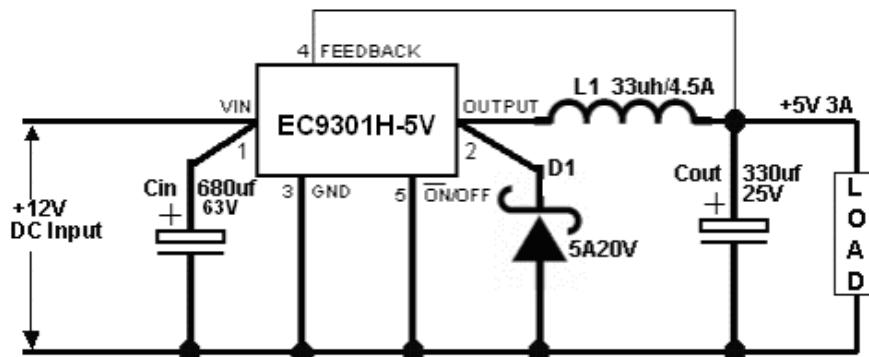
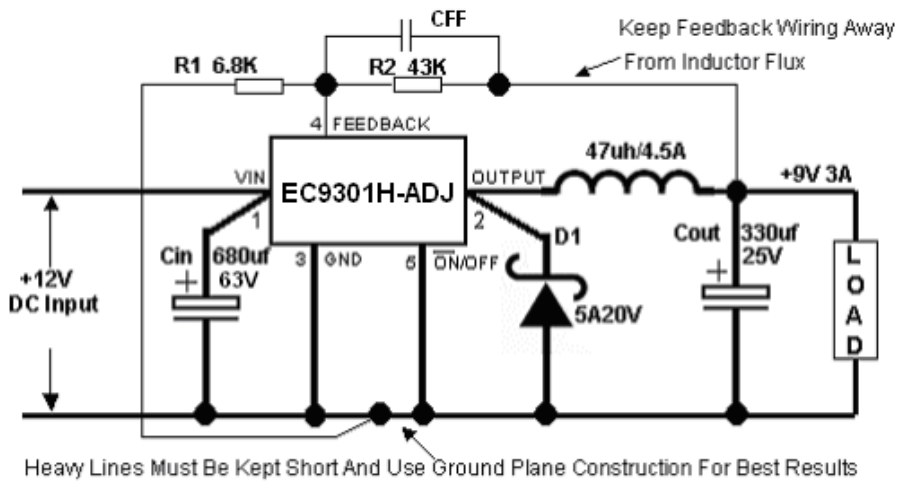

Figure 11. Typical Application of EC9301H For 5V

Input Voltage	Inductor (L1)	Output Capacitor (Cout)	
		Through Hole Electrolytic	Surface Mount Tantalum
8V ~ 18V	33uH	330uF/25V	220uF/10V
8V ~ 60V	47uH	470uF/25V	330uF/10V

Table 1. EC9301H Series Buck Regulator Design Procedure For 5V





$$V_{out} = V_{ref}(1+R2/R1) \quad (\text{Where } V_{ref}=1.23V; C_f=1.5nf)$$

Figure 12. Typical Application of EC9301H For ADJ

Note: In PCB layout. Reserved an area for CFF

Vout	R1	R2	Cf (Operational)
3.3V	1.6K	2.7K	33nf
5V	3.6K	11K	10nf
9V	6.8K	43K	1.5nf
12V	1.5K	13K	1nf

Table 2. Vout VS. R1, R2, Cf Select Table

Output Voltage	Input Voltage	Inductor (L1)	Output Capacitor (Cout)
			Through Hole Electrolytic
3.3V	6V ~ 18V	47uh	470uf/25V
	6V ~ 60V	68uh	560uf/25V
5V	8V ~ 18V	33uh	330uf/25V
	8V ~ 60V	47uh	470uf/25V
9V	12V ~ 18V	47uh	330uf/25V
	12V ~ 60V	47uh	470uf/25V
12V	15V ~ 18V	47uh	220uf/25V
	15V ~ 60V	47uh	330uf/25V

Table 3. Typical Application Buck Regulator Design Procedure

## Function Description

### Pin Functions

#### +VIN

This is the positive input supply for the IC switching regulator. A suitable input bypass capacitor must be present at this pin to minimize voltage transients and to supply the switching currents needed by the regulator

#### Ground

Circuit ground.

#### Output

Internal switch. The voltage at this pin switches between  $(+V_{IN} - V_{SAT})$  and approximately  $-0.5V$ , with a duty cycle of approximately  $V_{OUT} / V_{IN}$ . To minimize coupling to sensitive circuitry, the PC board copper area connected to this pin should be kept a minimum.

#### Feedback

Senses the regulated output voltage to complete the feedback loop.

#### ON/OFF

Allows the switching regulator circuit to be shutdown using logic level signals thus dropping the total input supply current to approximately 80uA. Pulling this pin below a threshold voltage of approximately 1.3V turns the regulator on, and pulling this pin above 1.3V (up to a maximum of 25V) shuts the regulator down. If this shutdown feature is not needed, the ON /OFF pin can be wired to the ground pin or it can be left open, in either case the regulator will be in the ON condition.

### Thermal Considerations

The EC9301H is available in a 5-Pin surface mount TO263. The TO263 surface mount package tab is designed to be soldered to the copper on a printed circuit board. The copper and the board are the heat sink for this package and the other heat producing components, such as the catch diode and inductor. The PC board copper area that the package is soldered to should be at least  $0.4 \text{ in}^2$  and ideally should have 2 or more square inches of 2 oz. Additional copper area improves the thermal characteristics, but with copper areas greater than approximately  $6 \text{ in}^2$ , only small improvements in heat dissipation are realized. If further thermal improvements are needed, double sided, multilayer PC board with large copper areas and/or airflow are recommended.

The EC9301H (TO263 package) junction temperature rise above ambient temperature with a 3A load for various input and output voltages. This data was taken with the circuit operating as a buck switching regulator with all components mounted on a PC board to simulate the junction temperature under actual operating conditions. This curve can be used for a quick check for the approximate junction temperature for various conditions, but be aware that there are many factors that can affect the junction temperature. When load currents higher than 3A are used, double sided or multilayer PC boards with large copper areas and/or airflow might be needed, especially for high ambient temperatures and high output voltages.

For the best thermal performance, wide copper traces and generous amounts of printed circuit board copper should be used in the board layout. (Once exception to this is the output (switch) pin, which should not have large areas of copper.) Large areas of copper provide the best transfer of heat (lower thermal resistance) to the surrounding air, and moving air lowers the thermal resistance even further.

## Function Description(Cont.)

### Setting the Output Voltage

The output voltage is set using a resistive voltage divider from the output voltage to FB(EC9301H-ADJ) The voltage divider divides the output voltage down by the ratio:

$$V_{FB} = V_{OUT} * R1 / (R1 + R2)$$

Thus the output voltage is:

$$V_{OUT} = 1.235 * (R1 + R2) / R1$$

R1 can be as high as 100K $\Omega$ , but a typical value is 10K $\Omega$ .

Using that value, R2 is determined by:

$$R2 \sim 8.18 * (V_{OUT} - 1.235) (K\Omega)$$

For example, for a 3.3V output voltage, R1 is 10K $\Omega$ , and R2 is 17K $\Omega$ .

### Inductor

The inductor is required to supply constant current to the output load while being driven by the switched input voltage. A larger value inductor results in less ripple current that in turn results in lower output ripple voltage. However, the larger value inductor has a larger physical size, higher series resistance, and/or lower saturation current. Choose an inductor that does not saturate under the worst-case load conditions. A good rule for determining the inductance is to allow the peak-to-peak ripple current in the inductor to be approximately 30% of the maximum load current. Also, make sure that the peak inductor current (the load current plus half the peak to peak inductor ripple current) is below the TBDA minimum current limit. The inductance value can be calculated by the equation:

$$L = (V_{OUT}) * (V_{IN} - V_{OUT}) / V_{IN} * f * \Delta I$$

Where V<sub>OUT</sub> is the output voltage, V<sub>IN</sub> is the input voltage, f is the switching frequency, and  $\Delta I$  is the peak-to-peak inductor ripple current.

### Input Capacitor

The input current to the step-down converter is discontinuous, and so a capacitor is required to supply the AC current to the step-down converter while maintaining the DC input voltage. A low ESR capacitor is required to keep the noise at the IC to a minimum. Ceramic capacitors are preferred, but tantalum or low-ESR electrolytic capacitors may also suffice. The input capacitor value should be greater than 10 $\mu$ F. The capacitor can be electrolytic, tantalum or ceramic. However since it absorbs the input switching current it requires an adequate ripple current rating. Its RMS current rating should be greater than approximately 1/2 of the DC load current.

For insuring stable operation should be placed as close to the IC as possible. Alternately a smaller high quality ceramic 0.1 $\mu$ F capacitor may be placed closer to the IC and a larger capacitor placed further away. If using this technique, it is recommended that the larger capacitor be a tantalum or electrolytic type. All ceramic capacitors should be placed close to the EC9301H.

### Output Capacitor

The output capacitor is required to maintain the DC output voltage. Low ESR capacitors are preferred to keep the output voltage ripple low. The characteristics of the output capacitor also affect the stability of the regulation control system. Ceramic, tantalum, or low ESR electrolytic capacitors are recommended. In the case of ceramic capacitors, the impedance at the switching frequency is dominated by the capacitance,

## Function Description(Cont.)

and so the output voltage ripple is mostly independent of the ESR. The output voltage ripple is estimated to be:

$$VRIPPLE \approx 1.4 * VIN * (fLC/fSW)^2$$

Where VRIPPLE is the output ripple voltage, VIN is the input voltage, fLC is the resonant frequency of the LC filter, fSW is the switching frequency. In the case of tantalum or low-ESR electrolytic capacitors, the ESR dominates the impedance at the switching frequency, and so the output ripple is calculated as:

$$VRIPPLE \approx \Delta I * RESR$$

Where VRIPPLE is the output voltage ripple,  $\Delta I$  is the inductor ripple current, and RESR is the equivalent series resistance of the output capacitors.

## Output Rectifier Diode

The output rectifier diode supplies the current to the inductor when the high-side switch is off. To reduce losses due to the diode forward voltage and recovery times, use a Schottky rectifier.

Table 1 provides the Schottky rectifier part numbers based on the maximum input voltage and current rating. Choose a rectifier whose maximum reverse voltage rating is greater than the maximum input voltage, and whose current rating is greater than the maximum load current.

## Feedforward Capacitor (CFF)

For output voltages greater than approximately 8V, an additional capacitor is required. The compensation capacitor is typically between 100 pF and 33 nF, and is wired in parallel with the output voltage setting resistor, R2. It provides additional stability for high output voltages, low input-output voltages, and/or very low ESR

output capacitors, such as solid tantalum capacitors.

$$C_{FF} = \frac{1}{31 \times 10^3 \times R_2}$$

This capacitor type can be ceramic, plastic, silver mica, etc. (Because of the unstable characteristics of ceramic capacitors made with Z5U material, they are not recommended.)

Note: In PCB layout, reserved an area for CFF.

## Over Current Protection (OCP)

The cycle by cycle current limit threshold is set between 4A and 5A. When the load current reaches the current limit threshold, the cycle by cycle current limit circuit turns off the high side switch immediately to terminate the current duty cycle. The inductor current stops rising. The cycle by cycle current limit protection directly limits inductor peak current. The average inductor current is also limited due to the limitation on peak inductor current. When the cycle by cycle current limit circuit is triggered, the output voltage drops as the duty cycle is decreasing.

## Thermal Management and Layout

### Consideration

In the EC9301H buck regulator circuit, high pulsing current flows through two circuit loops. The first loop starts from the input capacitors, to the VIN pin, to the VOUT pins, to the filter inductor, to the output capacitor and load, and then returns to the input capacitor through ground. Current flows in the first loop when the high side switch is on. The second loop starts from the inductor, to the output capacitors and load, to the GND pin of the EC9301H, and to the VOUT pins of the EC9301H. Current flows in the second loop when the low side diode is on. In PCB layout, minimizing the two loops area reduces the

## Function Description(Cont.)

noise of this circuit and improves efficiency. A ground plane is recommended to connect input capacitor, output capacitor, and GND pin of the EC9301H.

In the EC9301H buck regulator circuit, the two major power dissipating components are the EC9301H and output inductor. The total power dissipation of converter circuit can be measured by input power minus output power.

$$P_{total\_loss} = V_{IN} \times I_{IN} - V_O \times I_O$$

The power dissipation of inductor can be approximately calculated by output current and DCR of inductor.

$$P_{inductor\_loss} = I_O^2 \times R_{inductor} \times 1.1$$

The junction to ambient temperature can be got from power dissipation in the EC9301H and thermal impedance from junction to ambient.

$$T_{(jun-amb)} = (P_{totalloss} - P_{inductorloss}) \times \Theta_{JA}$$

The maximum junction temperature of EC9301H is 145°C, which limits the maximum load current capability. Please see the thermal de-rating curves for the maximum load current of the EC9301H under different ambient temperatures.

The thermal performance of the EC9301H is strongly affected by the PCB layout. Extra care should be taken by users during the design process to ensure that the IC will operate under the recommended environmental conditions.

Several layout tips are listed below for the best electric and thermal performance.

1. Do not use thermal relief connection to the VIN and the GND pin. Pour a maximized copper area to the GND pin and the VIN pin to help thermal dissipation.
2. Input capacitor should be connected to the VIN pin and the GND pin as close as possible.
3. Make the current trace from VOUT pins to L to the GND as short as possible.
4. Pour copper plane on all unused board area and connect it to stable DC nodes, like VIN, GND, or VOUT.
5. Keep sensitive signal traces such as trace connecting FB pin away from the VOUT pins.

## OUTLINE DRAWING FOR TO263-5L

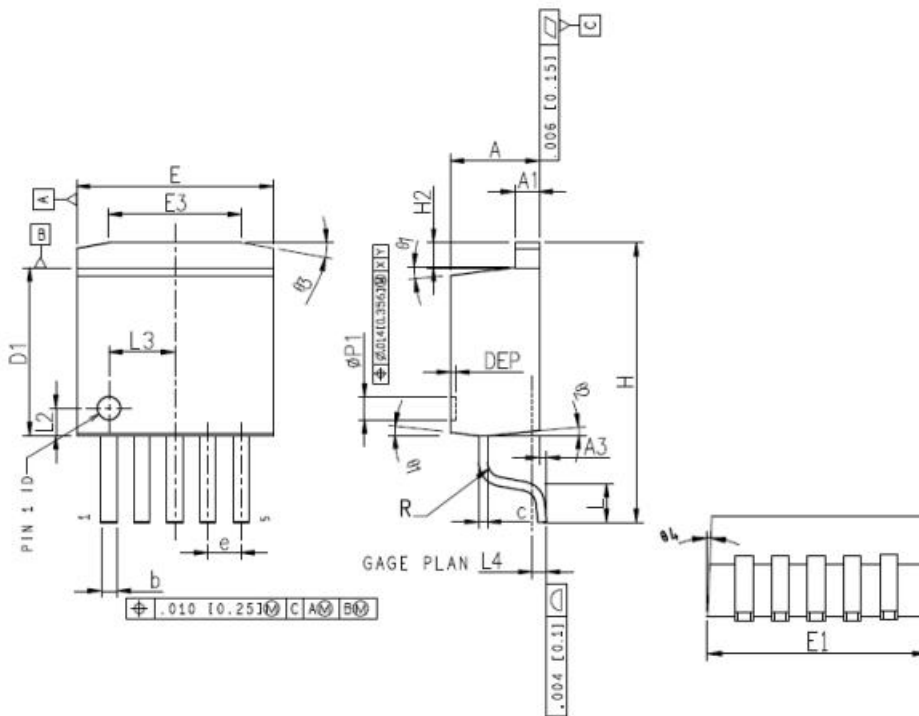

NOTES:  
 1. ALL DIMENSIONS REFER TO JEDEC STANDARD TO-263, DO NOT INCLUDE MOLD FLASH OR PROTRUSIONS.

COMMON DIMENSIONS

SYMBOL	MM			INCH		
	MIN	NOM	MAX	MIN	NOM	MAX
A	4.45	4.57	4.70	0.175	0.180	0.185
A1	1.22	1.27	1.32	0.048	0.050	0.052
A3	0	-	0.15	0.000	-	0.006
b	0.71	-	0.97	0.028	-	0.038
c	0.38	-	0.76	0.015	-	0.030
D1	8.38	8.70	8.89	0.330	0.343	0.350
E	9.91	10.16	10.39	0.390	0.400	0.410
E1	10.03	10.16	10.54	0.395	0.400	0.415
E3	6.61	6.86	7.11	0.260	0.270	0.280
e	1.70BSC			0.067BSC		
H	-	-	14.35	-	-	0.565
H2	-	-	1.27	-	-	0.050

L	-	1.98	-	-	0.078	-
L2	1.47REF			0.058REF		
L3	3.40REF			0.134REF		
L4	-	0.76	-	-	0.030	-
φp1	1.07	1.20	1.32	0.042	0.047	0.052
R	-	-	0.76	-	-	0.030
θ1	-	7°	-	-	7°	-
θ2	-	3°	-	-	3°	-
θ3	7°	10°	13°	7°	10°	13°
θ4	-	3°	-	-	3°	-
DEP	0.10	0.18	0.25	0.004	0.007	0.010