

IC0603A182R-10

UNCONTROLLED DOCUMENT

PHYSICAL DIMENSIONS:

A	1.60 [.063]	+ 0.15 [.006]
B	0.80 [.031]	+ 0.15 [.006]
C	0.80 [.031]	+ 0.15 [.006]
D	0.30 [.012]	+ 0.20 [.008]

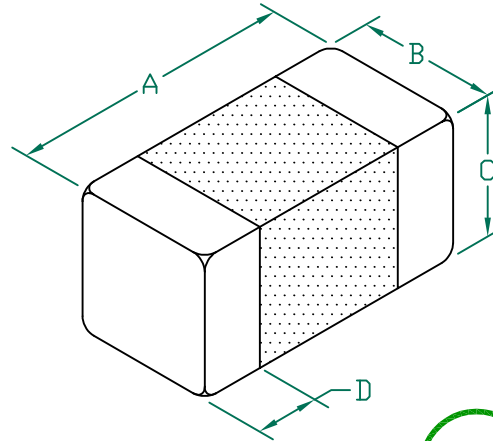

ELECTRICAL CHARACTERISTICS:

L (nH) ± 10%	1,980	Max
	1,800	Nom
	1,620	Min @ 25mA
Q (Min)	30	
Freq. (MHz)	10	
Self-Resonant Freq (MHz)	50	
DCR(Max) Ω	0.95	
I (Max)	100mA	
I (Operating)	25mA	

LAND PATTERNS FOR REFLOW SOLDERING

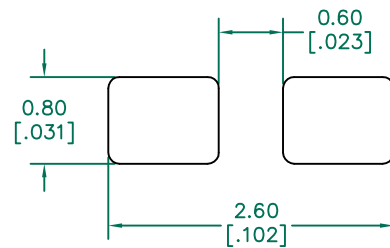

(For wave soldering, add 0.762 [.030] to this dimension)

NOTES: UNLESS OTHERWISE SPECIFIED

1. TAPED AND REELED per CURRENT EIA SPECIFICATIONS 7" REELS, 4000 PCS/REEL, PAPER TAPE.
2. TERMINATION FINISH IS 100% MATTE Sn OVER Ni.
3. COMPONENTS SHOULD BE ADEQUATELY PREHEATED BEFORE SOLDERING.
4. I (MAX.) IS BASED ON THE MAXIMUM SUSTAINED CURRENT APPLIED WHILE MAINTAINING A MAXIMUM TEMPERATURE RISE OF 40°C OVER AMBIENT.
5. I (OPERATING) IS BASED ON THE MAXIMUM SUSTAINED CURRENT APPLIED WHILE MAINTAINING A MINIMUM INDUCTANCE (L).
6. OPERATING TEMP. RANGE: -40°C~+125°C. (INCLUDING SELF-HEATING)

RECOMMENDED SOLDERING CONDITIONS

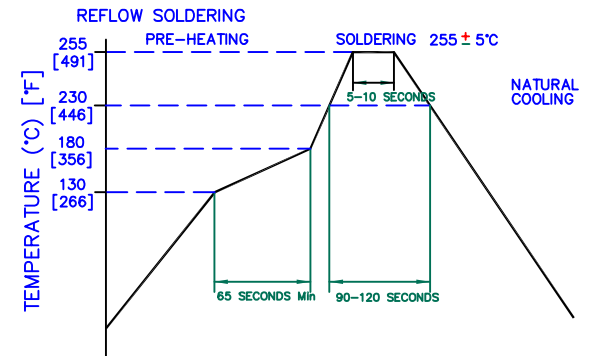

DIMENSIONS ARE IN mm [INCHES].				This print is the property of Laird Tech. and is loaned in confidence subject to return upon request and with the understanding that no copies shall be made without the written consent of Laird Tech. All rights to design or invention are reserved.				Laird		
D	ADD OPERATING TEMPERATURE UPDATE LAIRD LOGO AND REFLOW CURVE	08/05/13	QU	PROJECT/PART NUMBER: IC0603A182R-10				REV D	PART TYPE: CO-FIRE	DRAWN BY: JRK
C	UPDATE COMPANY LOGO	03/25/08	JRK	DATE: 03/26/01	SCALE: NTS	SHEET: 2 of 2				
B	REMOVE KD FROM P/N ADD NOTES CHG Q &SRF VALUES CHG D DIMENSION	01/16/07	JRK	CAD # IC0603A182R-10-D	TOOL # -					
A	ORIGINAL DRAFT	03/26/01	JRK							
REV	DESCRIPTION	DATE	INT							