

N-Channel Logic Level Enhancement Mode Power MOSFET

MTB6D0N03BI3

BV_{DSS}	30V	
$I_D @ V_{GS}=10V, T_A=25^\circ C$	12A	
$I_D @ V_{GS}=10V, T_C=25^\circ C$	44A	
$R_{DS(on)(TYP)}$	$V_{GS}=10V, I_D=25A$	7.1m Ω
	$V_{GS}=4.5V, I_D=15A$	10.0m Ω

Features

- Single Drive Requirement
- Low On-resistance
- Fast Switching Characteristic
- Repetitive Avalanche Rated
- Pb-free lead plating and halogen-free package

Equivalent Circuit

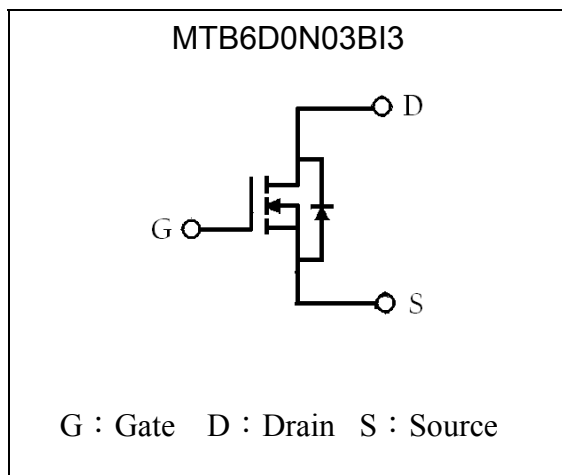

Outline

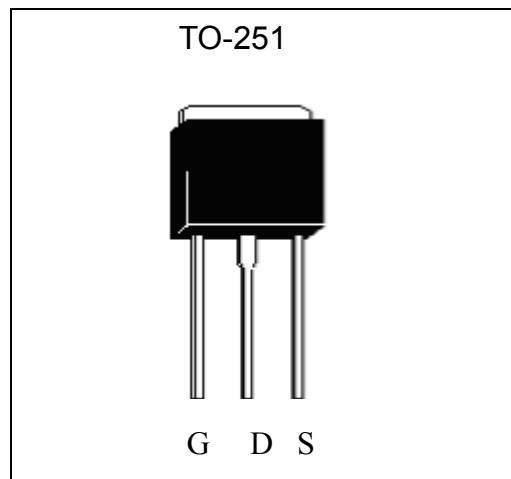

Ordering Information

Device	Package	Shipping
MTB6D0N03BI3-0-UA-G	TO-251 (RoHS compliant and halogen-free package)	80 pcs/tube, 50 tubes/box

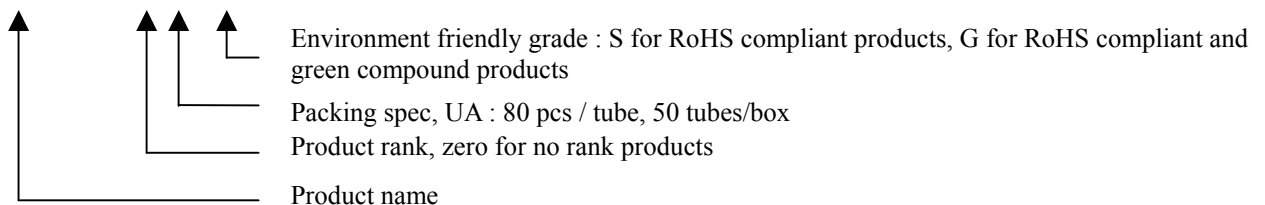



Absolute Maximum Ratings (Ta=25°C, unless otherwise specified)

Parameter	Symbol	Limits	Unit	
Drain-Source Voltage	V _{DS}	30	V	
Gate-Source Voltage	V _{GS}	±20		
Continuous Drain Current @ V _{GS} =10V, T _C =25°C	I _D	44	A	
Continuous Drain Current @ V _{GS} =10V, T _C =100°C		28		
Continuous Drain Current @ V _{GS} =10V, T _A =25°C		12		
Continuous Drain Current @ V _{GS} =10V, T _A =70°C		9.6		
Pulsed Drain Current	I _{DM}	176 *1		
Avalanche Energy @ L=0.1mH, I _D =30A, V _{DD} =15V	E _{AS}	45 *3	mJ	
Repetitive Avalanche Energy @ L=0.05mH	E _{AR}	3.3		
Total Power Dissipation	P _D	T _C =25°C	33	W
		T _C =100°C	13.2	
	P _{DSM}	T _A =25°C	2.5 *2	
		T _A =70°C	1.6 *2	
Operating Junction and Storage Temperature Range	T _j , T _{stg}	-55~+150	°C	

Thermal Data

Parameter	Symbol	Value	Unit
Thermal Resistance, Junction-to-case, max	R _{θJC}	3.8	°C/W
Thermal Resistance, Junction-to-ambient, max	R _{θJA}	50 *2	

- Note : 1. Pulse width limited by maximum junction temperature.
 2. Surface mounted on a 1 in² pad of 2oz copper. In practice R_{thj-a} will be determined by customer's PCB characteristics. 125°C/W when mounted on a minimum pad of 2 oz. copper.
 3. 100% tested by conditions of L=0.1mH, I_{AS}=10A, V_{GS}=10V, V_{DD}=15V, rated 30V

Characteristics (Tc=25°C, unless otherwise specified)

Symbol	Min.	Typ.	Max.	Unit	Test Conditions
Static					
B _V D _{SS}	30	-	-	V	V _{GS} =0V, I _D =250μA
V _{GS(th)}	1	-	2.5		V _{DS} = V _{GS} , I _D =250μA
G _{FS} *1	-	25	-	S	V _{DS} =5V, I _D =15A
I _{GSS}	-	-	±100	nA	V _{GS} =±20V, V _{DS} =0V
I _{DSS}	-	-	1	μA	V _{DS} =24V, V _{GS} =0V
	-	-	10		V _{DS} =24V, V _{GS} =0V, T _j =85°C
R _{DS(ON)} *1	-	7.1	9	mΩ	V _{GS} =10V, I _D =25A
	-	10	15		V _{GS} =4.5V, I _D =15A
Dynamic					
C _{iss}	-	803	-	pF	V _{DS} =15V, V _{GS} =0V, f=1MHz
C _{oss}	-	186	-		
C _{rss}	-	106	-		
Q _g *1, 2	-	8	-	nC	V _{DS} =20V, V _{GS} =4.5V, I _D =33A
Q _{gs} *1, 2	-	2.5	-		
Q _{gd} *1, 2	-	3.8	-		



Characteristics (Tc=25°C, unless otherwise specified)

Symbol	Min.	Typ.	Max.	Unit	Test Conditions
t _{d(ON)} *1, 2	-	7.6	-	ns	V _{DS} =15V, I _D =33A, V _{GS} =10V, R _{GS} =3.3 Ω
t _r *1, 2	-	12.6	-		
t _{d(OFF)} *1, 2	-	26.2	-		
t _f *1, 2	-	7.8	-		
R _g	-	1.9	-	Ω	f=1MHz

Source-Drain Diode

I _S *1	-	-	44	A	
I _{SM} *3	-	-	176		
V _{SD} *1	-	0.88	1.3	V	I _S =25A, V _{GS} =0V
t _{rr}	-	11	-	ns	I _F =20A, dI _F /dt=100A/μs
Q _{rr}	-	5.1	-	nC	

Note : *1.Pulse Test : Pulse Width ≤300μs, Duty Cycle≤2%
 *2.Independent of operating temperature
 *3.Pulse width limited by maximum junction temperature.

Typical Characteristics

Typical Output Characteristics

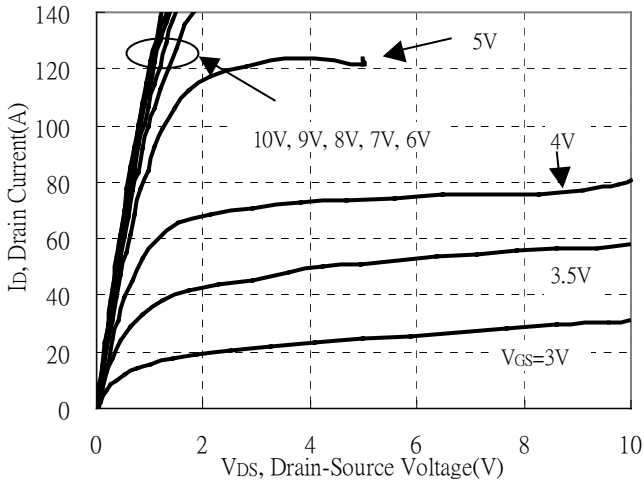

Brekdown Voltage vs Ambient Temperature

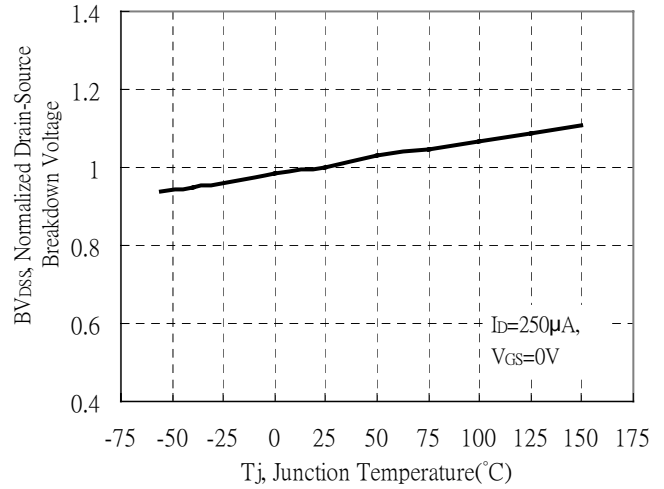

Static Drain-Source On-State resistance vs Drain Current

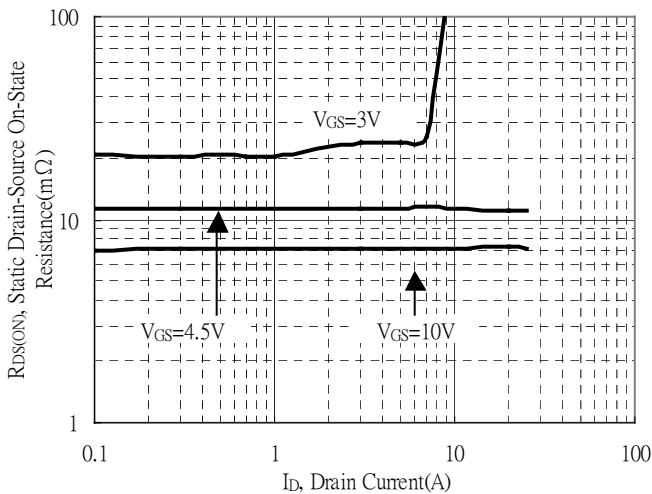

Reverse Drain Current vs Source-Drain Voltage

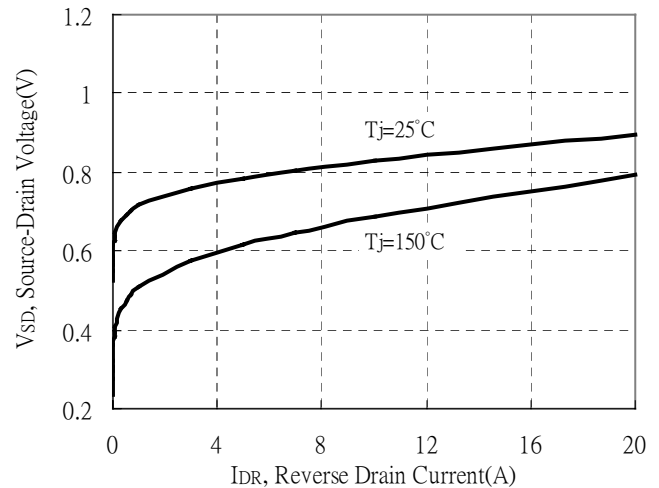

Static Drain-Source On-State Resistance vs Gate-Source Voltage

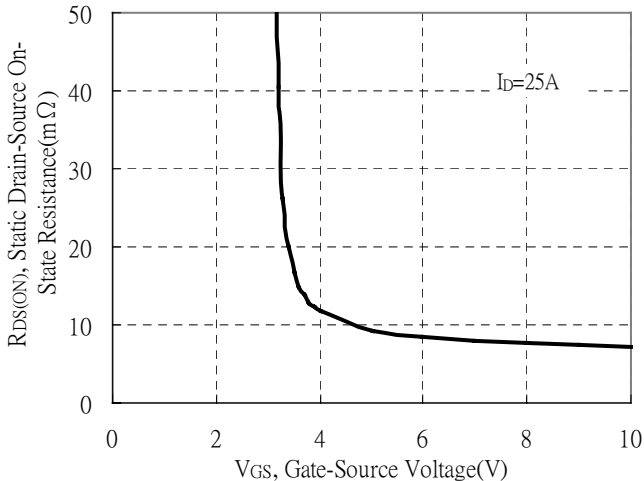

Drain-Source On-State Resistance vs Junction Temperature

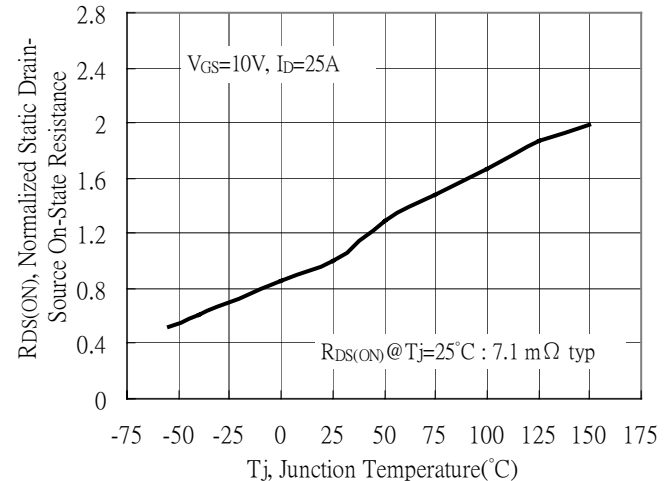

Typical Characteristics(Cont.)

Capacitance vs Drain-to-Source Voltage

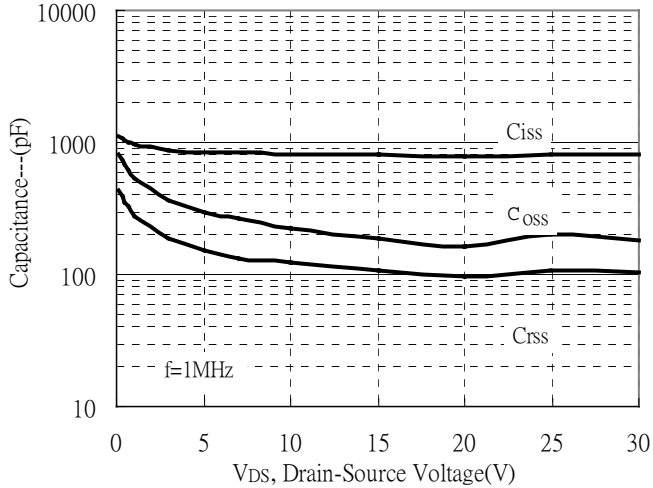

Threshold Voltage vs Junction Temperature

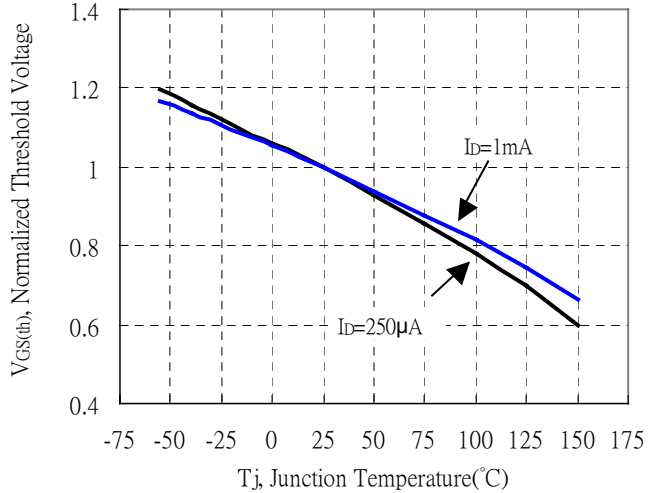

Forward Transfer Admittance vs Drain Current

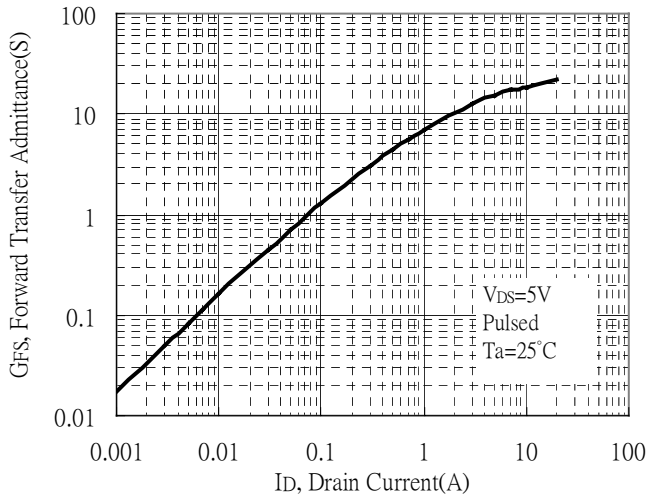

Gate Charge Characteristics

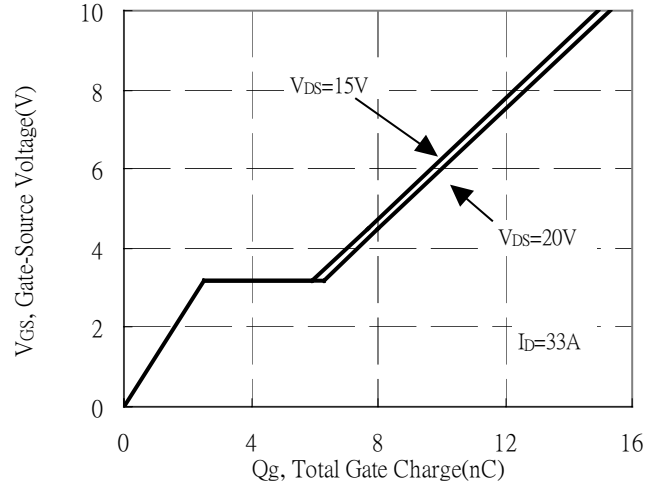

Maximum Safe Operating Area

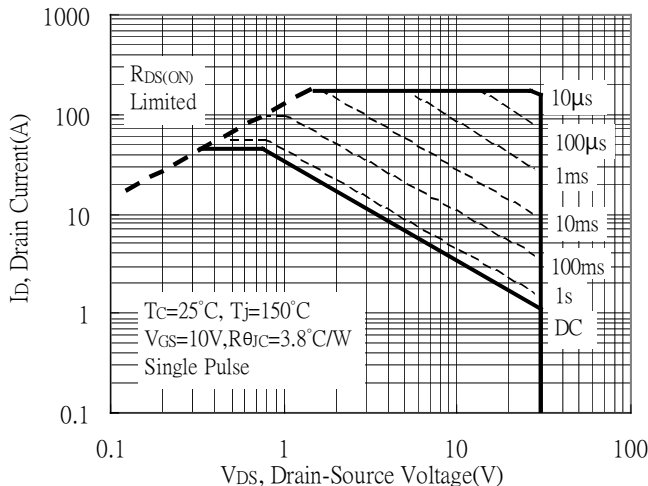

Maximum Drain Current vs Case Temperature

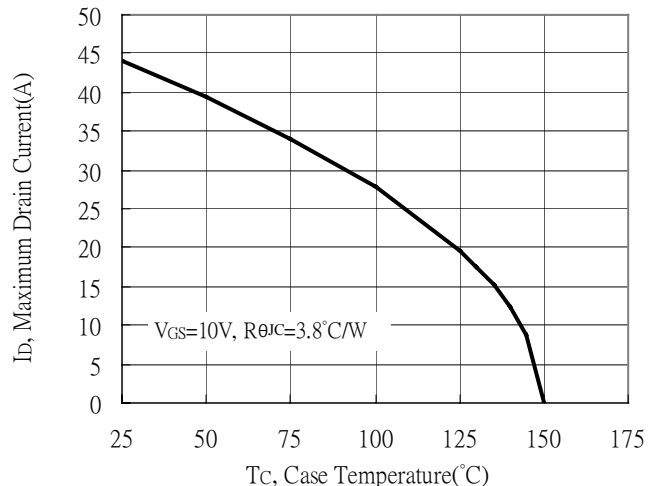



Typical Characteristics(Cont.)

Typical Transfer Characteristics

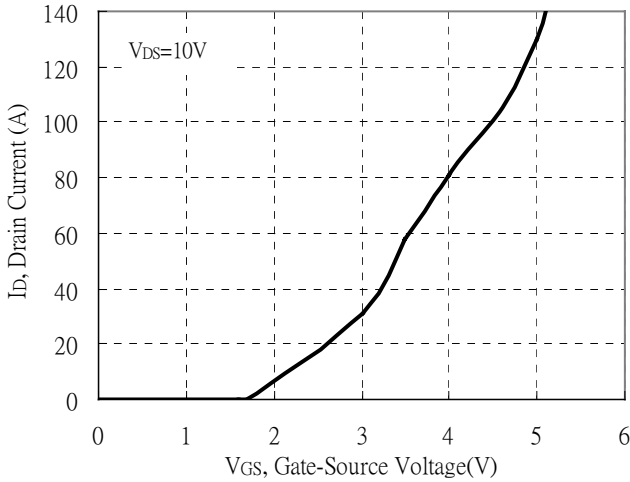

Single Pulse Power Rating, Junction to Ambient
 (Note on page 2)

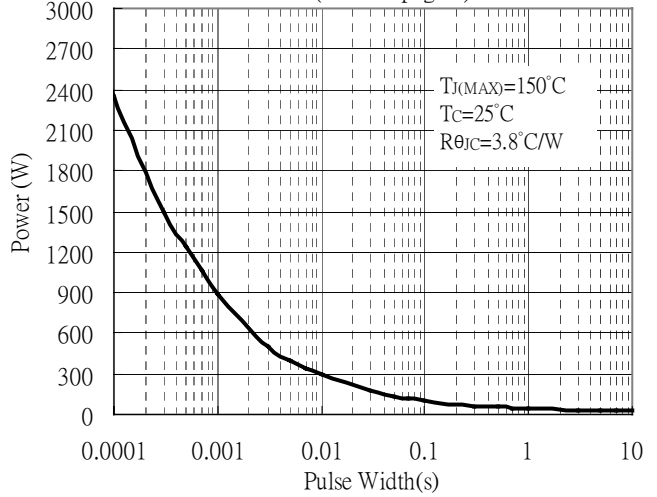

Transient Thermal Response Curves

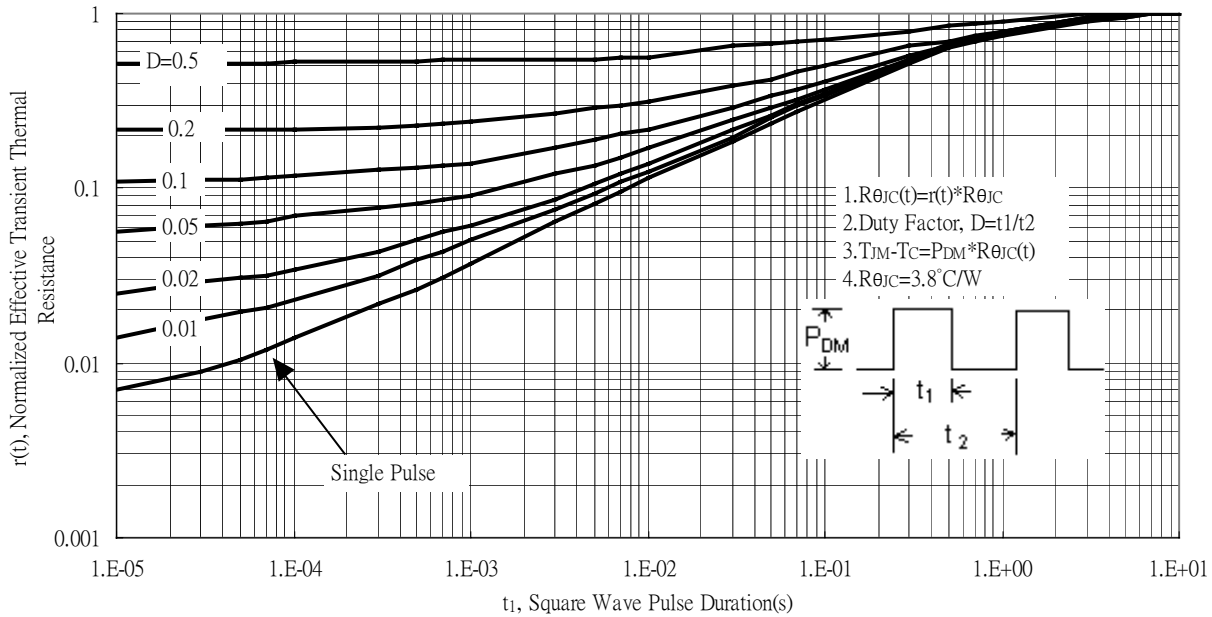

Recommended wave soldering condition

Product	Peak Temperature	Soldering Time
Pb-free devices	260 +0/-5 °C	5 +1/-1 seconds

Recommended temperature profile for IR reflow

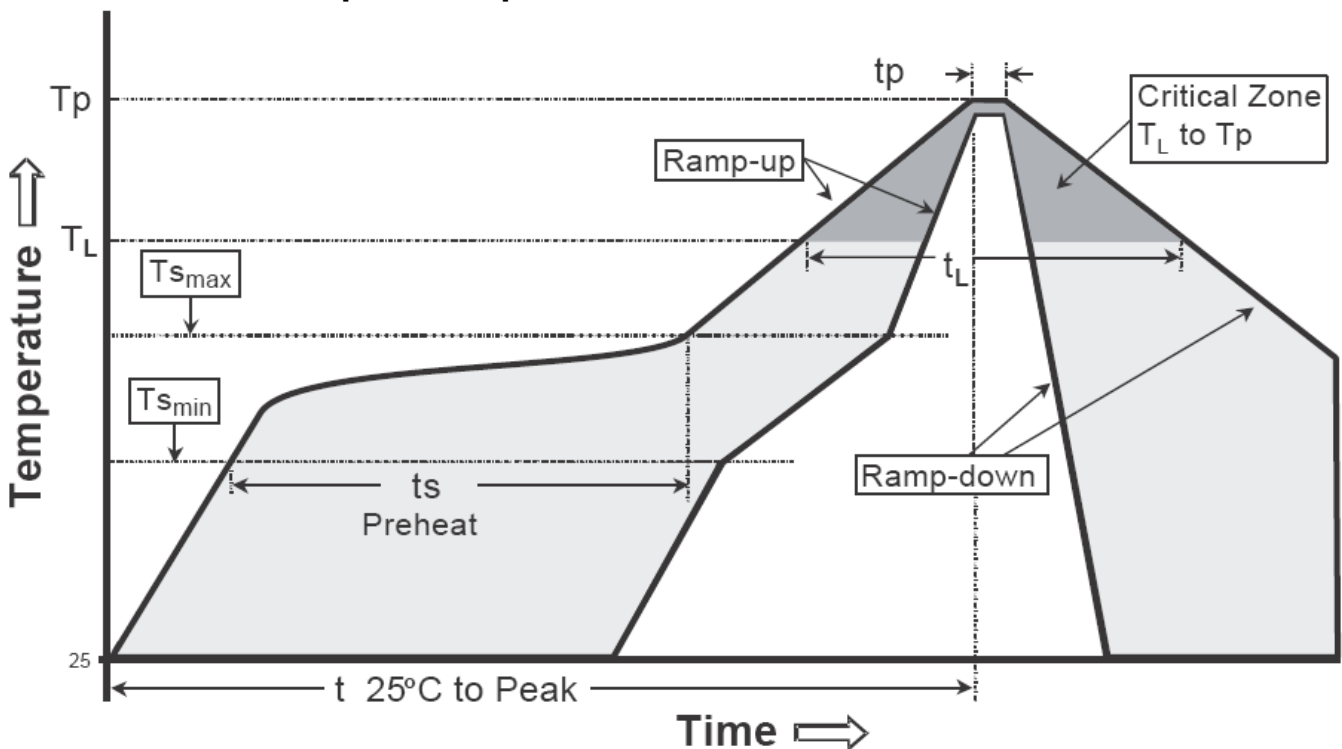

Profile feature	Sn-Pb eutectic Assembly	Pb-free Assembly
Average ramp-up rate (Tsmax to Tp)	3°C/second max.	3°C/second max.
Preheat		
-Temperature Min(Ts min)	100°C	150°C
-Temperature Max(Ts max)	150°C	200°C
-Time(ts min to ts max)	60-120 seconds	60-180 seconds
Time maintained above:		
-Temperature (TL)	183°C	217°C
- Time (tL)	60-150 seconds	60-150 seconds
Peak Temperature(TP)	240 +0/-5 °C	260 +0/-5 °C
Time within 5°C of actual peak temperature(tp)	10-30 seconds	20-40 seconds
Ramp down rate	6°C/second max.	6°C/second max.
Time 25 °C to peak temperature	6 minutes max.	8 minutes max.

Note : All temperatures refer to topside of the package, measured on the package body surface.

TO-251 Dimension

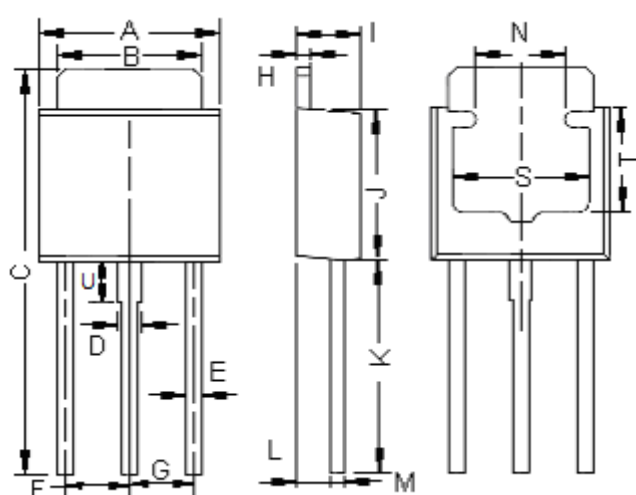

Marking:

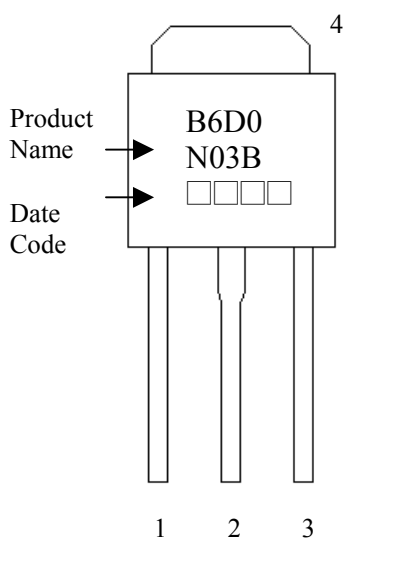

Product Name → B6D0
 N03B
 Date Code → □□□□

1 2 3 4

Style: Pin 1.Gate 2.Drain 3.Source
 4 Drain

3-Lead TO-251 Plastic Package
 CYStek Package Code: I3

DIM	Inches		Millimeters		DIM	Inches		Millimeters	
	Min.	Max.	Min.	Max.		Min.	Max.	Min.	Max.
A	0.250	0.262	6.350	6.650	J	0.213	0.224	5.400	5.700
B	0.205	0.213	5.200	5.400	K	0.295	0.311	7.500	7.900
C	0.571	0.587	14.500	14.900	L	0.042	0.054	1.050	1.350
D	0.028	0.035	0.700	0.900	M	0.017	0.023	0.430	0.580
E	0.020	0.028	0.500	0.700	N	0.118	REF	3.000	REF
F	0.091	TYP	2.300	TYP	S	0.197	REF	5.000	REF
G	0.091	TYP	2.300	TYP	T	0.150	REF	3.800	REF
H	0.017	0.023	0.430	0.580	U	0.055	REF	1.400	REF
I	0.087	0.094	2.200	2.400					

Notes: 1.Controlling dimension: millimeters.
 2.Maximum lead thickness includes lead finish thickness, and minimum lead thickness is the minimum thickness of base material.
 3.If there is any question with packing specification or packing method, please contact your local CYStek sales office.

Material:

- Lead: Pure tin plated
- Mold Compound: Epoxy resin family, flammability solid burning class: UL94V-0

Important Notice:

- All rights are reserved. Reproduction in whole or in part is prohibited without the prior written approval of CYStek.
- CYStek reserves the right to make changes to its products without notice.
- CYStek **semiconductor products are not warranted to be suitable for use in Life-Support Applications, or systems.**
- CYStek assumes no liability for any consequence of customer product design, infringement of patents, or application assistance.