

ATLANTIC VERSION TERMINATOR INTERFACE ADAPTER	PART NUMBER	REVISION	DESCRIPTION	FEED TYPE	APPLICATOR STYLE CONVERSION CHART						
					CONVERT TO	PART NUMBERS REQUIRED					
	2151542-1	A	FINE CRIMP HEIGHT ADJUST	MECHANICAL	PNEUMATIC FEED	2119950-1	1338683-9	5-18022-5	2119641-1	2119799-1	2063440-1
					SERVO LATCH PLATE	2119951-1	-	8-2151542-5	1901094-3	-	2168400-6 (QUANTITY 2)
					SMART APPLICATOR	2161326-1	-	8-2151542-4	-	-	-
	2151542-2	A	FINE CRIMP HEIGHT ADJUST	PNEUMATIC	MECHANICAL FEED	2119949-1	1338683-9	5-18022-5	2119653-1	-	-
					SERVO LATCH PLATE	2119951-1	-	8-2151542-5	1901094-3	-	2168400-6 (QUANTITY 2)
					SMART APPLICATOR	2161326-1	-	8-2151542-4	-	-	-
	2151542-5	A	FINE CRIMP HEIGHT ADJUST	SERVO LATCH PLATE	MECHANICAL FEED	2119949-1	1338683-9	5-18022-5	2119653-1	-	-
PNEUMATIC FEED					2119950-1	1338683-9	5-18022-5	2119641-1	2119799-1	2063440-1	
2151542-6	A	NON-CRIMP HEIGHT ADJUST	SERVO LATCH PLATE	-	-	-	-	-	-	-	
2151542-7	A	FINE CRIMP HEIGHT ADJUST	NONE	-	-	-	-	-	-	-	
7-2151542-7	A	CRIMP TOOLING KIT	-	-	-	-	-	-	-	-	

APPLICATOR DATA		
CRIMP	SIZE	TYPE
WIRE	3.05 mm [.120]	F
INSUL	-	-

APPLICATOR INSTRUCTIONS
408-10389

TERMINAL DATA: TE TERMINAL		TE CONNECTIVITY CRIMP SPEC	
TERMINAL NAME: CONTACT, AMP POWER SERIES 15			
WIRE STRIP LENGTH		INSULATION DIAMETER RANGE	-
4.30-6.48 mm [.169-.255 IN]			
TERMINAL APPLICATION SPECIFICATION		114-13127 Rev B	-
TERMINALS APPLIED			
TE TERMINAL	TE TERMINAL	TE TERMINAL	TE TERMINAL
1604113-1	1604113-2	-	-

WIRE SIZE	CRIMP HEIGHT mm [INCH]	CRIMP HEIGHT REFERENCE SETTING
16 AWG	1.75+/-0.05 [.069+/- .002]	6.6
18 AWG	1.63+/-0.05 [.064+/- .002]	7.8
20 AWG	1.50+/-0.05 [.059+/- .002]	9.1

- RECOMMENDED SPARE PARTS
- GREASE BEARING SURFACES LIGHTLY
- 3. LUBRICATE DAILY PER THE APPLICATOR INSTRUCTION SHEET SUPPLIED WITH THE APPLICATOR.
- APPLICATOR SPECIFIC DATA TO BE ENTERED INTO BLANK MEMORY CHIP AT ASSEMBLY. SEE BELOW FOR PART NUMBER:
 MECHANICAL FEED WITH "SMART APPLICATOR" CONVERSION: 8-2151542-4
 PNEUMATIC FEED WITH "SMART APPLICATOR" CONVERSION: 8-2151542-4
 SERVO FEED WITH "FINE CRIMP HEIGHT ADJUST": 8-2151542-5
 SERVO FEED WITH "NON-CRIMP HEIGHT ADJUST": 8-2151542-6
- 5. ADJUSTMENT OF THE STRIPPER MAY BE REQUIRED WHEN MOVING THE APPLICATOR BETWEEN BENCH AND LEADMAKER APPLICATIONS.
- APPLY PART NUMBER 1-23419-5 LOCTITE TO THREADS OF ITEMS 50, 62. FOR -6 ONLY APPLY PART NUMBER 1-23419-5 LOCTITE TO THREADS OF ITEMS 37, 50.
- GREASE THREADS, GROOVE AND O-RING ON ITEMS 35 & 252.
- MAGNET, ITEM 166 MUST BE ORIENTED CORRECTLY IN ORDER TO PROPERLY ACTUATE THE COUNTER.
- CRIMP HEIGHT REFERENCE SETTING WAS THE SETTING USED WHEN THE APPLICATOR WAS QUALIFIED AT THE FACTORY. ADJUSTMENT MAY BE NECESSARY WHEN RUNNING APPLICATOR IN THE FIELD.
- SPARE FEED CAM STORAGE LOCATION REFER TO INSTRUCTION SHEET FOR ADDITIONAL INFORMATION.
- WHEN ASSEMBLING -6 NON-CRIMP HEIGHT ADJUST APPLICATOR USE SHIM PACK 2119957-2 TO ALIGN APPLICATOR'S MAXIMUM WIRE CRIMP HEIGHT AT NORMAL TERMINATOR SHUT HEIGHT

***WARNING**
ON INSTALLATION, SET WIRE DISC, ITEM 40 TO LARGEST WIRE SIZE SETTING. USE OF SETTINGS BELOW MINIMUM REQUIRED CRIMP HEIGHT SETTING WILL CAUSE DAMAGE TO CRIMP TOOLING.

ATLANTIC VERSION
Shown on sheets 1 of 4 & 2 of 4
(Pacific version shown on sheets 3 of 4 & 4 of 4)

SET UP GAUGE	LOC	DIST	REVISIONS			
2119599-1	A	66	REV	DATE	BY	APPV
-	-	-	A	RELEASED	24MAR2012	RW

-	-	1	-	-	-	2119957-2	APPLICATOR SHIM PACK	260
-	1	-	1	1	1	8-21084-0	O-RING, .676 ID, .070 DIA. MAT.	252
-	-	-	-	1	-	2119640-1	PUSH ROD, AIR FEED	250
-	-	-	-	1	-	2079988-1	BUSHING, LCH5-12, MISUMI	249
-	-	-	-	1	-	2119641-1	FEED CAM, AIR FEED	248
-	1	-	1	1	1	2119798-1	DETENT PIN	247
-	1	-	1	1	1	1-22279-3	SPRING, COMPRESSION	246
-	-	1	-	-	-	2119758-1	RAM, AMP STYLE, SIDE FEED, NON-ADJ.	245
-	-	2	2	-	-	2168400-6	SHCS, LOW HEAD, RoHS, M5 X 16	240
-	-	-	-	-	1	2119580-1	MECHANICAL FEED ASSEMBLY	239
-	-	-	-	1	-	2063440-1	AIR FEED MODULE	238
-	-	1	1	-	-	2119740-2	TAG, IDENTIFICATION	213
-	-	1	1	-	-	1901094-3	SPACER, FEEDER	198
-	-	-	-	2	-	21045-3	RING, RETAIN, EXTERN, 3/16 CRESCENT	172
-	1	1	1	1	1	994969-1	MAGNET, RARE EARTH HIGH ENERGY	166
-	REF	REF	REF	REF	REF	994970-2	COUNTER, MAGNETIC	164
-	-	-	-	1	-	240638-1	SPRING, FEED FINGER	163
-	-	-	-	1	-	3-23627-7	PIN, RETAIN, GRVD, 3/16 X .854	137
-	-	-	-	1	-	2119799-1	HOLDER, FEED FINGER, AF	136
-	-	REF	REF	-	-	SEE NOTE 4	MEMORY CHIP, PROGRAMMED	135
-	-	1	1	-	-	1633743-1	SERVO FEED LATCH ASM	133
-	1	1	1	1	1	1-22281-8	SPRING, COMPRESSION	121
-	-	REF	REF	-	-	2119944-1	FEED FINGER ASSEMBLY, SF	117
-	1	1	1	1	1	1-690712-7	FRONT STRIP GUIDE	115
-	1	1	1	1	1	980371-4	SCR, SKT HD SHLDR 5.0 DIA X 6.0	100
	1	1	1	1	1	2168083-3	SCR, SKT HD CAP, RoHS, M4 X 12.0	98
-	2	2	2	2	2	1-2168083-0	SCR, SKT HD CAP, RoHS, M4 X 10	98
-	2	2	2	2	2	4-18024-4	SCR, BTN SKT HD CAP (M4 X 6.0)	97
-	1	1	1	1	1	1633055-1	GUIDE, STOCK	94
-	1	1	1	1	1	2168083-6	SCR, SKT HD CAP, RoHS, M5 X 65	93
-	2	2	2	2	2	2-18032-5	SCR, SET, FLT POINT M5 X 20.0	91
-	2	2	2	2	2	2168083-1	SCR, SKT HD CAP, RoHS, M3 X 8.0	85
-	1	1	1	1	1	1-455888-2	SPACER, CRIMPER	82
-	2	2	2	2	2	2079383-2	SCR, BHSC, RoHS (M3 X 10)	79
-	1	1	1	1	1	1-2119928-7	FENCE	78
-	1	1	1	1	1	2119956-1	DOCUMENTATION PACKAGE	71
-	1	-	-	1	1	2119740-1	TAG, IDENTIFICATION	67
-	2	2	2	2	2	2168078-1	SCREW, DRIVE, RH, RoHS, 2 x .188	66
-	1	-	1	1	1	2119793-1	LIMITER, ADJUSTMENT BOLT	63
-	3	-	3	3	3	992763-5	SCR, SET, SOC, CONE POINT, M3 X 4.0	62
-	1	1	1	1	1	2079383-4	SCR, BHSC, RoHS (M4 X 8)	60
	-	-	-	1	1	5-18022-5	SCR, HEX HD CAP, M4 X 6.0	59
-	-	-	-	1	1	1338683-9	FEED PAWL	56
-	2	2	2	2	2	2168083-8	SCR, SKT HD CAP, RoHS, M4 X 16	53
-	1	1	1	1	1	2-18031-1	SCR, SET, CUP POINT M3 X 3.0	52
	1	1	1	1	1	1-811242-0	BUMPER, HOLD DOWN	51
	1	1	1	1	1	1-1803011-2	HOLDER, SLUG BLADE	50
-	-	-	-	1	2	18023-9	SCR, SKT HD CAP M4 X 6.0	49
-	-	-	-	-	1	2119652-1	FEED CAM, PRE FEED	48
-	-	-	-	-	1	2119653-1	FEED CAM, POST FEED	47
-	1	1	1	1	1	2119656-1	APPLICATOR BASIC ASSEMBLY, SF	46
-	1	-	1	1	1	2119370-1	RAM, AMP STYLE, SIDE FEED	44
-	1	1	1	1	1	2079383-7	SCR, BHSC, RoHS (M8 X 25)	41
-	1	-	1	1	1	2119645-1	DISC, NUMBERED FA WIRE ADJUSTMENT	40
-	1	-	1	1	1	2119957-1	APPLICATOR SHIM PACK	39
	1	1	1	1	1	2119644-2	RAM WASHER, PRECISION	38
	1	1	1	1	1	2119085-1	FA HEAD, ATLANTIC STYLE	37
-	1	-	1	1	1	2119092-1	BOLT, ADJUSTMENT	35
-	2	2	2	2	2	2079383-8	SCR, BHSC, RoHS (M4 X 16)	33
-	1	1	1	1	1	2161328-1	HEX HEAD, FLANGED, M5 X 8mm LONG	32
-	1	1	1	1	1	1-1320908-1	SPACER, STRIP GUIDE	30
-	1	1	1	1	1	1-1901086-9	PLATE, STRIP GUIDE	29
-	2	2	2	2	2	22283-1	SPRING, COMPRESSION	27
-	1	1	1	1	1	356835-1	LEVER, DRAG RELEASE	26
-	1	1	1	1	1	6-690754-6	DRAG, SPECIAL	25
-	1	1	1	1	1	1803053-7	STRIP GUIDE, REAR	23
	1	1	1	1	1	2168083-8	SCR, SKT HD CAP, RoHS, M4 X 16	21
	1	1	1	1	1	1-18028-2	WASHER, FLAT, REG M4	20
	1	1	1	1	1	2119533-1	STRIPPER, SIDE FEED	19
	1	1	1	1	1	1633579-5	BLADE, SLUG	10
	1	1	1	1	1	2-1803012-4	PLATE, REAR SHEAR	9
	1	1	1	1	1	1803050-4	ANVIL, SPECIAL, COMBINATION	8
	1	1	1	1	1	2-456409-3	CRIMPER, WIRE .120 "F" PREMIUM	1

DIMENSIONS:		TOLERANCES UNLESS OTHERWISE SPECIFIED:		DRAWN		CHK		APPV		NAME	
mm	0 PLC ±.5	1 PLC ±.5	2 PLC ±.5	3 PLC ±.5	4 PLC ±.5	R. O. WILSON	16MAR2012	K. J. STAKEM	19MAR2012	TE Connectivity	Harrisburg, PA 17105-3608
	ANGLES ±.0001	FINISH				T. ELBRIN	19MAR2012			Ocean Side Feed	Applicator
MATERIAL										SIZE	CAGE CODE
										A1	00779
										Customer Accessible Production Drawing	SCALE
										1:2	SHEET
										1	OF
										4	REV
										A	

LOC		DIST		REVISIONS			
A	66	P	LTM	DESCRIPTION	DATE	OWN	APVD
		-	-	SEE SHEET 1	-	-	-

FEED TYPE MECHANICAL

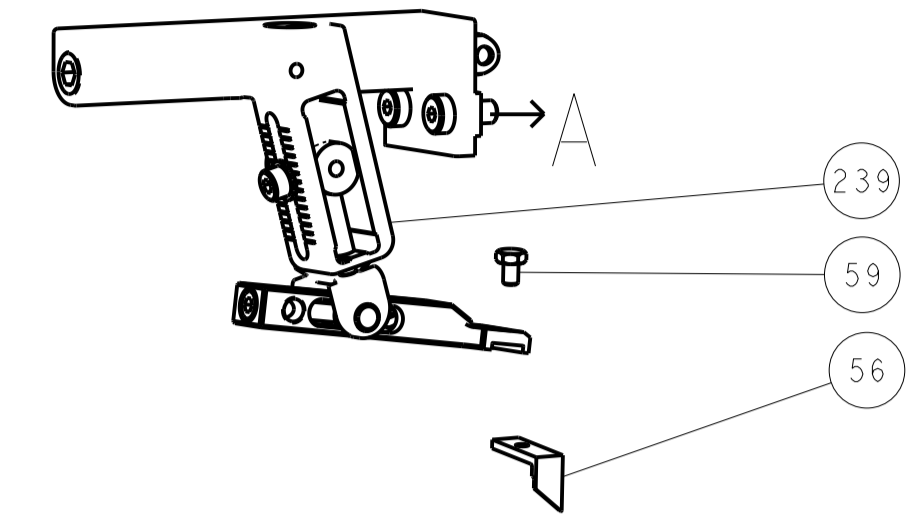

PNEUMATIC

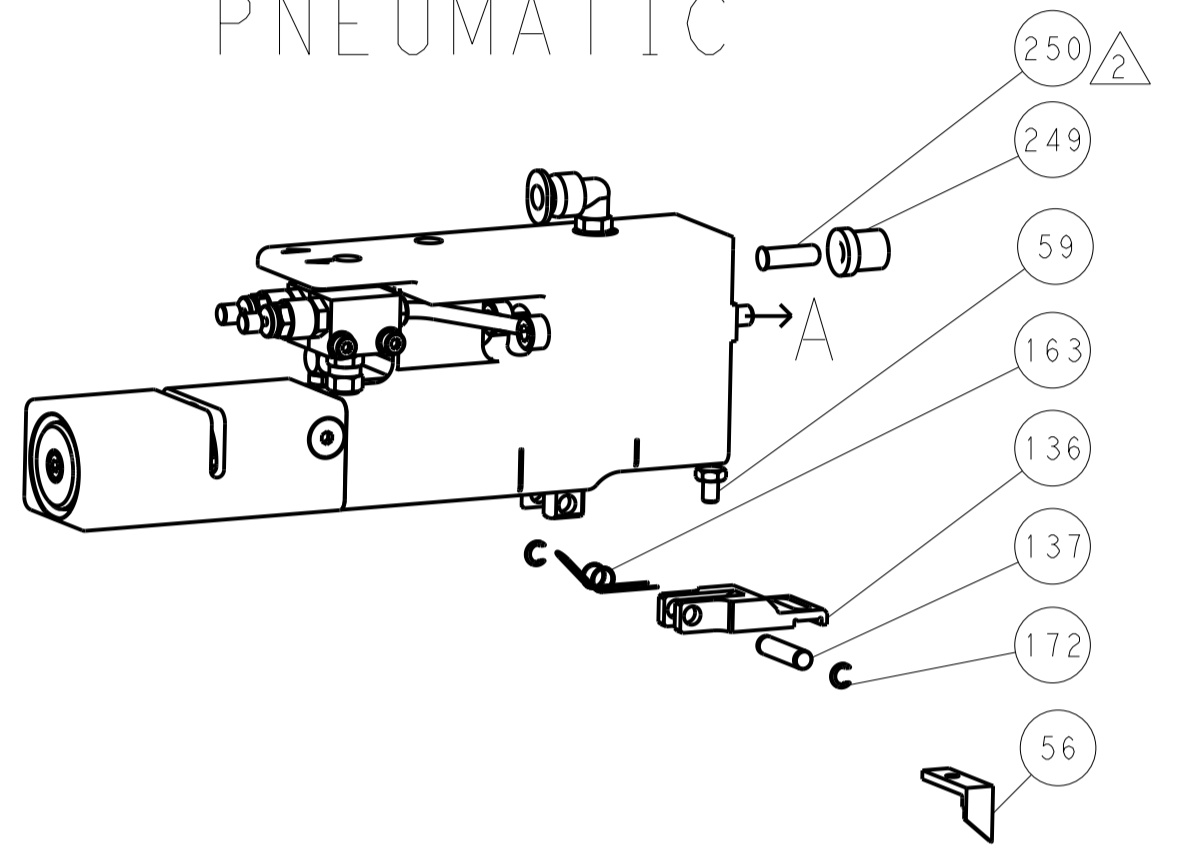

SERVO LATCH PLATE

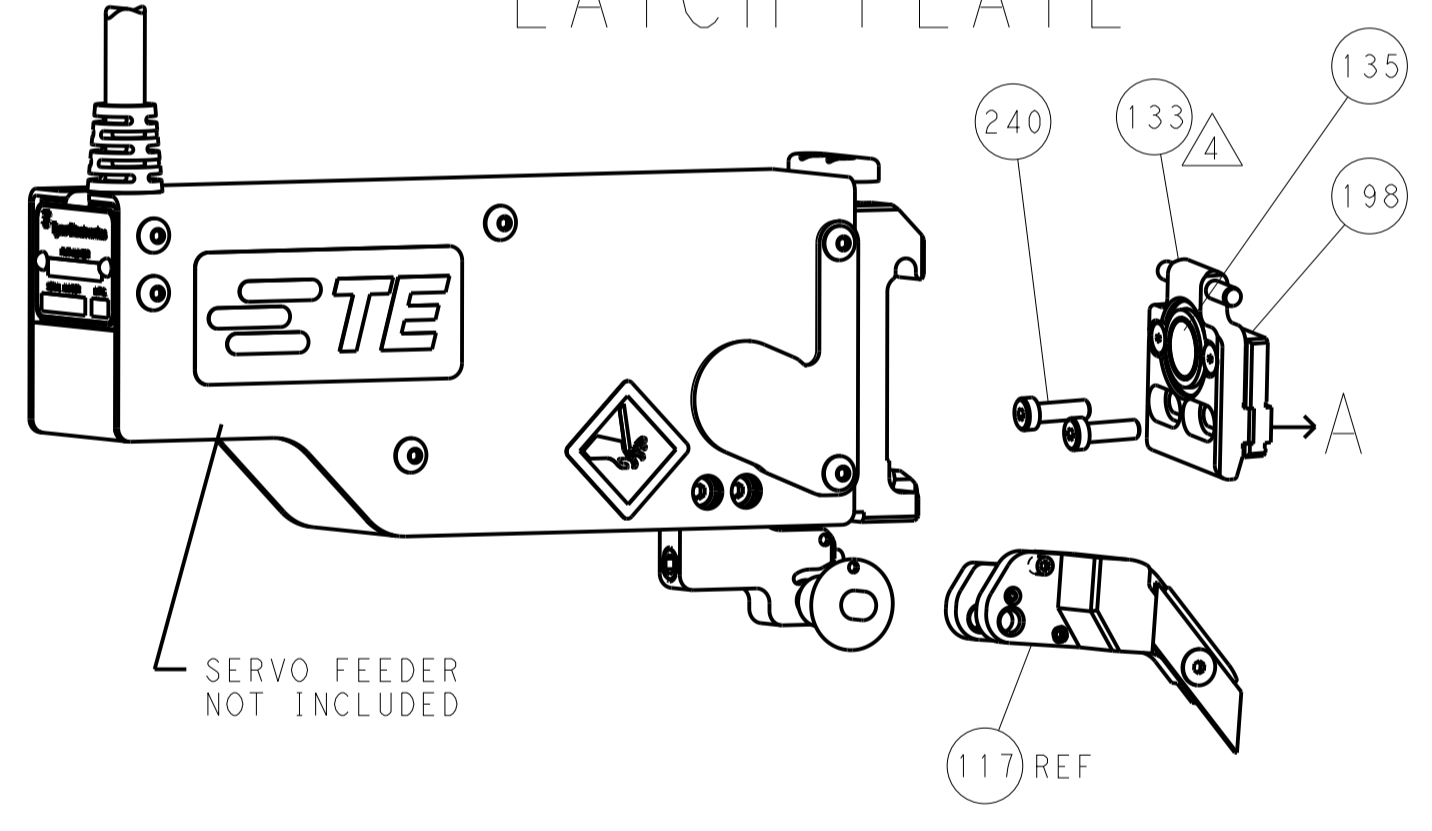

CAM POSITIONS

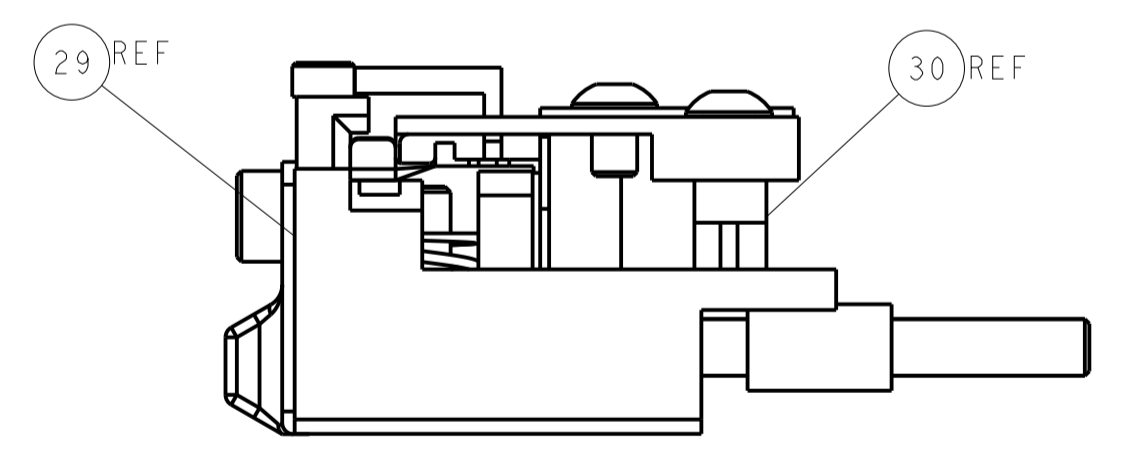
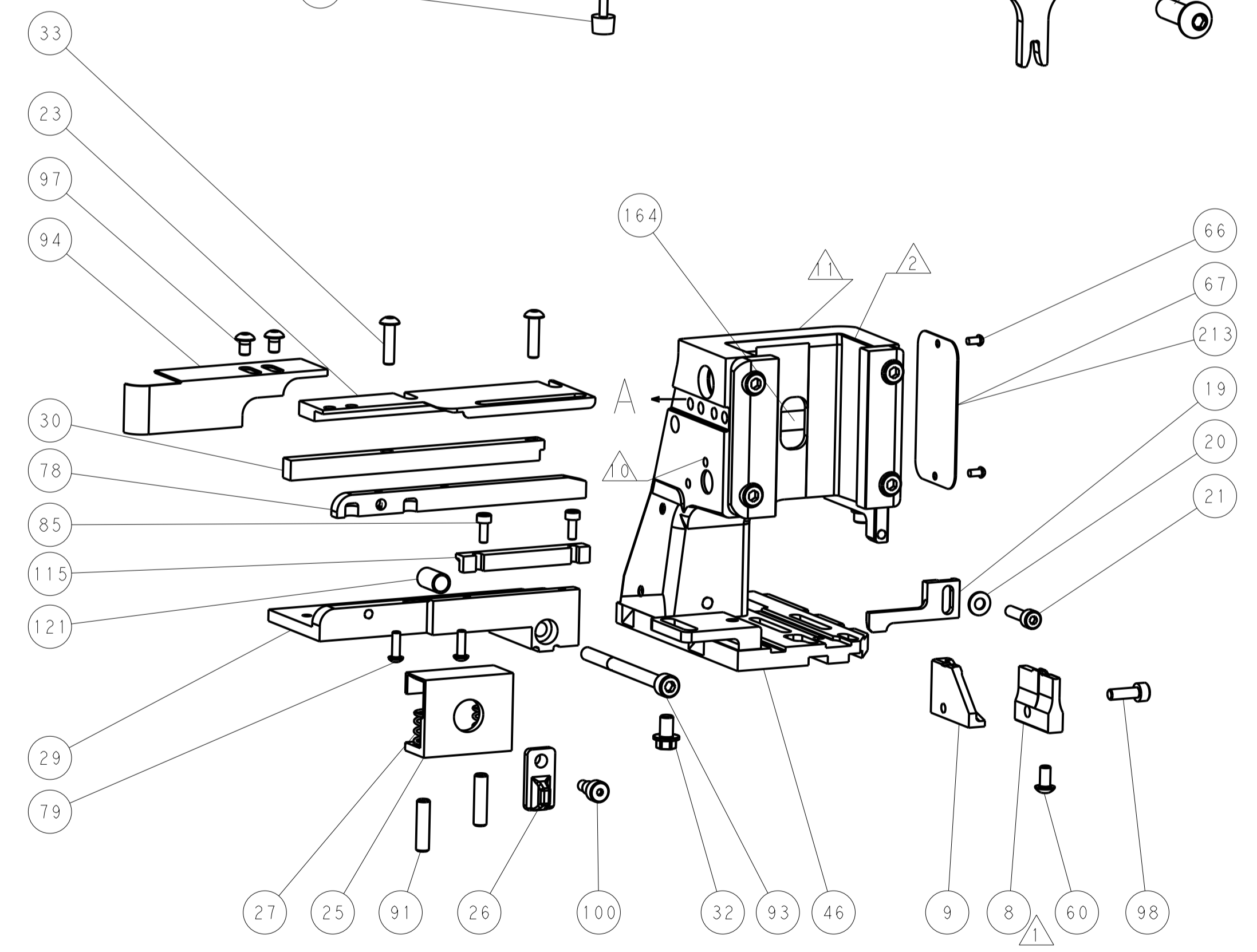
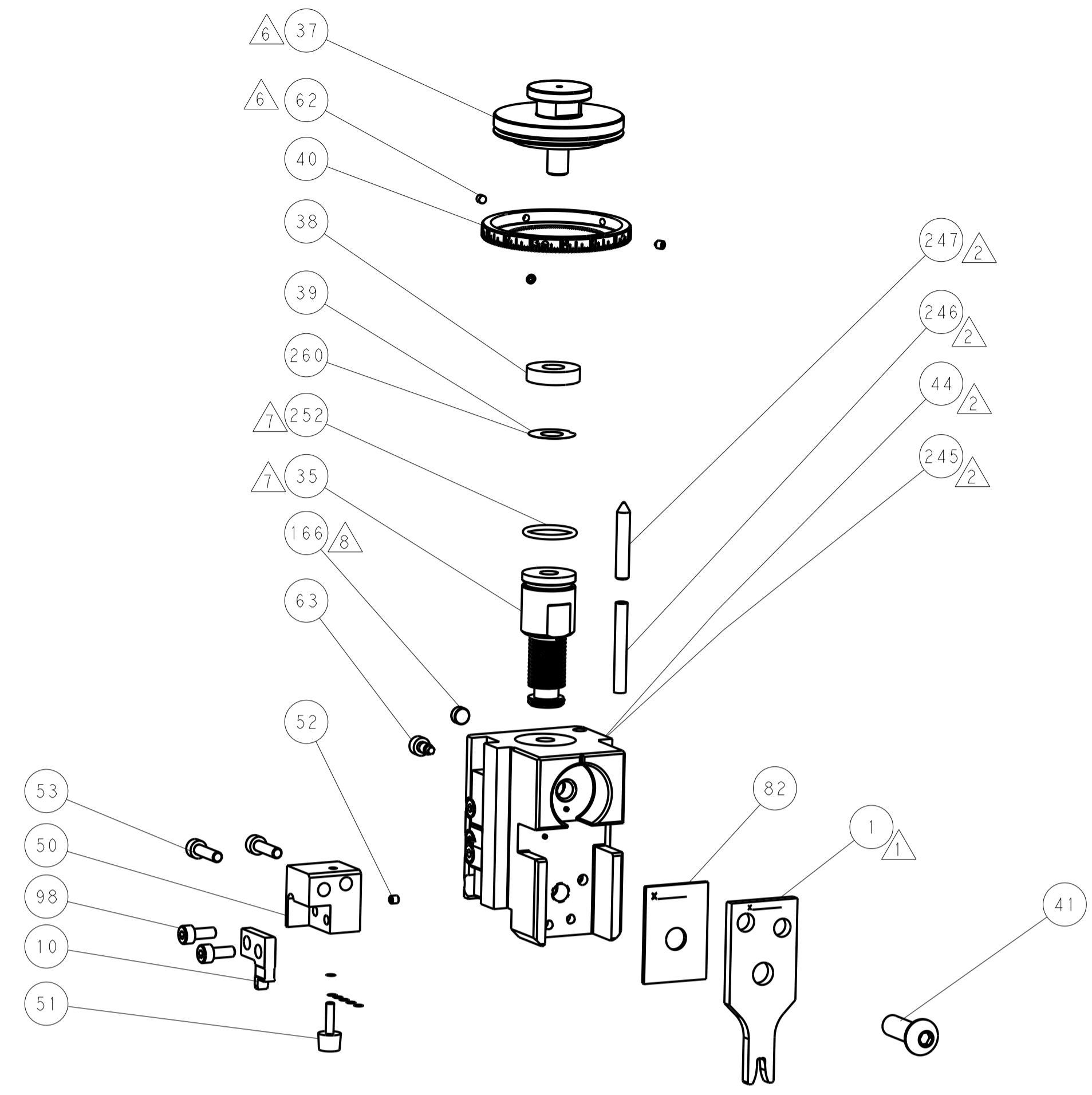
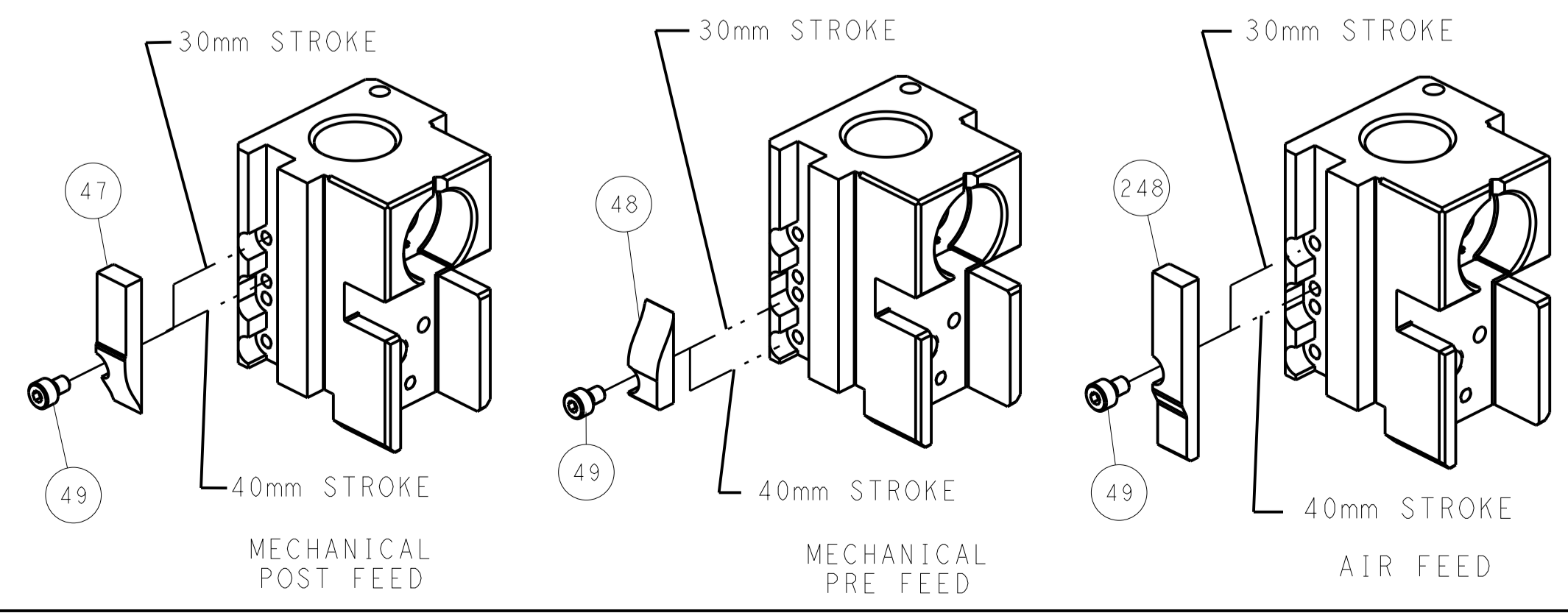

ITEM 30 LOCATED AT FRONT HOLES

FEED TRACK POSITION GUIDE BY INSULATION AND BODY

ATLANTIC VERSION
 Shown on sheets 1 of 4 & 2 of 4
 (Pacific version shown on sheets 3 of 4 & 4 of 4)

DIMENSIONS:		TOLERANCES UNLESS OTHERWISE SPECIFIED:		DWG: R.O. WILSON 16MAR2012		TE Connectivity	
mm	0 PLC ±0.5	1 PLC ±0.5	2 PLC ±0.13	3 PLC ±0.013	4 PLC ±0.0013	APVD: T.L. ELFIN 19MAR2012	Harrisburg, PA 17105-3608
MATERIAL:		FINISH:		NAME: Ocean Side Feed Applicator		RESTRICTED TO:	
				SIZE: A11 00779 C=2151542		SCALE: 1:2 SHEET 2 OF 4 REV A	

PACIFIC VERSION TERMINATOR INTERFACE ADAPTER	PART NUMBER	REVISION	DESCRIPTION	FEED TYPE	APPLICATOR STYLE CONVERSION CHART						
					CONVERT TO	PART NUMBERS REQUIRED					
	2-2151542-1	A	FINE CRIMP HEIGHT ADJUST	MECHANICAL	PNEUMATIC FEED	2119950-1	1338683-9	5-18022-5	2119641-2	2119799-1	2063440-1
					SERVO LATCH PLATE	2119951-1	-	8-2151542-5	1901094-3	-	2168400-6 (QUANTITY 2)
					SMART APPLICATOR	2161326-1	-	8-2151542-4	-	-	-
	2-2151542-2	A	FINE CRIMP HEIGHT ADJUST	PNEUMATIC	MECHANICAL FEED	2119949-1	1338683-9	5-18022-5	2119653-2	-	-
					SERVO LATCH PLATE	2119951-1	-	8-2151542-5	1901094-3	-	2168400-6 (QUANTITY 2)
					SMART APPLICATOR	2161326-1	-	8-2151542-4	-	-	-
	2-2151542-5	A	FINE CRIMP HEIGHT ADJUST	SERVO LATCH PLATE ⁴	MECHANICAL FEED	2119949-1	1338683-9	5-18022-5	2119653-2	-	-
					PNEUMATIC FEED	2119950-1	1338683-9	5-18022-5	2119641-2	2119799-1	2063440-1
	2-2151542-7	A	FINE CRIMP HEIGHT ADJUST	NONE	-	-	-	-	-	-	-
	7-2151542-7	A	CRIMP TOOLING KIT	-	-	-	-	-	-	-	-

APPLICATOR DATA		
CRIMP	SIZE	TYPE
WIRE	3.05 mm [1.201]	F
INSUL	-	-
APPLICATOR INSTRUCTIONS 408-10389		

TERMINAL DATA: TE TERMINAL		TE CONNECTIVITY CRIMP SPEC
TERMINAL NAME: CONTACT, AMP POWER SERIES 15		
WIRE STRIP LENGTH		INSULATION DIAMETER RANGE
4.30-6.48 mm [1.69-.255 IN]		
TERMINAL APPLICATION SPECIFICATION	114-13127 Rev B	
TERMINALS APPLIED		
TE TERMINAL	TE TERMINAL	TE TERMINAL
1604113-1	1604113-2	

WIRE SIZE	CRIMP HEIGHT mm [INCH]	CRIMP HEIGHT REFERENCE SETTING
16 AWG	1.75 +/- 0.05 [1.069 +/- .002]	6.6
18 AWG	1.63 +/- 0.05 [1.064 +/- .002]	7.8
20 AWG	1.50 +/- 0.05 [1.059 +/- .002]	9.1

- RECOMMENDED SPARE PARTS
- GREASE BEARING SURFACES LIGHTLY
- 3. LUBRICATE DAILY PER THE APPLICATOR INSTRUCTION SHEET SUPPLIED WITH THE APPLICATOR.
- APPLICATOR SPECIFIC DATA TO BE ENTERED INTO BLANK MEMORY CHIP AT ASSEMBLY. SEE BELOW FOR PART NUMBER:
 MECHANICAL FEED WITH "SMART APPLICATOR" CONVERSION: 8-2151542-4
 PNEUMATIC FEED WITH "SMART APPLICATOR" CONVERSION: 8-2151542-4
 SERVO FEED WITH "FINE CRIMP HEIGHT ADJUST": 8-2151542-5
- 5. ADJUSTMENT OF THE STRIPPER MAY BE REQUIRED WHEN MOVING THE APPLICATOR BETWEEN BENCH AND LEADMAKER APPLICATIONS.
- APPLY PART NUMBER 1-23419-5 LOCTITE TO THREADS OF ITEM 50 & 62.
- GREASE THREADS, GROOVE AND O-RING ON ITEMS 139 & 152.
- MAGNET MUST BE ORIENTED CORRECTLY IN ORDER TO PROPERLY ACTUATE THE COUNTER.
- CRIMP HEIGHT REFERENCE SETTING WAS THE SETTING USED WHEN THE APPLICATOR WAS QUALIFIED AT THE FACTORY. ADJUSTMENT MAY BE NECESSARY WHEN RUNNING APPLICATOR IN THE FIELD.
- SPARE FEED CAM STORAGE LOCATION REFER TO INSTRUCTION SHEET FOR ADDITIONAL INFORMATION.
- TO CONVERT THE APPLICATOR TO A NON-CARRIER CUTTING STYLE, REMOVE ITEM 13 AND ATTACH TO THE LOCATION ON BACK SIDE OF THE HOUSING. REFER TO INSTRUCTION SHEET FOR ADDITIONAL INFORMATION.

***WARNING**
 ON INSTALLATION, SET WIRE DISC, ITEM 40 TO LARGEST WIRE SIZE SETTING. USE OF SETTINGS BELOW MINIMUM REQUIRED CRIMP HEIGHT SETTING WILL CAUSE DAMAGE TO CRIMP TOOLING.

PACIFIC VERSION
 Shown on sheets 3 of 4 & 4 of 4
 (Atlantic version shown on sheets 1 of 4 & 2 of 4)

SET UP GAUGE	LOC	DIST	REVISIONS			
2119599-1	A	66	REV	DATE	BY	APPD
			-	SEE SHEET 1	-	-

-	1	1	1	1	2119782-1	FINE ADJUST HEAD ASM, PACIFIC STYLE	251
-	-	-	1	-	2119640-1	PUSH ROD, AIR FEED	250
-	-	-	1	-	2079988-1	BUSHING, LCH5-12, MISUMI	249
-	1	1	1	1	1-22279-3	SPRING, COMPRESSION	246
-	-	2	-	-	2168400-6	SHCS, LOW HEAD, RoHS, M5 X 16	240
-	-	-	-	1	2119580-1	MECHANICAL FEED ASSEMBLY	239
-	-	-	1	-	2063440-1	AIR FEED MODULE	238
-	-	1	-	-	2119740-2	TAG IDENTIFICATION	213
-	-	1	-	-	1901094-3	SPACER, FEEDER	198
-	-	2	-	-	21045-3	RING, RETAIN, EXTERN, 3/16 CRESCENT	172
-	1	1	1	1	994969-1	MAGNET, RARE EARTH HIGH ENERGY	166
-	REF	REF	REF	REF	994970-2	COUNTER, MAGNETIC	164
-	-	-	1	-	240638-1	SPRING, FEED FINGER	163
-	1	1	1	1	8-21084-1	O-RING, .801 ID, .070 DIA. MAT.	152
-	-	-	1	-	2119641-2	FEED CAM, AIR FEED	151
-	1	1	1	1	2119798-2	DETENT PIN	145
-	1	1	1	1	2079383-8	SCR, BHSC, RoHS (M4 X 16)	144
-	-	-	-	1	2119653-2	FEED CAM, POST FEED	142
-	1	1	1	1	2119656-2	APPLICATOR BASIC ASSEMBLY, SF	141
-	1	1	1	1	2119650-1	RAM, ASIAN STYLE, SIDE FEED	140
-	1	1	1	1	2119092-2	BOLT, ADJUSTMENT	139
-	-	-	1	-	3-23627-7	PIN, RETAIN, GRVD, 3/16 X .854	137
-	-	-	1	-	2119799-1	HOLDER, FEED FINGER, AF	136
-	-	REF	-	-	SEE NOTE 4	MEMORY CHIP, PROGRAMMED	135
-	-	1	-	-	1633743-1	SERVO FEED LATCH ASM	133
-	1	1	1	1	1-22281-8	SPRING, COMPRESSION	121
-	-	REF	-	-	2119944-1	FEED FINGER ASSEMBLY, SF	117
-	1	1	1	1	1-690712-7	FRONT STRIP GUIDE	115
-	1	1	1	1	980371-4	SCR, SKT HD SHLDR 5.0 DIA X 6.0	100
⁴	-	1	1	1	2168083-3	SCR, SKT HD CAP, RoHS, M4 X 12.0	98
-	2	2	2	2	1-2168083-0	SCR, SKT HD CAP, RoHS, M4 X 10	98
-	2	2	2	2	4-18024-4	SCR, BTN SKT HD CAP (M4 X 6.0)	97
-	1	1	1	1	1633055-1	GUIDE, STOCK	94
-	1	1	1	1	2168083-6	SCR, SKT HD CAP, RoHS, M5 X 65	93
-	2	2	2	2	2-18032-5	SCR, SET, FLT POINT M5 X 20.0	91
-	2	2	2	2	2168083-1	SCR, SKT HD CAP, RoHS, M3 X 8.0	85
-	1	1	1	1	1-455888-2	SPACER, CRIMPER	82
-	2	2	2	2	2079383-2	SCR, BHSC, RoHS (M3 X 10)	79
-	1	1	1	1	1-2119928-7	FENCE	78
-	1	1	1	1	2119956-1	DOCUMENTATION PACKAGE	71
-	1	-	1	1	2119740-1	TAG IDENTIFICATION	67
-	2	2	2	2	2168078-1	SCREW, DRIVE, RH, RoHS, 2 x .188	66
-	1	1	1	1	2119793-1	LIMITER, ADJUSTMENT BOLT	63
-	3	3	3	3	992763-5	SCR, SET, SOC, CONE POINT, M3 x 4.0	62
-	-	-	1	1	5-18022-5	SCR, HEX HD CAP, M4 X 6.0	59
⁶	-	-	-	1	1338683-9	FEED PAWL	56
-	2	2	2	2	2168083-8	SCR, SKT HD CAP, RoHS, M4 X 16	53
-	1	1	1	1	2-18031-1	SCR, SET, CUP POINT M3 X 3.0	52
-	1	1	1	1	1-811242-0	BUMPER, HOLD DOWN	51
⁶	-	1	1	1	1-1803011-2	HOLDER, SLUG BLADE	50
-	-	-	1	2	18023-9	SCR, SKT HD CAP M4 X 6.0	49
-	-	-	-	1	2119652-1	FEED CAM, PRE FEED	48
-	1	1	1	1	2079383-7	SCR, BHSC, RoHS (M8 X 25)	41
-	1	1	1	1	2119645-1	DISC, NUMBERED FA WIRE ADJUSTMENT	40
-	1	1	1	1	2119957-1	APPLICATOR SHIM PACK	39
-	1	1	1	1	2119644-2	RAM WASHER, PRECISION	38
-	2	2	2	2	2079383-8	SCR, BHSC, RoHS (M4 X 16)	33
-	1	1	1	1	2161328-1	HEX HEAD, FLANGED, M5 x 8mm LONG	32
-	1	1	1	1	1-1320908-1	SPACER, STRIP GUIDE	30
-	1	1	1	1	1-1901086-9	PLATE, STRIP GUIDE	29
-	2	2	2	2	22283-1	SPRING, COMPRESSION	27
-	1	1	1	1	356835-1	LEVER, DRAG RELEASE	26
-	1	1	1	1	6-690754-6	DRAG, SPECIAL	25
-	1	1	1	1	1803053-7	STRIP GUIDE, REAR	23
¹	-	1	1	1	2168083-8	SCR, SKT HD CAP, RoHS, M4 X 16	21
¹	-	1	1	1	1-18028-2	WASHER, FLAT, REG M4	20
¹	-	1	1	1	2119533-1	STRIPPER, SIDE FEED	19
¹	-	1	1	1	1633579-5	BLADE, SLUG	10
¹	-	1	1	1	2-1803012-4	PLATE, REAR SHEAR	9
1	1	1	1	1	1803050-4	ANVIL, SPECIAL, COMBINATION	8
1	1	1	1	1	2-456409-3	CRIMPER, WIRE .120 "F" PREMIUM	1
-77	-27	-25	-22	-21	PART NO	DESCRIPTION	ITEM NO

DIMENSIONS:		TOLERANCES UNLESS OTHERWISE SPECIFIED:		OWN	CHK	DATE	REV
mm	0 PLC ±.5	1 PLC ±.5	2 PLC ±.5	R. O. WILSON	K. J. STAKEM	16MAR2012	19MAR2012
	3 PLC ±.5	4 PLC ±.5	ANGLES ±.0001				
MATERIAL:		FINISH:		NAME		TE Connectivity Harrisburg, PA 17105-3608	
				Ocean Side Feed Applicator			
				SIZE		CAGE CODE DRAWING NO	
				A1		00779 C=2151542	
				WEIGHT		SCALE	
				Customer Accessible Production Drawing		1:2 SHEET 3 OF 4 REV A	

LOC		DIST		REVISIONS			
A	66	P	LTM	DESCRIPTION	DATE	DWN	APVD
		-	-	SEE SHEET 1	-	-	-

FEED TYPE MECHANICAL

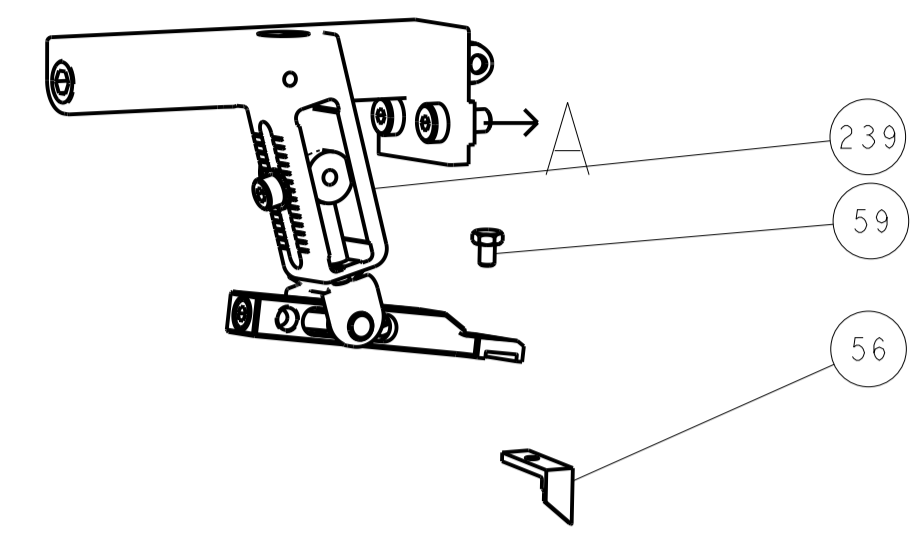

PNEUMATIC

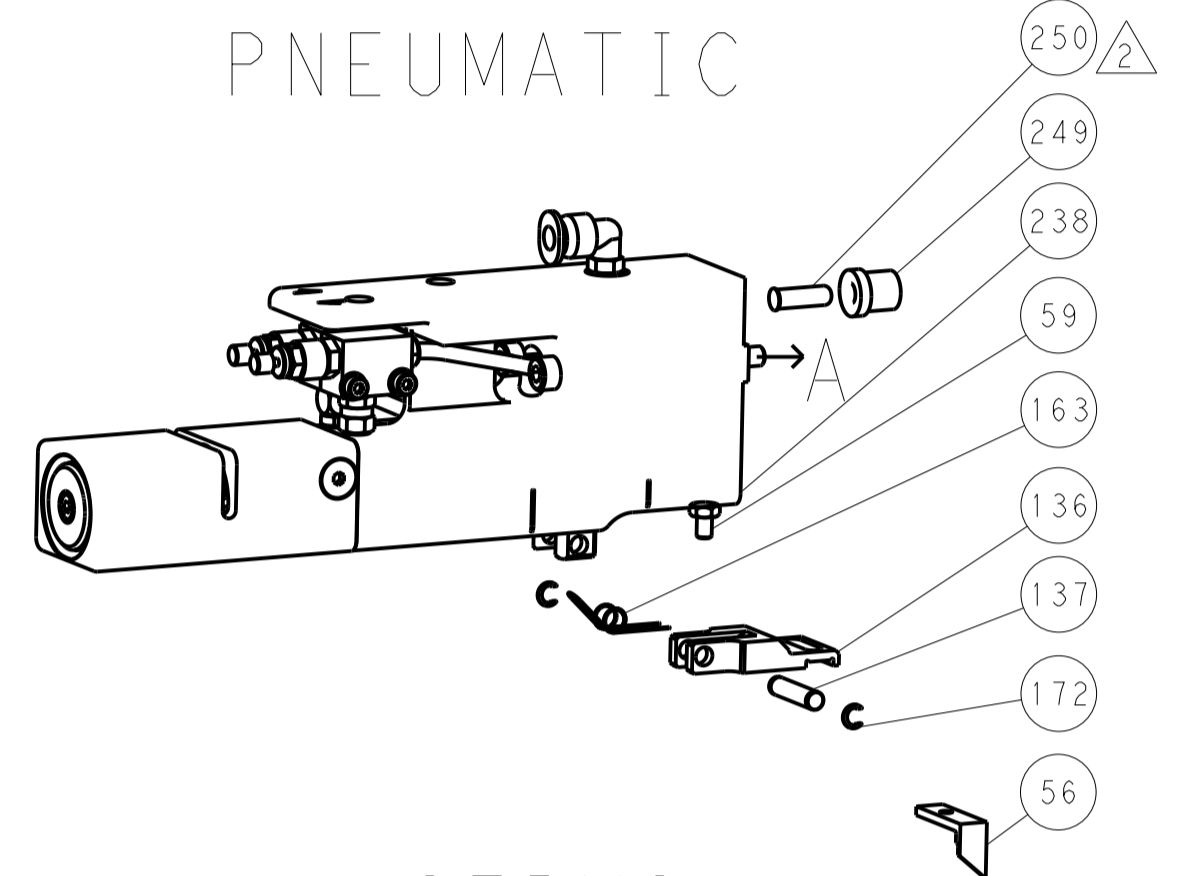

SERVO LATCH PLATE

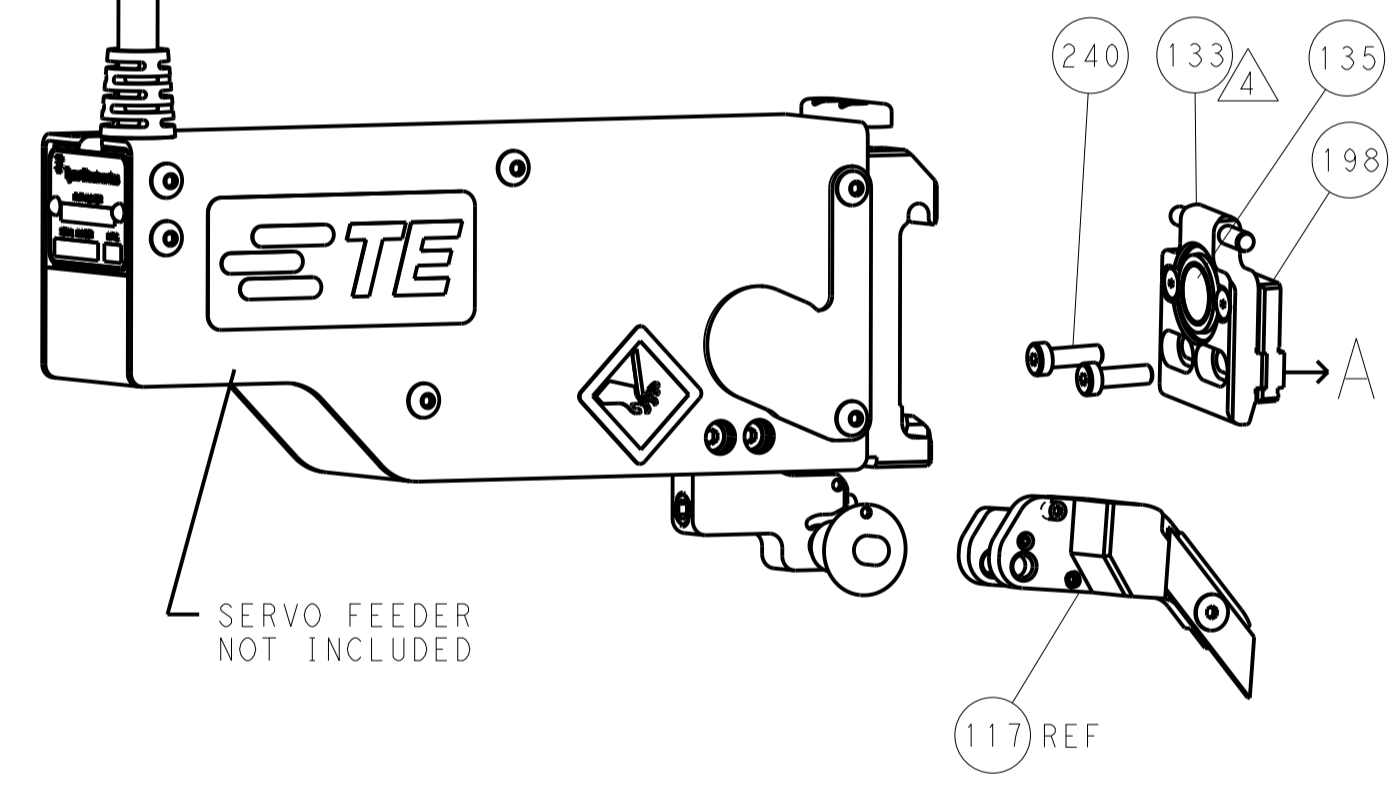

CAM POSITIONS

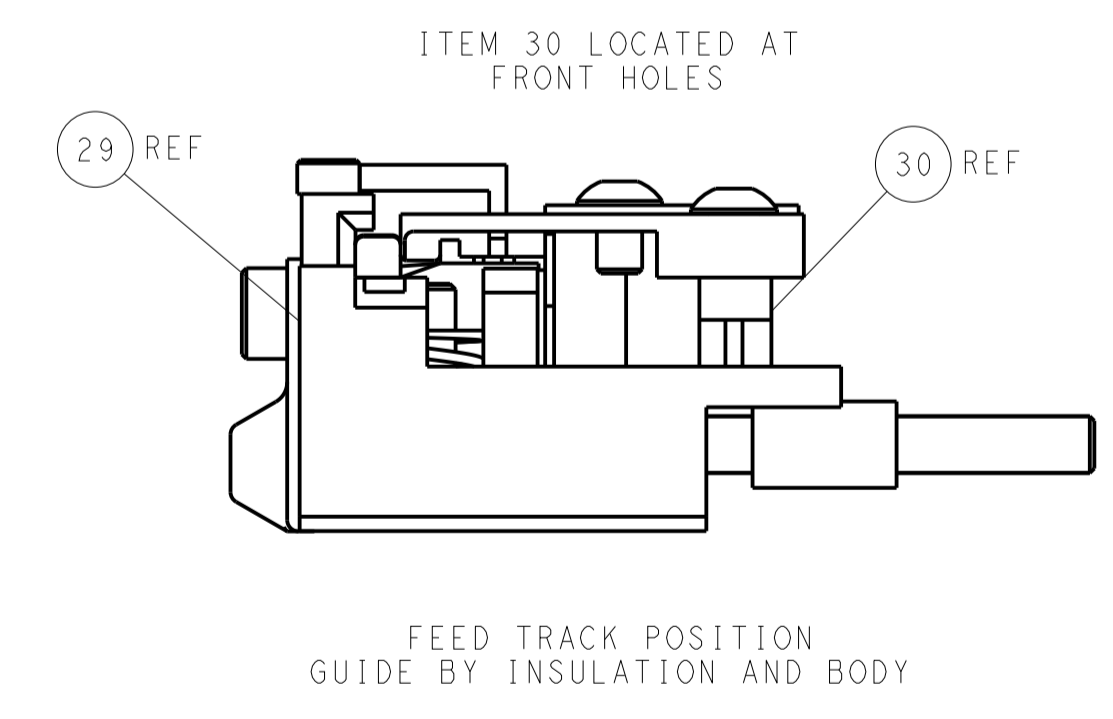
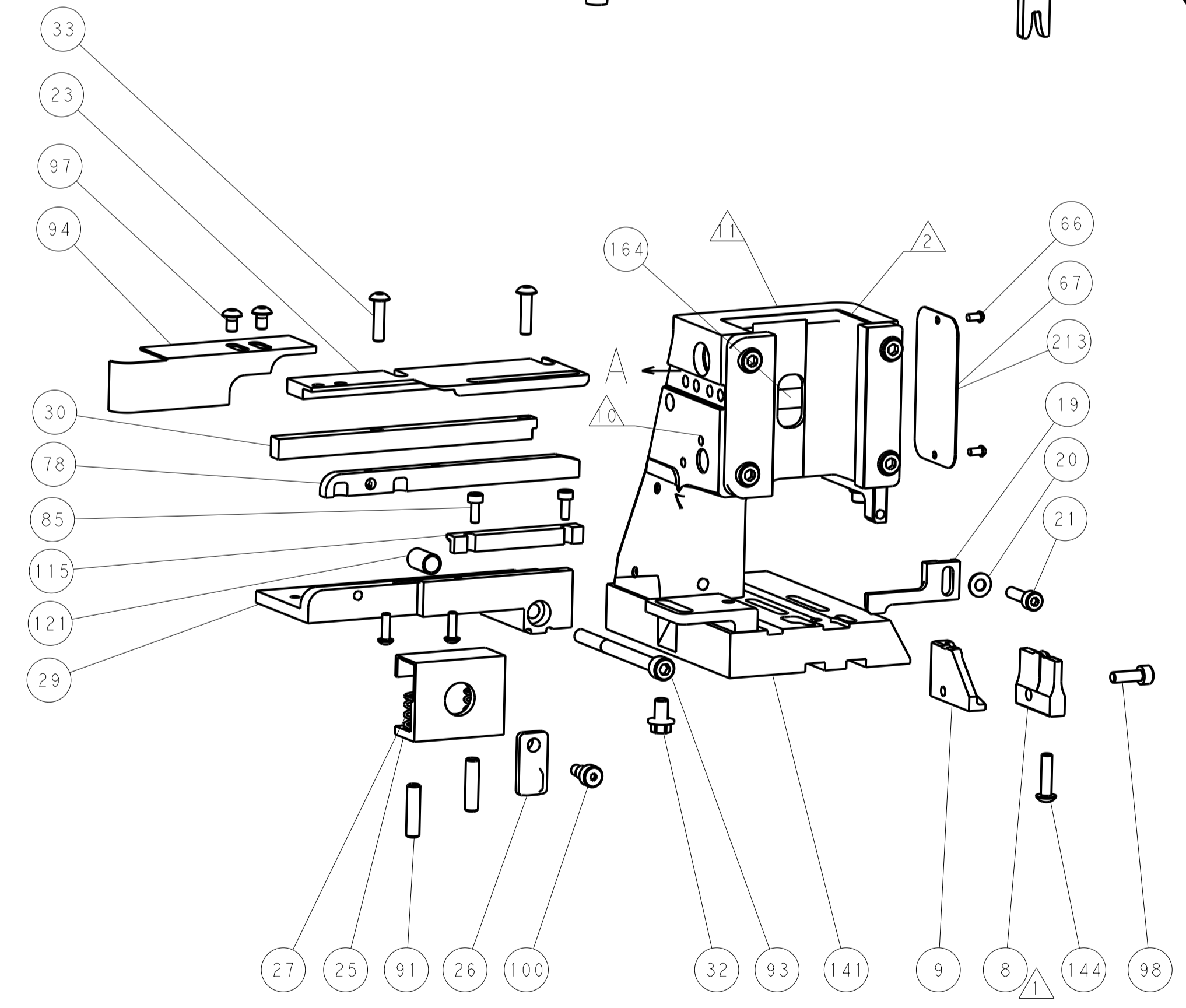
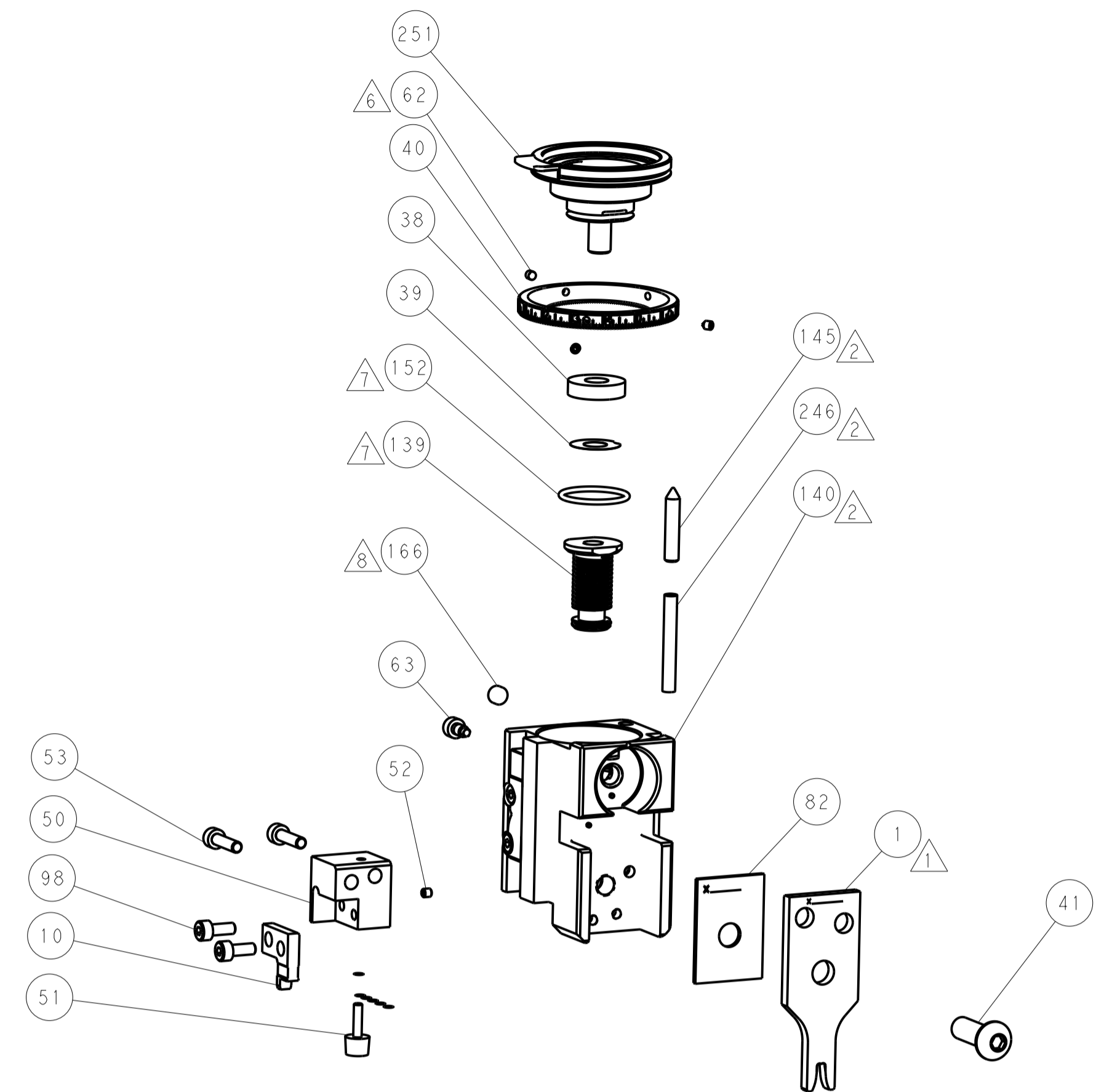
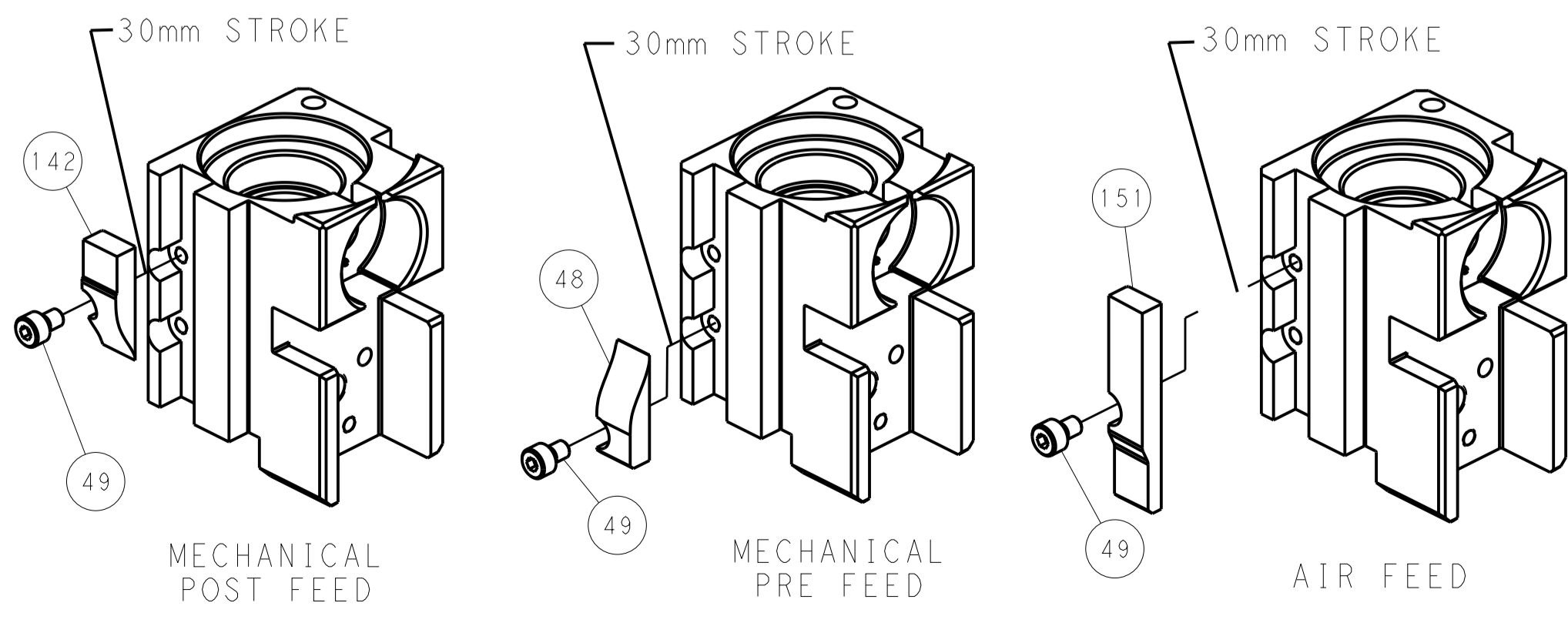

PACIFIC VERSION
 Shown on sheets 3 of 4 & 4 of 4
 (Atlantic version shown on sheets 1 of 4 & 2 of 4)

DIMENSIONS:		TOLERANCES UNLESS OTHERWISE SPECIFIED:		DWN R.O. WILSON 16MAR2012		TE Connectivity	
mm	0 PLC ±0.5	1 PLC ±0.5	2 PLC ±0.13	3 PLC ±0.013	CHK K.J. STAKEM 19MAR2012	Harrisburg, PA 17105-3608	
	4 PLC ±0.001	FINISH		APVD T.L. ELFIN 19MAR2012	NAME Ocean Side Feed Applicator		
MATERIAL		WEIGHT		SIZE CAGE CODE DRAWING NO		RESTRICTED TO	
				A 00779 C=2151542		Customer Accessible Production Drawing	
				SCALE	1:2	SHEET	4 of 4
				REV	A		