

# EFM32 Pearl Gecko Family

## EFM32PG1 Data Sheet



The EFM32 Pearl Gecko MCUs are the world's most energy-friendly microcontrollers.

EFM32PG1 features a powerful 32-bit ARM<sup>®</sup> Cortex<sup>®</sup>-M4 and a wide selection of peripherals, including a unique cryptographic hardware engine supporting AES, ECC, and SHA. These features, combined with ultra-low current active mode and short wake-up time from energy-saving modes, make EFM32PG1 microcontrollers well suited for any battery-powered application, as well as other systems requiring high performance and low-energy consumption.

Example applications:

- IoT devices and sensors
- Health and fitness
- Smart accessories
- Home automation and security
- Industrial and factory automation

### ENERGY FRIENDLY FEATURES

- ARM Cortex-M4 at 40 MHz
- Ultra low energy operation:
  - 1.1  $\mu$ A EM3 Stop current (CRYOTIMER running with state/RAM retention)
  - 1.4  $\mu$ A EM2 DeepSleep current (RTCC running with state and RAM retention)
  - 60  $\mu$ A/MHz in Energy Mode 0 (EM0)
- Hardware cryptographic engine supports AES, ECC, and SHA
- Integrated dc-dc converter
- CRYOTIMER operates down to EM4
- 5 V tolerant I/O

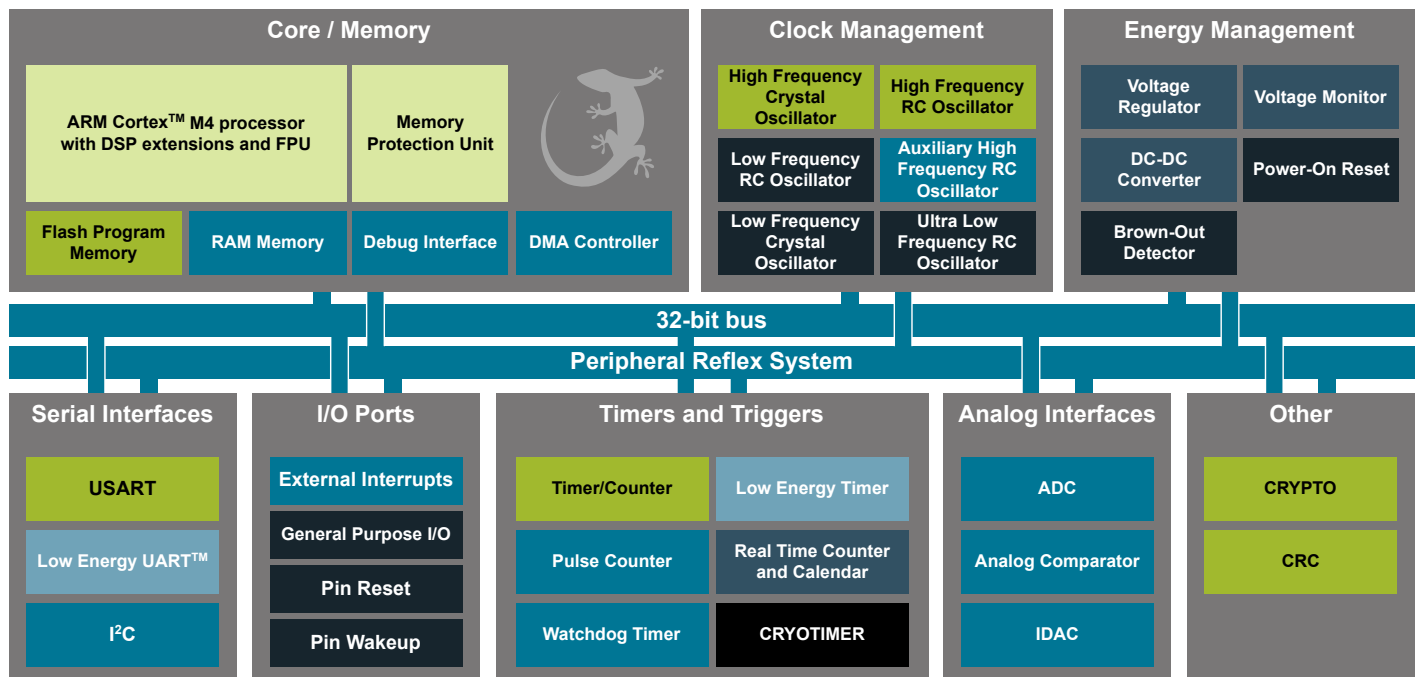

Lowest power mode with peripheral operational:



## 1. Feature List

The EFM32PG1 highlighted features are listed below.

- **ARM Cortex-M4 CPU platform**
  - High Performance 32-bit processor @ up to 40 MHz
  - Wake-up Interrupt Controller
- **Flexible Energy Management System**
  - 60  $\mu$ A/MHz in Energy Mode 0 (EM0)
  - 1.4  $\mu$ A EM2 DeepSleep current (RTCC running with state and RAM retention)
  - 1.1  $\mu$ A EM3 Stop current (CRYOTIMER running with state/RAM retention)
- **Up to 256 kB flash program memory**
- **32 kB RAM data memory**
- **Up to 32 General Purpose I/O Pins**
  - Configurable push-pull, open-drain, pull-up/down, input filter, drive strength
  - Configurable peripheral I/O locations
  - Asynchronous external interrupts
  - Output state retention and wake-up from Shutoff Mode
- **Hardware Cryptography**
  - AES 128/256-bit keys
  - ECC B/K163, B/K233, P192, P224, P256
  - SHA-1 and SHA-2 (SHA-224 and SHA-256)
- **Timers/Counters**
  - 2 $\times$  16-bit Timer/Counter
    - 3 + 4 Compare/Capture/PWM channels
  - 1 $\times$  32-bit Real Time Counter and Calendar
  - 1 $\times$  32-bit Ultra Low Energy CRYOTIMER for periodic wake-up from any Energy Mode
  - 16-bit Low Energy Timer for waveform generation
  - 16-bit Pulse Counter with asynchronous operation
  - Watchdog Timer with dedicated RC oscillator @ 50 nA
- **8 Channel DMA Controller**
- **12 Channel Peripheral Reflex System (PRS) for autonomous inter-peripheral signaling**
- **Communication Interfaces**
  - 2 $\times$  Universal Synchronous/Asynchronous Receiver/ Transmitter
    - UART/SPI/SmartCard (ISO 7816)/IrDA/I2S/LIN
    - Triple buffered full/half-duplex operation with flow control
  - Low Energy UART
    - Autonomous operation with DMA in Deep Sleep Mode
  - I<sup>2</sup>C Interface with SMBus support
    - Address recognition in EM3 Stop Mode
- **Ultra Low-Power Precision Analog Peripherals**
  - 12-bit 1 Msamples/s Analog to Digital Converter
  - 2 $\times$  Analog Comparator
  - Digital to Analog Current Converter
  - Up to 24 pins connected to analog channels (APORT) shared between Analog Comparators, ADC, and IDAC
- **Ultra efficient Power-on Reset and Brown-Out Detector**
- **Debug Interface**
  - 2-pin Serial Wire Debug interface
  - 1-pin Serial Wire Viewer
  - JTAG (programming only)
- **Pre-Programmed UART Bootloader**
- **Wide Operating Range**
  - 1.85 V to 3.8 V single power supply
  - Integrated dc-dc, down to 1.8 V output with up to 200 mA load current for system
  - Temperature range -40 to 85  $^{\circ}$ C
- **Packages**
  - 7 mm  $\times$  7 mm QFN48
  - 5 mm  $\times$  5 mm QFN32

## 2. Ordering Information

Ordering Code	Flash (KB)	RAM (KB)	DC-DC Converter	GPIO	Package
EFM32PG1B200F256GM48-B0*	256	32	Yes	32	QFN48
EFM32PG1B200F128GM48-B0*	128	32	Yes	32	QFN48
EFM32PG1B200F256GM32-B0*	256	32	Yes	20	QFN32
EFM32PG1B200F128GM32-B0*	128	32	Yes	20	QFN32
EFM32PG1B100F256GM32-B0*	256	32	No	24	QFN32
EFM32PG1B100F128GM32-B0*	128	32	No	24	QFN32

\* Engineering Samples

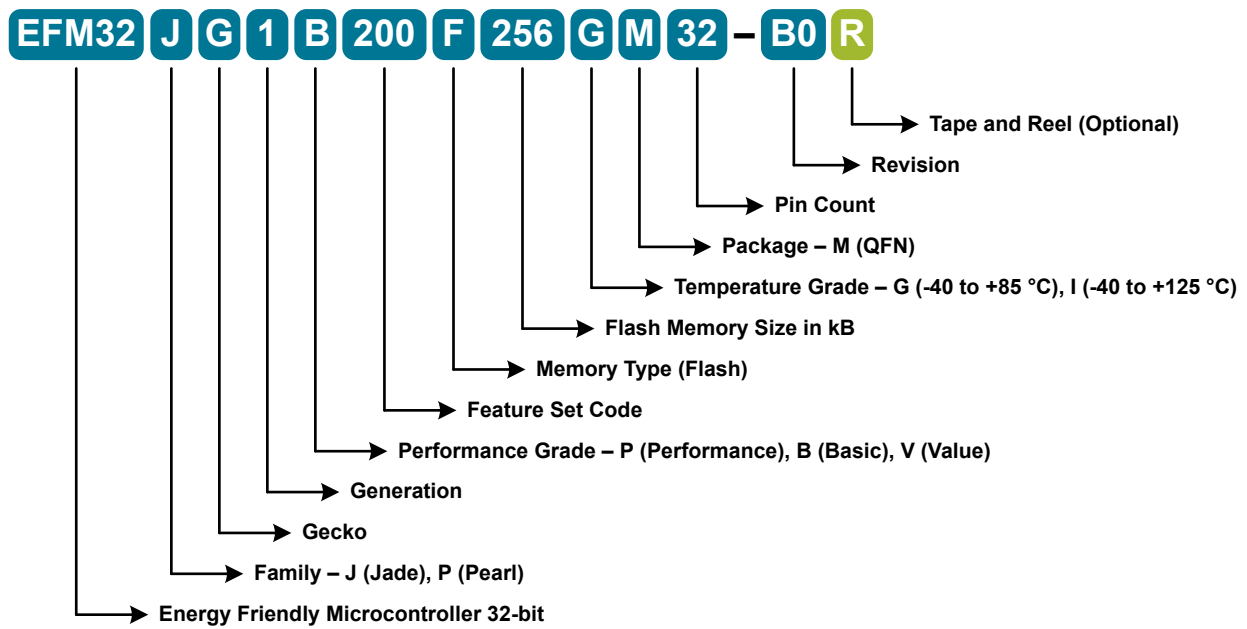

Figure 2.1. OPN Decoder

### 3. System Overview

#### 3.1 Introduction

The EFM32PG1 product family is well suited for any battery operated application as well as other systems requiring high performance and low energy consumption. This section gives a short introduction to the MCU system. The detailed functional description can be found in the EFM32PG1 Reference Manual.

A block diagram of the EFM32PG1 family is shown in [Figure 3.1 Detailed EFM32PG1 Block Diagram on page 3](#). The diagram shows a superset of features available on the family, which vary by OPN. For more information about specific device features, consult [Ordering Information](#).

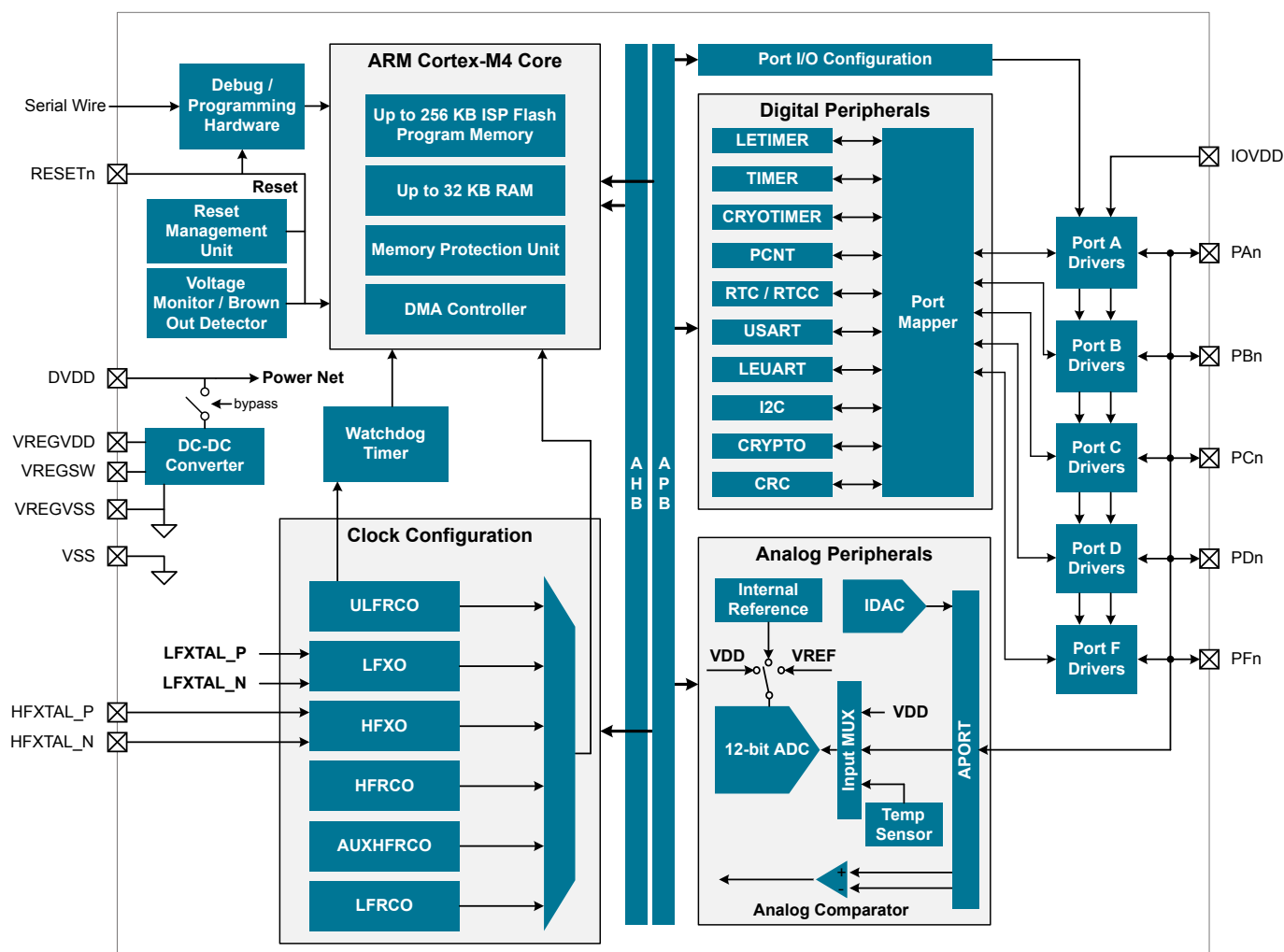

Figure 3.1. Detailed EFM32PG1 Block Diagram

## 3.2 Power

The EFM32PG1 has an Energy Management Unit (EMU) and efficient integrated regulators to generate internal supply voltages. Only a single external supply voltage is required, from which all internal voltages are created. An optional integrated dc-dc buck regulator can be utilized to further reduce the current consumption. The dc-dc regulator requires one external inductor and one external capacitor.

AVDD and VREGVDD need to be 1.85 V or higher for the MCU to operate across all conditions; however the rest of the system will operate down to 1.62 V, including the digital supply and I/O. This means that the device is fully compatible with 1.8 V components. Running from a sufficiently high supply, the device can use the dc-dc to regulate voltage not only for itself, but also for other PCB components, supplying up to a total of 200 mA.

### 3.2.1 Energy Management Unit (EMU)

The Energy Management Unit manages transitions of energy modes in the device. Each energy mode defines which peripherals and features are available and the amount of current the device consumes. The EMU can also be used to turn off the power to unused RAM blocks, and it contains control registers for the dc-dc regulator and the Voltage Monitor (VMON). The VMON is used to monitor multiple supply voltages. It has multiple channels which can be programmed individually by the user to determine if a sensed supply has fallen below a chosen threshold.

### 3.2.2 DC-DC Converter

The dc-dc buck converter covers a wide range of load currents and provides up to 90% efficiency in energy modes EM0, EM1, EM2 and EM3, and can supply up to 200 mA to the device and surrounding PCB components. Protection features include programmable current limiting, short-circuit protection, and dead-time protection. The dc-dc converter may also enter bypass mode when the input voltage is too low for efficient operation. In bypass mode, the dc-dc input supply is internally connected directly to its output through a low resistance switch. Bypass mode also supports in-rush current limiting to avoid dipping the input supply due to excessive current transients.

## 3.3 General Purpose Input/Output (GPIO)

EFM32PG1 has up to 32 General Purpose Input/Output pins. Each GPIO pin can be individually configured as either an output or input. More advanced configurations including open-drain, open-source, and glitch-filtering can be configured for each individual GPIO pin. The GPIO pins can be overridden by peripheral connections, like SPI communication. Each peripheral connection can be routed to several GPIO pins on the device. The input value of a GPIO pin can be routed through the Peripheral Reflex System to other peripherals. The GPIO subsystem supports asynchronous external pin interrupts.

## 3.4 Clocking

### 3.4.1 Clock Management Unit (CMU)

The Clock Management Unit controls oscillators and clocks in the EFM32PG1. Individual enabling and disabling of clocks to all peripheral modules is performed by the CMU. The CMU also controls enabling and configuration of the oscillators. A high degree of flexibility allows software to optimize energy consumption in any specific application by minimizing power dissipation in unused peripherals and oscillators.

### 3.4.2 Internal and External Oscillators

The EFM32PG1 supports two crystal oscillators and fully integrates four RC oscillators, listed below.

- A high frequency crystal oscillator (HFXO) with integrated load capacitors, tunable in small steps, provides a precise timing reference for the MCU. Crystal frequencies in the range from 38 to 40 MHz are supported. An external clock source such as a TCXO can also be applied to the HFXO input for improved accuracy over temperature.
- A 32.768 kHz crystal oscillator (LFXO) provides an accurate timing reference for low energy modes.
- An integrated high frequency RC oscillator (HFRCO) is available for the MCU system, when crystal accuracy is not required. The HFRCO employs fast startup at minimal energy consumption combined with a wide frequency range.
- An integrated auxiliary high frequency RC oscillator (AUXHFRCO) is available for timing the general-purpose ADC and the Serial Wire debug port with a wide frequency range.
- An integrated low frequency 32.768 kHz RC oscillator (LFRCO) can be used as a timing reference in low energy modes, when crystal accuracy is not required.
- An integrated ultra-low frequency 1 kHz RC oscillator (ULFRCO) is available to provide a timing reference at the lowest energy consumption in low energy modes.

## 3.5 Counters/Timers and PWM

### 3.5.1 Timer/Counter (TIMER)

TIMER peripherals keep track of timing, count events, generate PWM outputs and trigger timed actions in other peripherals through the PRS system. The core of each TIMER is a 16-bit counter with up to 4 compare/capture channels. Each channel is configurable in one of three modes. In capture mode, the counter state is stored in a buffer at a selected input event. In compare mode, the channel output reflects the comparison of the counter to a programmed threshold value. In PWM mode, the TIMER supports generation of pulse-width modulation (PWM) outputs of arbitrary waveforms defined by the sequence of values written to the compare registers, with optional dead-time insertion available in timer unit TIMER\_0 only.

### 3.5.2 Real Time Counter and Calendar (RTCC)

The Real Time Counter and Calendar (RTCC) is a 32-bit counter providing timekeeping in all energy modes. The RTCC includes a Binary Coded Decimal (BCD) calendar mode for easy time and date keeping. The RTCC can be clocked by any of the on-board oscillators with the exception of the AUXHFRCO, and it is capable of providing system wake-up at user defined instances. When receiving frames, the RTCC value can be used for timestamping. The RTCC includes 128 bytes of general purpose data retention, allowing easy and convenient data storage in all energy modes.

### 3.5.3 Low Energy Timer (LETIMER)

The unique LETIMER is a 16-bit timer that is available in energy mode EM2 Deep Sleep in addition to EM1 Sleep and EM0 Active. This allows it to be used for timing and output generation when most of the device is powered down, allowing simple tasks to be performed while the power consumption of the system is kept at an absolute minimum. The LETIMER can be used to output a variety of waveforms with minimal software intervention. The LETIMER is connected to the Real Time Counter and Calendar (RTCC), and can be configured to start counting on compare matches from the RTCC.

### 3.5.4 Ultra Low Power Wake-up Timer (CRYOTIMER)

The CRYOTIMER is a 32-bit counter that is capable of running in all energy modes. It can be clocked by either the 32.768 kHz crystal oscillator (LFXO), the 32.768 kHz RC oscillator (LFRCO), or the 1 kHz RC oscillator (ULFRCO). It can provide periodic Wakeup events and PRS signals which can be used to wake up peripherals from any energy mode. The CRYOTIMER provides a wide range of interrupt periods, facilitating flexible ultra-low energy operation.

### 3.5.5 Pulse Counter (PCNT)

The Pulse Counter (PCNT) peripheral can be used for counting pulses on a single input or to decode quadrature encoded inputs. The clock for PCNT is selectable from either an external source on pin PCTNn\_S0IN or from an internal timing reference, selectable from among any of the internal oscillators, except the AUXHFRCO. The module may operate in energy mode EM0 Active, EM1 Sleep, EM2 Deep Sleep, and EM3 Stop.

### 3.5.6 Watchdog Timer (WDOG)

The watchdog timer can act both as an independent watchdog or as a watchdog synchronous with the CPU clock. It has windowed monitoring capabilities, and can generate a reset or different interrupts depending on the failure mode of the system. The watchdog can also monitor autonomous systems driven by PRS.

## 3.6 Communications and Other Digital Peripherals

### 3.6.1 Universal Synchronous/Asynchronous Receiver/Transmitter (USART)

The Universal Synchronous/Asynchronous Receiver/Transmitter is a flexible serial I/O module. It supports full duplex asynchronous UART communication with hardware flow control as well as RS-485, SPI, MicroWire and 3-wire. It can also interface with devices supporting:

- ISO7816 SmartCards
- IrDA
- I<sup>2</sup>S

### 3.6.2 Low Energy Universal Asynchronous Receiver/Transmitter (LEUART)

The unique LEUART™ provides two-way UART communication on a strict power budget. Only a 32.768 kHz clock is needed to allow UART communication up to 9600 baud. The LEUART includes all necessary hardware to make asynchronous serial communication possible with a minimum of software intervention and energy consumption.

### 3.6.3 Inter-Integrated Circuit Interface (I<sup>2</sup>C)

The I<sup>2</sup>C module provides an interface between the MCU and a serial I<sup>2</sup>C bus. It is capable of acting as both a master and a slave and supports multi-master buses. Standard-mode, fast-mode and fast-mode plus speeds are supported, allowing transmission rates from 10 kbit/s up to 1 Mbit/s. Slave arbitration and timeouts are also available, allowing implementation of an SMBus-compliant system. The interface provided to software by the I<sup>2</sup>C module allows precise timing control of the transmission process and highly automated transfers. Automatic recognition of slave addresses is provided in active and low energy modes.

### 3.6.4 Peripheral Reflex System (PRS)

The Peripheral Reflex System provides a communication network between different peripheral modules without software involvement. Peripheral modules producing Reflex signals are called producers. The PRS routes Reflex signals from producers to consumer peripherals which in turn perform actions in response. Edge triggers and other functionality can be applied by the PRS. The PRS allows peripheral to act autonomously without waking the MCU core, saving power.

## 3.7 Security Features

### 3.7.1 GPCRC (General Purpose Cyclic Redundancy Check)

The GPCRC module implements a Cyclic Redundancy Check (CRC) function. It supports both 32-bit and 16-bit polynomials. The supported 32-bit polynomial is 0x04C11DB7 (IEEE 802.3), while the 16-bit polynomial can be programmed to any value, depending on the needs of the application. Common 16-bit polynomials are 0x1021 (CCITT-16), and 0x8005 (802.15.4, and USB).

### 3.7.2 Crypto Accelerator (CRYPTO)

The Crypto Accelerator is a fast and energy-efficient autonomous hardware encryption and decryption accelerator. EFM32PG1 devices support AES encryption and decryption with 128- or 256-bit keys, ECC over both GF(P) and GF(2<sup>m</sup>), and SHA-1 and SHA-2 (SHA-224 and SHA-256).

Supported modes of operation for AES include: ECB, CTR, CBC, PCBC, CFB, OFB, CBC-MAC, GMAC and CCM.

Supported ECC NIST recommended curves include P-192, P-224, P-256, K-163, K-233, B-163 and B-233.

The CRYPTO module allows fast processing of GCM (AES), ECC and SHA with little CPU intervention. CRYPTO also provides trigger signals for DMA read and write operations.

## 3.8 Analog

### 3.8.1 Analog Port (APORT)

The Analog Port (APORT) is an analog interconnect matrix allowing access to analog modules ADC, ACMP, and IDAC on a flexible selection of pins. Each APORT bus consists of analog switches connected to a common wire. Since many clients can operate differentially, buses are grouped by X/Y pairs.

### 3.8.2 Analog Comparator (ACMP)

The Analog Comparator is used to compare the voltage of two analog inputs, with a digital output indicating which input voltage is higher. Inputs are selected from among internal references and external pins. The tradeoff between response time and current consumption is configurable by software. Two 6-bit reference dividers allow for a wide range of internally-programmable reference sources. The ACMP can also be used to monitor the supply voltage. An interrupt can be generated when the supply falls below or rises above the programmable threshold.

### 3.8.3 Analog to Digital Converter (ADC)

The ADC is a Successive Approximation Register (SAR) architecture, with a resolution of up to 12 bits at up to 1 MSamples/s. The output sample resolution is configurable and additional resolution is possible using integrated hardware for averaging over multiple samples. The ADC includes integrated voltage references and an integrated temperature sensor. Inputs are selectable from a wide range of sources, including pins configurable as either single-ended or differential.

### 3.8.4 Digital to Analog Current Converter (IDAC)

The Digital to Analog Current Converter can source or sink a configurable constant current. This current can be driven on an output pin or routed to the selected ADC input pin for capacitive sensing. The current is programmable between 0.05  $\mu\text{A}$  and 64  $\mu\text{A}$  with several ranges with various step sizes.

## 3.9 Reset Management Unit (RMU)

The RMU is responsible for handling reset of the EFM32PG1. A wide range of reset sources are available, including several power supply monitors, pin reset, software controlled reset, core lockup reset and watchdog reset.

## 3.10 Core and Memory

### 3.10.1 Processor Core

The ARM Cortex-M processor includes a 32-bit RISC processor integrating the following features and tasks in the system:

- ARM Cortex-M4 RISC processor achieving 1.25 Dhrystone MIPS/MHz
- Memory Protection Unit (MPU) supporting up to 8 memory segments
- Up to 256 KB flash program memory
- Up to 32 KB RAM data memory
- Configuration and event handling of all modules
- 2-pin Serial-Wire debug interface

### 3.10.2 Memory System Controller (MSC)

The Memory System Controller (MSC) is the program memory unit of the microcontroller. The flash memory is readable and writable from both the Cortex-M and DMA. The flash memory is divided into two blocks; the main block and the information block. Program code is normally written to the main block, whereas the information block is available for special user data and flash lock bits. There is also a read-only page in the information block containing system and device calibration data. Read and write operations are supported in energy modes EM0 Active and EM1 Sleep.

### 3.10.3 Linked Direct Memory Access Controller (LDMA)

The Linked Direct Memory Access (LDMA) controller features 8 channels capable of performing memory operations independently of software. This reduces both energy consumption and software workload. The LDMA allows operations to be linked together and staged, enabling sophisticated operations to be implemented.



### 3.11 Memory Map

The EFM32PG1 memory map is shown in the figures below. RAM and flash sizes are for the largest memory configuration.

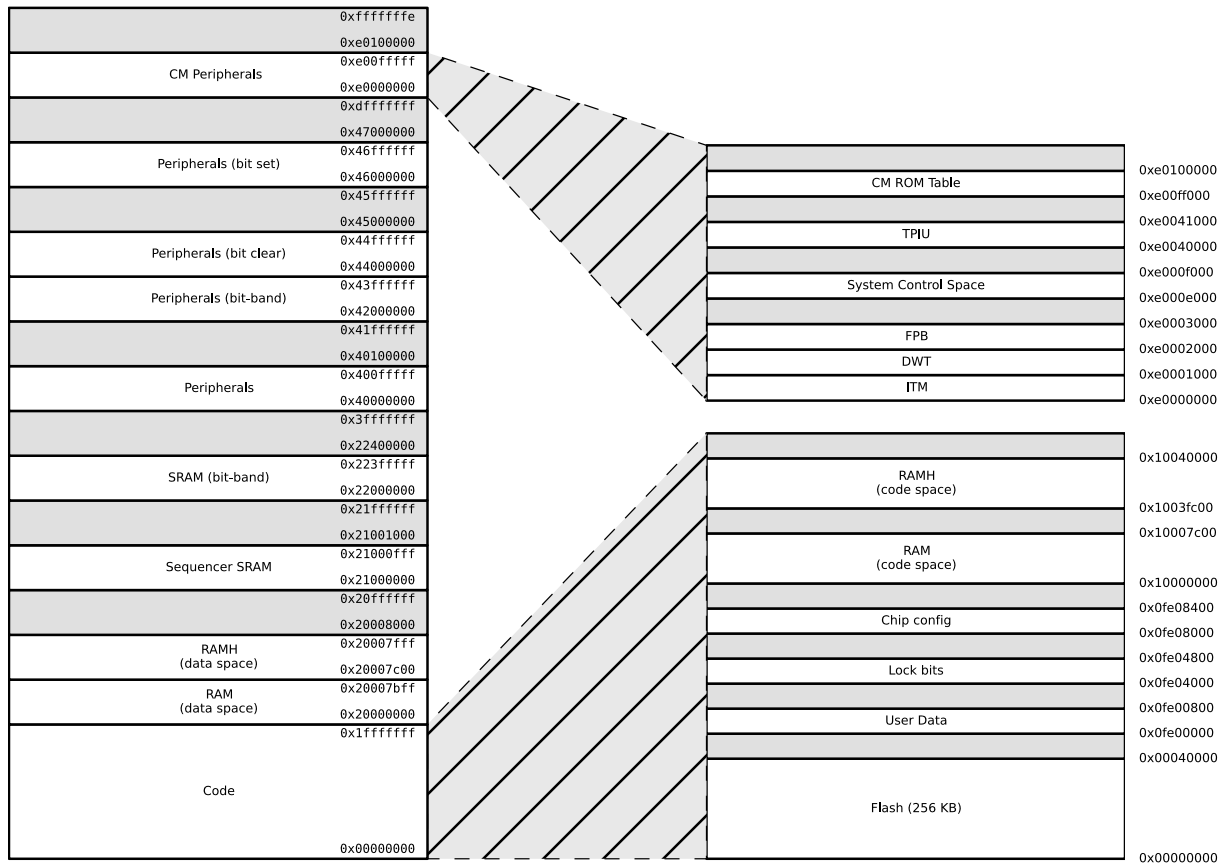

Figure 3.2. EFM32PG1 Memory Map — Core Peripherals and Code Space

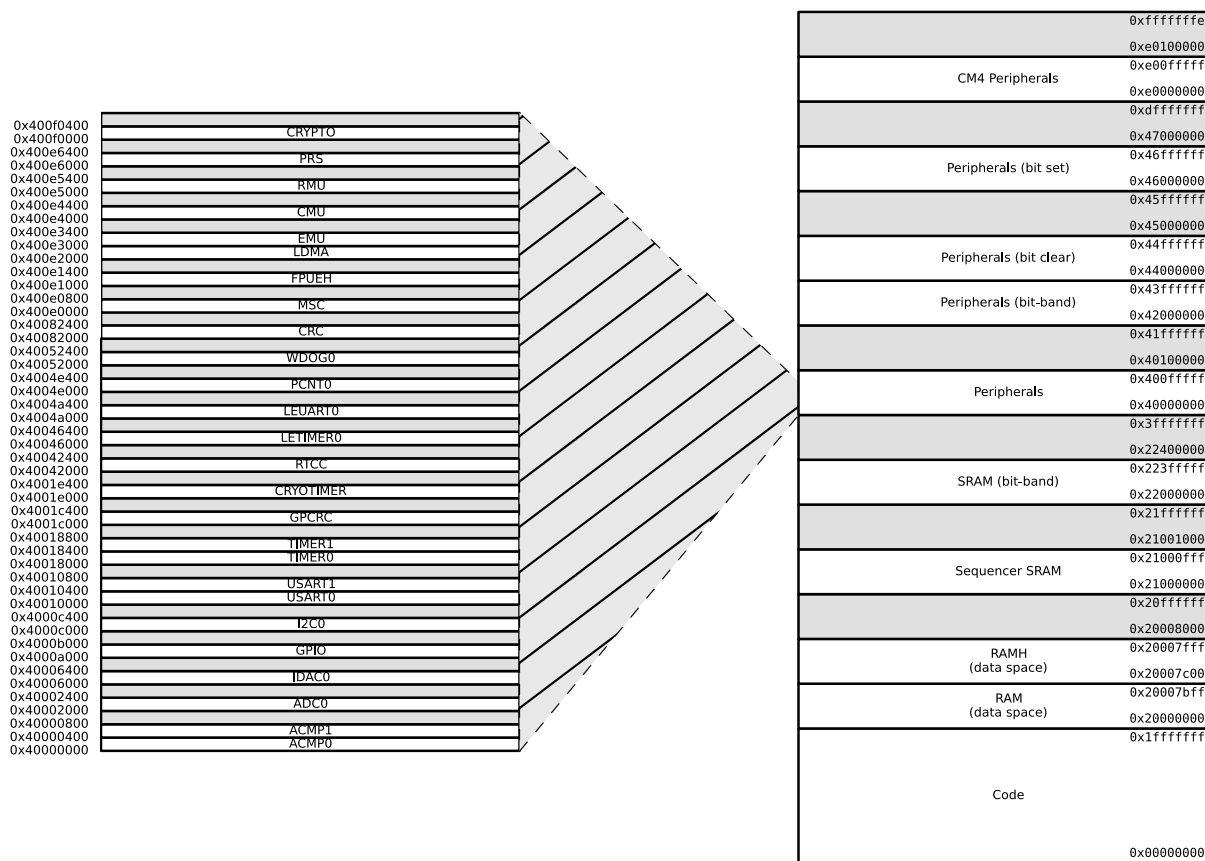

Figure 3.3. EFM32PG1 Memory Map — Peripherals

### 3.12 Configuration Summary

The features of the EFM32PG1 are a subset of the feature set described in the device reference manual. The table below describes device specific implementation of the features. Remaining modules support full configuration.

Table 3.1. Configuration Summary

Module	Configuration	Pin Connections
USART0	IrDA SmartCard	US0_TX, US0_RX, US0_CLK, US0_CS
USART1	IrDA I <sup>2</sup> S SmartCard	US1_TX, US1_RX, US1_CLK, US1_CS
TIMER0	with DTI	TIM0_CC[2:0], TIM0_CDTI[2:0]
TIMER1		TIM1_CC[3:0]

## 4. Electrical Specifications

### 4.1 Electrical Characteristics

All electrical parameters in all tables are specified under the following conditions, unless stated otherwise:

- Typical values are based on  $T_{AMB}=25\text{ }^{\circ}\text{C}$  and  $V_{DD}=3.3\text{ V}$ , by production test and/or technology characterization.
- Minimum and maximum values represent the worst conditions of ambient temperature, supply voltage, and process variation.

Refer to [Table 4.2 General Operating Conditions on page 11](#) for more details about operational supply and temperature limits.

#### 4.1.1 Absolute Maximum Ratings

Stresses above those listed below may cause permanent damage to the device. This is a stress rating only and functional operation of the devices at those or any other conditions above those indicated in the operation listings of this specification is not implied. Exposure to maximum rating conditions for extended periods may affect device reliability. For more information on the available quality and reliability data, see the Quality and Reliability Monitor Report at <http://www.silabs.com/support/quality/pages/default.aspx>.

**Table 4.1. Absolute Maximum Ratings**

Parameter	Symbol	Test Condition	Min	Typ	Max	Unit
Storage temperature range	$T_{STG}$		-50	-	150	$^{\circ}\text{C}$
External main supply voltage	$V_{DDMAX}$		0	-	3.8	V
External main supply voltage ramp rate	$V_{DDRAMPMAX}$		-	-	1	V / $\mu\text{s}$
Voltage on any 5V tolerant GPIO pin <sup>1</sup>	$V_{DIGPIN}$		-0.3	-	Min of 5.25 and IOVDD +2	V
Voltage on non-5V tolerant GPIO pins			-0.3	-	IOVDD+0.3	V
Voltage on HFXO pins	$V_{HFXOPIN}$		-0.3	-	1.4	V
Total current into $V_{SS}$ ground lines (sink)	$I_{VSSMAX}$		-	-	TBD	mA
Current per I/O pin (sink)	$I_{IOMAX}$		-	-	50	mA
Current per I/O pin (source)			-	-	50	mA
Current for all I/O pins (sink)	$I_{IOALLMAX}$		-	-	TBD	mA
Current for all I/O pins (source)			-	-	TBD	mA
Voltage difference between AVDD and VREGVDD	$\Delta V_{DD}$		-	-	0.3	V

**Note:**

1. When a GPIO pin is routed to the analog module through the APORT, the maximum voltage = IOVDD.

## 4.1.2 Operating Conditions

When assigning supply sources, the following requirements must be observed:

- VREGVDD must be the highest voltage in the system
- VREGVDD = AVDD\_n
- DVDD ≤ AVDD\_n
- IOVDD ≤ AVDD\_n

### 4.1.2.1 General Operating Conditions

**Table 4.2. General Operating Conditions**

Parameter	Symbol	Test Condition	Min	Typ	Max	Unit
Ambient temperature range	T <sub>AMB</sub>		-40	25	85	°C
AVDD Supply voltage <sup>1</sup>	V <sub>AVDD</sub>		1.85	3.3	3.8	V
VREGVDD Operating supply voltage <sup>12</sup>	V <sub>VREGVDD</sub>	DCDC in regulation	2.4	3.3	3.8	V
		DCDC in bypass 50mA load	TBD	3.3	3.8	V
		DCDC not in use. DVDD external-ly shorted to VREGVDD	1.85	3.3	3.8	V
DVDD Operating supply voltage	V <sub>DVDD</sub>		1.62	-	V <sub>VREGVDD</sub>	V
IOVDD Operating supply voltage	V <sub>IOVDD</sub>		1.62	-	V <sub>VREGVDD</sub>	V
Difference between AVDD and VREGVDD, ABS(AVDD-VREGVDD)	dV <sub>DD</sub>		-	-	0.1	V
HFCLK frequency	f <sub>CORE</sub>	0 wait-states (MODE = WS0) <sup>3</sup>	-	-	26	MHz
		1 wait-states (MODE = WS1) <sup>3</sup>	-	38.4	40	MHz

**Note:**

1. VREGVDD must be tied to AVDD. Both VREGVDD and AVDD minimum voltages must be satisfied for the part to operate.
2. The minimum voltage required in bypass mode is calculated using R<sub>BYP</sub> from the DCDC specification table. Requirements for other loads can be calculated as  $V_{DVDD\_min} + I_{LOAD} * R_{BYP\_max}$
3. in MSC\_READCTRL register

### 4.1.3 DC-DC Converter

Test conditions:  $L_{DCDC}=4.7\ \mu\text{H}$ ,  $C_{DCDC}=1.0\ \mu\text{F}$ ,  $V_{DCDC\_I}=3.3\ \text{V}$ ,  $V_{DCDC\_O}=1.8\ \text{V}$ ,  $I_{DCDC\_LOAD}=50\ \text{mA}$ , Heavy Drive configuration,  $F_{DCDC\_LN}=8\ \text{MHz}$ , unless otherwise indicated.

**Table 4.3. DC-DC Converter**

Parameter	Symbol	Test Condition	Min	Typ	Max	Unit
Input voltage range	$V_{DCDC\_I}$	Bypass mode	TBD	-	3.8	V
		Low noise (LN) or low power (LP) mode, 1.8 V output, 200 mA load current	2.4	-	3.8	V
Output voltage range	$V_{DCDC\_O}$	1.8V configuration	1.8	-	-	V
Steady-state output ripple	$V_R$	ESR=50 $\Omega$ , ESL=2 nH on 1 $\mu\text{F}$ filter cap.	-	3	-	mVpp
Output voltage under/overshoot	$V_{OV}$	CCM Mode (LNFORCECCM <sup>1</sup> = 1), Load changes between 0 mA and 100 mA	-	100	-	mV
		DCM Mode (LNFORCECCM <sup>1</sup> = 0), Load changes between 0 mA and 10 mA	-	150	-	mV
DC line regulation	$V_{REG}$	Input changes between 3.8 V and 2.4 V	-	0.1	-	%
DC load regulation	$I_{REG}$	Load changes between 0 mA and 100 mA in CCM mode	-	0.1	-	%
Quiescent current	$I_{DCDC\_Q}$	Low power (LP) mode, lowest bias setting (LPCMPBIAS <sup>1</sup> = BIAS0)	-	50	-	nA
		Low noise (LN) mode, DCM configuration (LNFORCECCM <sup>1</sup> = 0)	-	0.3	-	mA
		Low noise (LN) mode, CCM configuration (LNFORCECCM <sup>1</sup> = 1)	-	0.8	-	mA
Regulation DC Accuracy	$ACC_{DC}$	Low noise (LN) mode, 1.8 V target output	TBD	-	-	mV
		Low power (LP) mode, LPCMPBIAS <sup>1</sup> = 0, 1.8 V target output	TBD	-	-	mV
		Low power (LP) mode, LPCMPBIAS <sup>1</sup> = 3, 1.8 V target output	TBD	-	-	mV
Max load current	$I_{LOAD\_MAX}$	Low noise (LN) mode	-	-	200	mA
		Low power (LP) mode, LPCMPBIAS <sup>1</sup> = 3	-	-	10	mA

Parameter	Symbol	Test Condition	Min	Typ	Max	Unit
Capacitance of DCDC output capacitor	C <sub>DCDC</sub>		1	-	10	μF
Inductance of DCDC output inductor	L <sub>DCDC</sub>		-	4.7	-	μH
Resistance in Bypass mode	R <sub>BYP</sub>		TBD	0.8	TBD	Ω
Peak current limit range	I <sub>PK</sub>		20	-	640	mA
Peak current limit step	I <sub>PK_STEP</sub>	Light drive <sup>2</sup>	-	20	-	mA
		Medium Drive <sup>2</sup>	-	40	-	mA
		Heavy Drive <sup>2</sup>	-	80	-	mA

**Note:**

1. In EMU\_DCDCMISCCTRL register
2. Drive levels are defined by configuration of the PSLICESEL and NSLICESEL registers. Light Drive: PSLICESEL=NSLICESEL=3; Medium Drive: PSLICESEL=NSLICESEL=7; Heavy Drive: PSLICESEL=NSLICESEL=15.

#### 4.1.4 Current Consumption

##### 4.1.4.1 Current Consumption 1.85V without DC/DC

Table 4.4. Current Consumption 1.85V without DC/DC

Parameter	Symbol	Test Condition	Min	Typ	Max	Unit
Current consumption in EM0 Active mode, All peripherals disabled	$I_{ACTIVE}$	38.4 MHz crystal, CPU running while loop from flash	-	128	-	$\mu A/MHz$
		38 MHz HFRCO, CPU running Prime from flash	-	87	-	$\mu A/MHz$
		38 MHz HFRCO, CPU running while loop from flash	-	103	-	$\mu A/MHz$
		38 MHz HFRCO, CPU running CoreMark from flash	-	112	-	$\mu A/MHz$
		26 MHz HFRCO, CPU running while loop from flash	-	105	-	$\mu A/MHz$
		1 MHz HFRCO, CPU running while loop from flash	-	235	-	$\mu A/MHz$
Current consumption in EM1 Sleep mode. All peripherals disabled	$I_{EM1}$	38.4 MHz crystal	-	61	-	$\mu A/MHz$
		38 MHz HFRCO	-	35	-	$\mu A/MHz$
		26 MHz HFRCO	-	37	-	$\mu A/MHz$
		1 MHz HFRCO	-	167	-	$\mu A/MHz$
Current consumption in EM2 Deep Sleep mode.	$I_{EM2}$	Full RAM retention and RTCC running from LFXO	-	3.36	-	$\mu A$
		4 kB RAM retention and RTCC running from LFRCO	-	3.13	-	$\mu A$
Current consumption in EM3 Stop mode	$I_{EM3}$	Full RAM retention and CRYO-TIMER running from ULFRCO	-	2.84	-	$\mu A$
Current consumption in EM4H Hibernate mode	$I_{EM4}$	128 byte RAM retention, RTCC running from LFXO	-	1.08	-	$\mu A$
		128 byte RAM retention, CRYO-TIMER running from ULFRCO	-	0.64	-	$\mu A$
		128 byte RAM retention, no RTCC	-	0.63	-	$\mu A$
Current consumption in EM4S Shutoff mode	$I_{EM4S}$	No RAM retention, no RTCC	-	0.02	-	$\mu A$

#### 4.1.4.2 Current Consumption 3.3V without DC/DC

**Table 4.5. Current Consumption 3.3V without DC/DC**

Parameter	Symbol	Test Condition	Min	Typ	Max	Unit
Current consumption in EM0 Active mode, All peripherals disabled	I <sub>ACTIVE</sub>	38.4 MHz crystal, CPU running while loop from flash	-	129	-	μA/MHz
		38 MHz HFRCO, CPU running Prime from flash	-	87	-	μA/MHz
		38 MHz HFRCO, CPU running while loop from flash	-	103	-	μA/MHz
		38 MHz HFRCO, CPU running CoreMark from flash	-	112	-	μA/MHz
		26 MHz HFRCO, CPU running while loop from flash	-	105	-	μA/MHz
		1 MHz HFRCO, CPU running while loop from flash	-	237	-	μA/MHz
Current consumption in EM1 Sleep mode. All peripherals disabled	I <sub>EM1</sub>	38.4 MHz crystal	-	61	-	μA/MHz
		38 MHz HFRCO	-	35	-	μA/MHz
		26 MHz HFRCO	-	37	-	μA/MHz
		1 MHz HFRCO	-	170	-	μA/MHz
Current consumption in EM2 Deep Sleep mode.	I <sub>EM2</sub>	Full RAM retention and RTCC running from LFXO	-	3.47	-	μA
		4 kB RAM retention and RTCC running from LFRCO	-	3.35	-	μA
Current consumption in EM3 Stop mode	I <sub>EM3</sub>	Full RAM retention and CRYO-TIMER running from ULFRCO	-	2.92	-	μA
Current consumption in EM4H Hibernate mode	I <sub>EM4</sub>	128 byte RAM retention, RTCC running from LFXO	-	1.13	-	μA
		128 byte RAM retention, CRYO-TIMER running from ULFRCO	-	0.67	-	μA
		128 byte RAM retention, no RTCC	-	0.66	-	μA
Current consumption in EM4S Shutoff mode	I <sub>EM4S</sub>	no RAM retention, no RTCC	-	0.04	-	μA



4.1.4.3 Current Consumption 3.3V with DC/DC

Table 4.6. Current Consumption 3.3V with DC/DC

Parameter	Symbol	Test Condition	Min	Typ	Max	Unit
Current consumption in EM0 Active mode. All peripherals disabled, DCDC in LowNoise mode	I <sub>ACTIVE</sub>	38.4 MHz crystal, CPU running while loop from flash.	-	87	-	μA/MHz
		38 MHz HFRCO, CPU running Prime from flash	-	63	-	μA/MHz
		38 MHz HFRCO, CPU running while loop from flash	-	72	-	μA/MHz
		38 MHz HFRCO, CPU running CoreMark from flash	-	78	-	μA/MHz
		26 MHz HFRCO, CPU running while loop from flash	-	79	-	μA/MHz
Current consumption in EM1 Sleep mode. All peripherals disabled, DCDC in LowPower mode.	I <sub>EM1</sub>	38.4 MHz crystal	-	39	-	μA/MHz
		38 MHz HFRCO	-	23	-	μA/MHz
		26 MHz HFRCO	-	25	-	μA/MHz
		1 MHz HFRCO	-	142	-	μA/MHz
Current consumption in EM2 Deep Sleep mode.	I <sub>EM2</sub>	Full RAM retention and RTCC running from LFXO	-	1.4	-	μA
		4 kB RAM retention and RTCC running from LFRCO	-	1.4	-	μA
Current consumption in EM3 Stop mode	I <sub>EM3</sub>	Full RAM retention and CRYO-TIMER running from ULFRCO	-	1.1	-	μA
Current consumption in EM4H Hibernate mode	I <sub>EM4</sub>	128 byte RAM retention, RTCC running from LFXO	-	0.9	-	μA
		128 byte RAM retention, CRYO-TIMER running from ULFRCO	-	0.6	-	μA
		128 byte RAM retention, no RTCC	-	0.6	-	μA
Current consumption in EM4S Shutoff mode	I <sub>EM4S</sub>	no RAM retention, no RTCC	-	0.03	-	μA

#### 4.1.5 Wake up times

**Table 4.7. Wake up times**

Parameter	Symbol	Test Condition	Min	Typ	Max	Unit
Wake up from EM2 Deep Sleep	$t_{EM2\_WU}$	Code execution from flash	-	10.7	-	$\mu\text{s}$
		Code execution from RAM	-	3	-	$\mu\text{s}$
Wake up from EM3 Stop	$t_{EM3\_WU}$	Executing from flash	-	10.7	-	$\mu\text{s}$
		Executing from RAM	-	3	-	$\mu\text{s}$
Wake up from EM4H Hiber-nate <sup>1</sup>	$t_{EM4H\_WU}$	Executing from flash	-	60	-	$\mu\text{s}$
Wake up from EM4S Shut-off <sup>1</sup>	$t_{EM4S\_WU}$		-	290	-	$\mu\text{s}$
<b>Note:</b>						
1. Time from wakeup request until first instruction is executed. Wakeup results in device reset.						

#### 4.1.6 Brown Out Detector

**Table 4.8. Brown Out Detector**

Parameter	Symbol	Test Condition	Min	Typ	Max	Unit
DVDD BOD threshold	$V_{DVDDBOD}$	DVDD rising	-	-	TBD	V
		DVDD falling	TBD	-	-	V
DVDD BOD hysteresis	$V_{DVDDBOD\_HYST}$		-	24	-	mV
DVDD response time	$t_{DVDDBOD\_DELAY}$	Supply drops at 0.1V/ $\mu\text{s}$ rate	-	2.4	-	$\mu\text{s}$
AVDD BOD threshold	$V_{AVDDBOD}$	AVDD rising	-	-	1.85	V
		AVDD falling	TBD	-	-	V
AVDD BOD hysteresis	$V_{AVDDBOD\_HYST}$		-	21	-	mV
AVDD response time	$t_{AVDDBOD\_DELAY}$	Supply drops at 0.1V/ $\mu\text{s}$ rate	-	2.4	-	$\mu\text{s}$
EM4 BOD threshold	$V_{EM4BOD}$	AVDD rising	-	-	TBD	V
		AVDD falling	TBD	-	-	V
EM4 BOD hysteresis	$V_{EM4BOD\_HYST}$		-	46	-	mV
EM4 response time	$t_{EM4BOD\_DELAY}$	Supply drops at 0.1V/ $\mu\text{s}$ rate	-	TBD	-	nS

## 4.1.7 Oscillators

### 4.1.7.1 LFXO

Table 4.9. LFXO

Parameter	Symbol	Test Condition	Min	Typ	Max	Unit
Crystal frequency	$f_{LFXO}$		-	32.768	-	kHz
Supported crystal equivalent series resistance (ESR)	$ESR_{LFXO}$		-	-	70	k $\Omega$
Supported range of crystal load capacitance <sup>1</sup>	$C_{LFXO\_CL}$		6	-	18	pF
On-chip tuning cap range <sup>2</sup>	$C_{LFXO\_T}$	On each of LFX TAL_N and LFX TAL_P pins	8	-	40	pF
On-chip tuning cap step size	$SS_{LFXO}$		-	0.25	-	pF
LFXO current consumption on AVDD <sup>3</sup> after startup	$I_{LFXO\_ANA}$	ESR = 30 k $\Omega$ , $C_L$ =12.5 pF, GAIN <sup>4</sup> = 3, AGC <sup>4</sup> = 1	-	273	-	nA
Start- up time	$t_{LFXO}$	ESR=30 k $\Omega$ , $C_L$ =12.5 pF, GAIN <sup>4</sup> =2	-	308	-	ms

**Note:**

1. Total load capacitance as seen by the crystal
2. The effective load capacitance seen by the crystal will be  $C_{LFXO\_T} / 2$ . This is because each XTAL pin has a tuning cap and the two caps will be seen in series by the crystal.
3. Current consumption on DVDD instead if ANASW=1 in EMU\_PWRCTRL register
4. In CMU\_LFXOCTRL register

#### 4.1.7.2 HFXO

Table 4.10. HFXO

Parameter	Symbol	Test Condition	Min	Typ	Max	Unit
Crystal Frequency	$f_{\text{HFXO}}$		38	38.4	40	MHz
Supported crystal equivalent series resistance (ESR)	$\text{ESR}_{\text{HFXO}}$	Crystal frequency 38.4 MHz	-	-	60	$\Omega$
Supported range of crystal load capacitance <sup>1</sup>	$C_{\text{HFXO\_CL}}$		6	-	12	pF
On-chip tuning cap range <sup>2</sup>	$C_{\text{HFXO\_T}}$	On each of HFXTAL_N and HFXTAL_P pins	9	20	25	pF
On-chip tuning capacitance step	$\text{SS}_{\text{HFXO}}$		-	0.04	-	pF
Startup time	$t_{\text{HFXO}}$	38.4 MHz: ESR=50 $\Omega$ , $C_L = 10$ pF, BOOST <sup>3</sup> = 2	-	300	-	$\mu\text{s}$
Frequency Tolerance for the crystal	$\text{FT}_{\text{HFXO}}$	38.4 MHz, ESR = 50 $\Omega$ , CL = 10 pF	-40	-	40	ppm

**Note:**

- Total load capacitance as seen by the crystal
- The effective load capacitance seen by the crystal will be  $C_{\text{HFXO\_T}}/2$ . This is because each XTAL pin has a tuning cap and the two caps will be seen in series by the crystal.
- In CMU\_HFXOCTRL register

#### 4.1.7.3 LFRCO

Table 4.11. LFRCO

Parameter	Symbol	Test Condition	Min	Typ	Max	Unit
Oscillation frequency	$f_{\text{LFRCO}}$		TBD	32.768	TBD	kHz
Startup time	$t_{\text{LFRCO}}$		-	500	-	$\mu\text{s}$
Current consumption on AVDD <sup>1</sup>	$I_{\text{LFRCOANA}}$		-	TBD	-	nA

**Note:**

- Current consumption on DVDD instead if ANASW=1 in EMU\_PWRCTRL register

4.1.7.4 HFRCO and AUXHFRCO

Table 4.12. HFRCO and AUXHFRCO

Parameter	Symbol	Test Condition	Min	Typ	Max	Unit
Oscillation frequency	$f_{\text{HFRCO}}$	38 MHz frequency band	TBD	38	TBD	MHz
		32 MHz frequency band	TBD	32	TBD	MHz
		26 MHz frequency band	TBD	26	TBD	MHz
		19 MHz frequency band	TBD	19	TBD	MHz
		16 MHz frequency band	TBD	16	TBD	MHz
		13 MHz frequency band	TBD	13	TBD	MHz
		7 MHz frequency band	TBD	7	TBD	MHz
		4 MHz frequency band	TBD	4	TBD	MHz
		2 MHz frequency band	TBD	2	TBD	MHz
		1 MHz frequency band	TBD	1	TBD	MHz
Start-up time	$t_{\text{HFRCO}}$	$f_{\text{HFRCO}} \geq 19$ MHz	-	300	-	ns
		$4 < f_{\text{HFRCO}} < 19$ MHz	-	1	-	$\mu\text{s}$
		$f_{\text{HFRCO}} \leq 4$ MHz	-	2.5	-	$\mu\text{s}$
Current consumption on DVDD	$I_{\text{HFRCODIG}}$	$f_{\text{HFRCO}} = 38$ MHz	-	43	-	$\mu\text{A}$
		$f_{\text{HFRCO}} = 32$ MHz	-	37	-	$\mu\text{A}$
		$f_{\text{HFRCO}} = 26$ MHz	-	31	-	$\mu\text{A}$
		$f_{\text{HFRCO}} = 19$ MHz	-	25	TBD	$\mu\text{A}$
		$f_{\text{HFRCO}} = 16$ MHz	-	22	-	$\mu\text{A}$
		$f_{\text{HFRCO}} = 13$ MHz	-	19	-	$\mu\text{A}$
		$f_{\text{HFRCO}} = 7$ MHz	-	12	-	$\mu\text{A}$
		$f_{\text{HFRCO}} = 4$ MHz	-	10	-	$\mu\text{A}$
		$f_{\text{HFRCO}} = 2$ MHz	-	8	-	$\mu\text{A}$
		$f_{\text{HFRCO}} = 1$ MHz	-	7	-	$\mu\text{A}$
Current consumption on AVDD <sup>1</sup>	$I_{\text{HFRCOANA}}$	$f_{\text{HFRCO}} = 38$ MHz	-	161	-	$\mu\text{A}$
		$f_{\text{HFRCO}} = 32$ MHz	-	134	-	$\mu\text{A}$
		$f_{\text{HFRCO}} = 26$ MHz	-	116	-	$\mu\text{A}$
		$f_{\text{HFRCO}} = 19$ MHz	-	101	TBD	$\mu\text{A}$
		$f_{\text{HFRCO}} = 16$ MHz	-	88	-	$\mu\text{A}$
		$f_{\text{HFRCO}} = 13$ MHz	-	81	-	$\mu\text{A}$
		$f_{\text{HFRCO}} = 7$ MHz	-	69	-	$\mu\text{A}$
		$f_{\text{HFRCO}} = 4$ MHz	-	23	-	$\mu\text{A}$
		$f_{\text{HFRCO}} = 2$ MHz	-	23	-	$\mu\text{A}$
		$f_{\text{HFRCO}} = 1$ MHz	-	23	-	$\mu\text{A}$

Parameter	Symbol	Test Condition	Min	Typ	Max	Unit
Step size	SS <sub>HFRCO</sub>	Coarse (% of period)	-	0.8	-	%
		Fine (% of period)	-	0.1	-	%
Period Jitter	PJ <sub>HFRCO</sub>		-	0.2	-	% RMS

**Note:**  
1. Current consumption on DVDD instead if ANASW=1 in EMU\_PWRCTRL register

#### 4.1.7.5 ULFRCO

Table 4.13. ULFRCO

Parameter	Symbol	Test Condition	Min	Typ	Max	Unit
Oscillation frequency	f <sub>ULFRCO</sub>		TBD	1	TBD	kHz

#### 4.1.8 Flash Memory Characteristics

Table 4.14. Flash Memory Characteristics<sup>1</sup>

Parameter	Symbol	Test Condition	Min	Typ	Max	Unit
Flash erase cycles before failure	EC <sub>FLASH</sub>		10000	-	-	cycles
Flash data retention	RET <sub>FLASH</sub>	T <sub>AMB</sub> <85°C	10	-	-	years
Word (32-bit) programming time	t <sub>W_PROG</sub>		20	26	40	µs
Page erase time	t <sub>PERASE</sub>		20	27	40	ms
Mass erase time	t <sub>MERASE</sub>		20	27	40	ms
Device erase time <sup>2</sup>	t <sub>DERASE</sub>		-	60	TBD	ms
Page erase current <sup>3</sup>	I <sub>ERASE</sub>		-	-	3	mA
Mass or Device erase current <sup>3</sup>			-	-	5	mA
Write current <sup>3</sup>	I <sub>WRITE</sub>		-	-	3	mA

**Note:**  
1. Flash data retention information is published in the Quarterly Quality and Reliability Report.  
2. Device erase is issued over the AAP interface and erases all flash, SRAM, the Lock Bit (LB) page, and the User data page Lock Word (ULW)  
3. Measured at 25°C

#### 4.1.9 GPIO

Table 4.15. GPIO

Parameter	Symbol	Test Condition	Min	Typ	Max	Unit
Input low voltage	$V_{IOIL}$		-	-	$IOVDD \cdot 0.3$	V
Input high voltage	$V_{IOIH}$		$IOVDD \cdot 0.7$	-	-	V
Output high voltage relative to IOVDD	$V_{IOOH}$	Sourcing 3 mA, $V_{DD} \geq 3$ V, DRIVESTRENGTH <sup>1</sup> = WEAK	$IOVDD \cdot 0.8$	-	-	V
		Sourcing 1.2 mA, $V_{DD} \geq 1.62$ V, DRIVESTRENGTH <sup>1</sup> = WEAK	$IOVDD \cdot 0.6$	-	-	V
		Sourcing 20 mA, $V_{DD} \geq 3$ V, DRIVESTRENGTH <sup>1</sup> = STRONG	$IOVDD \cdot 0.8$	-	-	V
		Sourcing 8 mA, $V_{DD} \geq 1.62$ V, DRIVESTRENGTH <sup>1</sup> = STRONG	$IOVDD \cdot 0.6$	-	-	V
Output low voltage relative to IOVDD	$V_{IOOL}$	Sinking 3 mA, $V_{DD} \geq 3$ V, DRIVESTRENGTH <sup>1</sup> = WEAK	-	-	$IOVDD \cdot 0.2$	V
		Sinking 1.2 mA, $V_{DD} \geq 1.62$ V, DRIVESTRENGTH <sup>1</sup> = WEAK	-	-	$IOVDD \cdot 0.4$	V
		Sinking 20 mA, $V_{DD} \geq 3$ V, DRIVESTRENGTH <sup>1</sup> = STRONG	-	-	$IOVDD \cdot 0.2$	V
		Sinking 8 mA, $V_{DD} \geq 1.62$ V, DRIVESTRENGTH <sup>1</sup> = STRONG	-	-	$IOVDD \cdot 0.4$	V
Input leakage current	$I_{IOLEAK}$	GPIO $\leq$ IOVDD	-	0.1	TBD	nA
Input leakage current on 5VTOL pads above IOVDD	$I_{5VTOLLEAK}$	$IOVDD < GPIO \leq IOVDD + 2$ V	-	3.3	15	$\mu$ A
I/O pin pull-up resistor	$R_{PU}$		TBD	43	TBD	k $\Omega$
I/O pin pull-down resistor	$R_{PD}$		TBD	43	TBD	k $\Omega$
Pulse width of pulses removed by the glitch suppression filter	$t_{IOGLITCH}$		TBD	25	TBD	ns
Output fall time, From 70% to 30% of $V_{IO}$	$t_{IOOF}$	$C_L = 50$ pF, DRIVESTRENGTH <sup>1</sup> = STRONG, SLEWRATE <sup>1</sup> = 0x6	-	TBD	-	ns
		$C_L = 50$ pF, DRIVESTRENGTH <sup>1</sup> = WEAK, SLEWRATE <sup>1</sup> = 0x6	-	TBD	-	ns

Parameter	Symbol	Test Condition	Min	Typ	Max	Unit
Output rise time, From 30% to 70% of $V_{IO}$	$t_{IOOR}$	$C_L = 50\text{pF}$ , DRIVESTRENGTH <sup>1</sup> = STRONG, SLEWRATE = 0x6 <sup>1</sup>	-	TBD	-	ns
		$C_L = 50\text{pF}$ , DRIVESTRENGTH <sup>1</sup> = WEAK, SLEWRATE <sup>1</sup> = 0x6	-	TBD	-	ns
<b>Note:</b> 1. In GPIO_Pn_CTRL register						

#### 4.1.10 VMON

Table 4.16. VMON

Parameter	Symbol	Test Condition	Min	Typ	Max	Unit
VMON Supply Current	$I_{VMON}$	In EM0 or EM1, 1 supply monitored	-	5.8	-	$\mu\text{A}$
		In EM0 or EM1, 4 supplies monitored	-	11.8	-	$\mu\text{A}$
		In EM2, EM3 or EM4, 1 supply monitored	-	62	-	nA
		In EM2, EM3 or EM4, 4 supplies monitored	-	99	-	nA
VMON Loading of Monitored Supply	$I_{SENSE}$	In EM0 or EM1	-	2	-	$\mu\text{A}$
		In EM2, EM3 or EM4	-	2	-	nA
Threshold range	$V_{VMON\_RANGE}$		TBD	-	TBD	V
Threshold step size	$N_{VMON\_STESP}$	Coarse	-	200	-	mV
		Fine	-	20	-	mV
Response time	$t_{VMON\_RES}$	Supply drops at 1V/ $\mu\text{s}$ rate	-	500	-	ns
Hysteresis	$V_{VMON\_HYST}$		-	26	-	mV



4.1.11 ADC

Table 4.17. ADC

Parameter	Symbol	Test Condition	Min	Typ	Max	Unit
Resolution	$V_{RESOLUTION}$		6	-	12	Bits
Input voltage range	$V_{ADCIN}$	Single ended	0	-	$2 \cdot V_{REF}$	V
		Differential	$-V_{REF}$	-	$V_{REF}$	V
Input range of external reference voltage, single ended and differential	$V_{ADCREFIN\_P}$		1	-	$V_{AVDD}$	V
Power supply rejection <sup>1</sup>	$PSRR_{ADC}$	At DC	-	80	-	dB
Analog input common mode rejection ratio	$CMRR_{ADC}$	At DC	-	80	-	dB
Current on DVDD, using internal reference buffer. Continuous operation. WARMUP-MODE <sup>2</sup> = KEEPADCWARM	$I_{ADCDIG\_CONTINUOUS}$	1 Msps / 16 MHz ADCCLK, BIASPROG <sup>3</sup> = 0	-	145	-	$\mu A$
		250 ksps / 4 MHz ADCCLK, BIASPROG <sup>3</sup> = 6	-	90	-	$\mu A$
		62.5 ksps / 1 MHz ADCCLK, BIASPROG <sup>3</sup> = 15	-	85	-	$\mu A$
Current on AVDD <sup>4</sup> , using internal reference buffer. Continuous operation. WARMUP-MODE <sup>2</sup> = KEEPADCWARM	$I_{ADCANA\_CONTINUOUS}$	1 Msps / 16 MHz ADCCLK, BIASPROG <sup>3</sup> = 0	-	286	-	$\mu A$
		250 ksps / 4 MHz ADCCLK, BIASPROG <sup>3</sup> = 6	-	155	-	$\mu A$
		62.5 ksps / 1 MHz ADCCLK, BIASPROG <sup>3</sup> = 15	-	102	-	$\mu A$
Current on AVDD <sup>4</sup> , using internal reference buffer. Duty-cycled operation. WARMUP-MODE <sup>2</sup> = NORMAL	$I_{ADCANA\_NORMAL}$	35 ksps / 16 MHz ADCCLK, BIASPROG <sup>3</sup> = 0	-	44	-	$\mu A$
		5 ksps / 16 MHz ADCCLK, BIASPROG <sup>3</sup> = 0	-	6	-	$\mu A$
Current on AVDD <sup>4</sup> , using internal reference buffer. Duty-cycled operation. WARMUP-MODE <sup>2</sup> = KEEPINSTANDBY or KEEPINSLOWACC	$I_{ADCANA\_STANDBY}$	125 ksps / 16 MHz ADCCLK, BIASPROG <sup>3</sup> = 0	-	117	-	$\mu A$
		5 ksps / 16 MHz ADCCLK, BIASPROG <sup>3</sup> = 0	-	78	-	$\mu A$
ADC Clock Frequency	$f_{ADCCLK}$		-	-	16	MHz
Throughput rate	$f_{ADCRATE}$		-	-	1	Msps
Conversion time <sup>5</sup>	$t_{ADCCONV}$	6 bit	-	7	-	cycles
		10 bit	-	11	-	cycles
		12 bit	-	13	-	cycles

Parameter	Symbol	Test Condition	Min	Typ	Max	Unit
Startup time of reference generator and ADC core in NORMAL mode	$t_{\text{ADCSTART}}$	WARMUPMODE <sup>2</sup> = NORMAL	-	-	5	$\mu\text{s}$
From standby mode		WARMUPMODE <sup>2</sup> = KEEPIN-STANDBY or KEEPINSLOWACC	-	-	1	$\mu\text{s}$
SNDR at 1Msps and $f_{\text{in}} = 10\text{kHz}$	SNDR <sub>ADC</sub>	Internal reference, 2.5 V full-scale, differential (-1.25, 1.25)	TBD	67	-	dB
		vrefp_in = 1.25 V direct mode with 2.5 V full-scale, differential	-	68	-	dB
Spurious-Free Dynamic Range (SFDR)	SFDR <sub>ADC</sub>	1 MSamples/s, 10 kHz full-scale sine wave	-	75	-	dB
Input referred ADC noise, rms	V <sub>REF_NOISE</sub>	Including quantization noise and distortion	-	380	-	$\mu\text{V}$
Offset Error	V <sub>ADCOFFSETERR</sub>		TBD	1	TBD	LSB
Gain error in ADC	V <sub>ADC_GAIN</sub>	Using internal reference	-	-0.2	TBD	%
		Using external reference	-	-1	-	%
Differential non-linearity (DNL)	DNL <sub>ADC</sub>	12 bit resolution	-1	-	TBD	LSB
Integral non-linearity (INL), End point method	INL <sub>ADC</sub>	12 bit resolution	TBD	-	TBD	LSB
Temperature Sensor Slope	M <sub>TSSENSE</sub>		-	-1.84	-	mV/°C

**Note:**

1. PSRR is referenced to AVDD when ANASW=0 and to DVDD when ANASW=1 in EMU\_PWRCTRL
2. In ADCn\_CNTL register
3. In ADCn\_BIASPROG register
4. Current consumption on DVDD instead if ANASW=1 in EMU\_PWRCTRL register
5. Derived from ADCCLK

## 4.1.12 IDAC

Table 4.18. IDAC

Parameter	Symbol	Test Condition	Min	Typ	Max	Unit
Number of Ranges	$N_{IDAC\_RANGES}$		-	4	-	-
Output Current	$I_{IDAC\_OUT}$	RANGESEL <sup>1</sup> = RANGE0	0.05	-	1.6	μA
		RANGESEL <sup>1</sup> = RANGE1	1.6	-	4.7	μA
		RANGESEL <sup>1</sup> = RANGE2	0.5	-	16	μA
		RANGESEL <sup>1</sup> = RANGE3	2	-	64	μA
Linear steps within each range	$N_{IDAC\_STEPS}$		-	32	-	
Step size	$SS_{IDAC}$	RANGESEL <sup>1</sup> = RANGE0	-	50	-	nA
		RANGESEL <sup>1</sup> = RANGE1	-	100	-	nA
		RANGESEL <sup>1</sup> = RANGE2	-	500	-	nA
		RANGESEL <sup>1</sup> = RANGE3	-	2	-	μA
Total Accuracy, STEPSEL <sup>1</sup> = 0x10	$ACC_{IDAC}$	Continuous mode, AVDD=3.3V, T = 25°C	TBD	-	TBD	%
		Continuous mode	TBD	-	TBD	%
		EM2 or EM3	TBD	-	TBD	%
Start up time	$t_{IDAC\_SU}$	Output within 1% of steady state value	-	5	-	μs
Settling time, (output settled within 1% of steady state value)	$t_{IDAC\_SETTLE}$	Range setting is changed	-	5	-	μs
		Step value is changed	-	1	-	μs
Current consumption in continuous mode <sup>2</sup>	$I_{IDAC}$	Source mode, excluding output current	-	8.9	-	μA
		Sink mode, excluding output current	-	12	-	μA
Output voltage compliance in source mode, source current change relative to current sourced at 0 V	$I_{COMP\_SRC}$	RANGESEL1=0, output voltage = $\min(V_{IOVDD}, V_{AVDD}^2-100\text{ mV})$	-	0.16	-	%
		RANGESEL1=1, output voltage = $\min(V_{IOVDD}, V_{AVDD}^2-100\text{ mV})$	-	0.08	-	%
		RANGESEL1=2, output voltage = $\min(V_{IOVDD}, V_{AVDD}^2-150\text{ mV})$	-	0.03	-	%
		RANGESEL1=3, output voltage = $\min(V_{IOVDD}, V_{AVDD}^2-250\text{ mV})$	-	0.03	-	%

Parameter	Symbol	Test Condition	Min	Typ	Max	Unit
Output voltage compliance in sink mode, sink current change relative to current sunk at IOVDD	I <sub>COMP_SINK</sub>	RANGESEL1=0, output voltage = 100 mV	-	0.82	-	%
		RANGESEL1=1, output voltage = 100 mV	-	0.65	-	%
		RANGESEL1=2, output voltage = 150 mV	-	0.4	-	%
		RANGESEL1=3, output voltage = 250 mV	-	0.25	-	%

**Note:**

1. In IDAC\_CURPROG register
2. The IDAC is supplied by either AVDD, DVDD, or IOVDD based on the setting of ANASW in the EMU\_PWRCTRL register and PWRSEL in the IDAC\_CTRL register. Setting PWRSEL to 1 selects IOVDD. With PWRSEL cleared to 0, ANASW selects between AVDD (0) and DVDD (1).

### 4.1.13 Analog Comparator (ACMP)

Table 4.19. ACMP

Parameter	Symbol	Test Condition	Min	Typ	Max	Unit
Input voltage range	$V_{ACMPIN}$	CMPVDD = ACMPn_CTRL_PWRSEL <sup>1</sup>	0	-	CMPVDD	V
Active current not including voltage reference	$I_{ACMP}$	BIASPROG <sup>2</sup> = 1, FULLBIAS <sup>2</sup> = 0	-	50	-	nA
		BIASPROG <sup>2</sup> = 0x10, FULLBIAS <sup>2</sup> = 0	-	306	-	nA
		BIASPROG <sup>2</sup> = 0x20, FULLBIAS <sup>2</sup> = 1	-	74	TBD	μA
Current consumption of internal voltage reference,	$I_{ACMPREF}$	VLP selected as input using 2.5V Reference / 4 (0.625V)	-	50	-	nA
		VLP selected as input using VDD	-	20	-	nA
		VBDIV selected as input using 1.25 V reference / 1	-	3	-	μA
		VADIV selected as input using VDD/1	-	2	-	μA
Hysteresis	$V_{ACMPHYST}$	HYSTSEL <sup>3</sup> = HYST0	-	0	TBD	mV
		HYSTSEL <sup>3</sup> = HYST1	-	12	-	mV
		HYSTSEL <sup>3</sup> = HYST2	-	22	-	mV
		HYSTSEL <sup>3</sup> = HYST3	-	30	-	mV
		HYSTSEL <sup>3</sup> = HYST4	-	36	-	mV
		HYSTSEL <sup>3</sup> = HYST5	-	41	-	mV
		HYSTSEL <sup>3</sup> = HYST6	-	47	-	mV
		HYSTSEL <sup>3</sup> = HYST7	-	52	-	mV
Comparator delay	$t_{ACMPDELAY}$	BIASPROG <sup>2</sup> = 1, FULLBIAS <sup>2</sup> = 0 <sup>4</sup>	-	30	-	μs
		BIASPROG <sup>2</sup> = 0x10, FULLBIAS <sup>2</sup> = 0 <sup>4</sup>	-	3.7	-	μs
		BIASPROG <sup>2</sup> = 0x20, FULLBIAS <sup>2</sup> = 1 <sup>4</sup>	-	35	-	ns
Startup time of reference generator	$t_{ACMPREF}$	BIASPROG <sup>2</sup> = 0x07, FULLBIAS <sup>2</sup> = 1 <sup>4</sup>	-	TBD	-	μs
Offset voltage	$V_{ACMPOFFSET}$		-	-	TBD	mV
Reference Voltage	$V_{ACMPREF}$	Internal 1.25 V reference	TBD	1.25	TBD	V
		Internal 2.5 V reference	TBD	2.5	TBD	V

Parameter	Symbol	Test Condition	Min	Typ	Max	Unit
Capacitive Sense Internal Resistance	R <sub>CSRES</sub>	CSRESSEL <sup>5</sup> = 0	-	inf	-	kΩ
		CSRESSEL <sup>5</sup> = 1	-	15	-	kΩ
		CSRESSEL <sup>5</sup> = 2	-	27	-	kΩ
		CSRESSEL <sup>5</sup> = 3	-	39	-	kΩ
		CSRESSEL <sup>5</sup> = 4	-	51	-	kΩ
		CSRESSEL <sup>5</sup> = 5	-	102	-	kΩ
		CSRESSEL <sup>5</sup> = 6	-	164	-	kΩ
		CSRESSEL <sup>5</sup> = 7	-	239	-	kΩ

**Note:**

1. CMPVDD is a supply chosen by the setting in ACMPn\_CTRL\_PWRSEL and may be IOVDD, AVDD or DVDD
2. In ACMPn\_CTRL register
3. In ACMPn\_HYSTERESIS register
4. ± 100 mV differential
5. In ACMPn\_INPUTSEL register

The total ACMP current is the sum of the contributions from the ACMP and its internal voltage reference as given as:

$$I_{ACMPTOTAL} = I_{ACMP} + I_{ACMPREF}$$

$I_{ACMPREF}$  is zero if an external voltage reference is used.

#### 4.1.14 I2C

#### I2C Standard-mode (Sm)

**Table 4.20. I2C Standard-mode (Sm)<sup>1</sup>**

Parameter	Symbol	Test Condition	Min	Typ	Max	Unit
SCL clock frequency <sup>2</sup>	f <sub>SCL</sub>		0	-	100	kHz
SCL clock low time	t <sub>LOW</sub>		4.7	-	-	μs
SCL clock high time	t <sub>HIGH</sub>		4	-	-	μs
SDA set-up time	t <sub>SU,DAT</sub>		250	-	-	ns
SDA hold time <sup>3</sup>	t <sub>HD,DAT</sub>		100	-	3450	ns
Repeated START condition set-up time	t <sub>SU,STA</sub>		4.7	-	-	μs
(Repeated) START condition hold time	t <sub>HD,STA</sub>		4	-	-	μs
STOP condition set-up time	t <sub>SU,STO</sub>		4	-	-	μs
Bus free time between a STOP and START condition	t <sub>BUF</sub>		4.7	-	-	μs

**Note:**

1. For CLHR set to 0 in the I2Cn\_CTRL register
2. For the minimum HPPERCLK frequency required in Standard-mode, refer to the I2C chapter in the reference manual
3. The maximum SDA hold time (t<sub>HD,DAT</sub>) needs to be met only when the device does not stretch the low time of SCL (t<sub>LOW</sub>)

## I2C Fast-mode (Fm)

**Table 4.21. I2C Fast-mode (Fm)<sup>1</sup>**

Parameter	Symbol	Test Condition	Min	Typ	Max	Unit
SCL clock frequency <sup>2</sup>	f <sub>SCL</sub>		0	-	400	kHz
SCL clock low time	t <sub>LOW</sub>		1.3	-	-	μs
SCL clock high time	t <sub>HIGH</sub>		0.6	-	-	μs
SDA set-up time	t <sub>SU,DAT</sub>		100	-	-	ns
SDA hold time <sup>3</sup>	t <sub>HD,DAT</sub>		100	-	900	ns
Repeated START condition set-up time	t <sub>SU,STA</sub>		0.6	-	-	μs
(Repeated) START condition hold time	t <sub>HD,STA</sub>		0.6	-	-	μs
STOP condition set-up time	t <sub>SU,STO</sub>		0.6	-	-	μs
Bus free time between a STOP and START condition	t <sub>BUF</sub>		1.3	-	-	μs

**Note:**

1. For CLHR set to 1 in the I2Cn\_CTRL register
2. For the minimum HPPERCLK frequency required in Fast-mode, refer to the I2C chapter in the reference manual
3. The maximum SDA hold time (t<sub>HD,DAT</sub>) needs to be met only when the device does not stretch the low time of SCL (t<sub>LOW</sub>)

## I2C Fast-mode Plus (Fm+)

**Table 4.22. I2C Fast-mode Plus (Fm+)<sup>1</sup>**

Parameter	Symbol	Test Condition	Min	Typ	Max	Unit
SCL clock frequency <sup>2</sup>	f <sub>SCL</sub>		0	-	1000	kHz
SCL clock low time	t <sub>LOW</sub>		0.5	-	-	μs
SCL clock high time	t <sub>HIGH</sub>		0.26	-	-	μs
SDA set-up time	t <sub>SU,DAT</sub>		50	-	-	ns
SDA hold time	t <sub>HD,DAT</sub>		100	-	-	ns
Repeated START condition set-up time	t <sub>SU,STA</sub>		0.26	-	-	μs
(Repeated) START condition hold time	t <sub>HD,STA</sub>		0.26	-	-	μs
STOP condition set-up time	t <sub>SU,STO</sub>		0.26	-	-	μs
Bus free time between a STOP and START condition	t <sub>BUF</sub>		0.5	-	-	μs

**Note:**

1. For CLHR set to 0 or 1 in the I2Cn\_CTRL register
2. For the minimum HPPERCLK frequency required in Fast-mode Plus, refer to the I2C chapter in the reference manual



4.1.15 USART SPI

SPI Master Timing

Table 4.23. SPI Master Timing

Parameter	Symbol	Test Condition	Min	Typ	Max	Unit
SCLK period <sup>1 2</sup>	$t_{SCLK}$		2 * $t_{HFPERCLK}$	-	-	ns
CS to MOSI <sup>1 2</sup>	$t_{CS\_MO}$		0	-	8	ns
SCLK to MOSI <sup>1 2</sup>	$t_{SCLK\_MO}$		3	-	20	ns
MISO setup time <sup>1 2</sup>	$t_{SU\_MI}$	IOVDD = 1.98 V	56	-	-	ns
		IOVDD = 3.0 V	37	-	-	ns
MISO hold time <sup>1 2</sup>	$t_{H\_MI}$		6	-	-	ns

**Note:**

1. Applies for both CLKPHA = 0 and CLKPHA = 1 (figure only shows CLKPHA = 0)
2. Measurement done with 8 pF output loading at 10% and 90% of  $V_{DD}$  (figure shows 50% of  $V_{DD}$ )

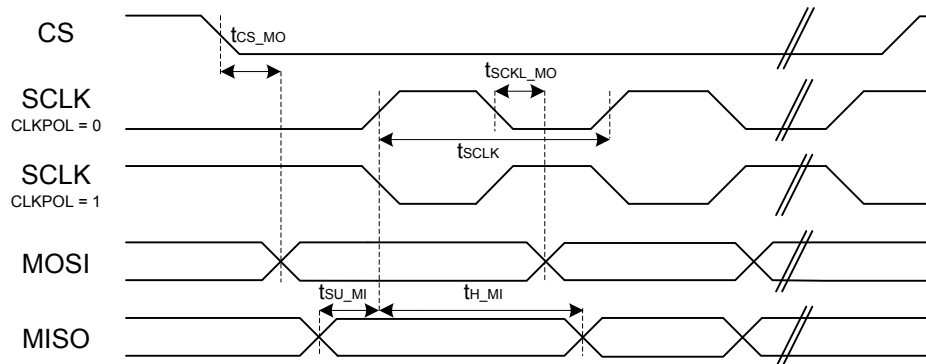

Figure 4.1. SPI Master Timing Diagram

SPI Slave Timing

Table 4.24. SPI Slave Timing

Parameter	Symbol	Test Condition	Min	Typ	Max	Unit
SCKL period <sup>1 2</sup>	$t_{SCLK\_sl}$		2 *	-	-	ns
SCLK high period <sup>1 2</sup>	$t_{SCLK\_hi}$		3 *	-	-	ns
SCLK low period <sup>1 2</sup>	$t_{SCLK\_lo}$		3 *	-	-	ns
CS active to MISO <sup>1 2</sup>	$t_{CS\_ACT\_MI}$		4	-	50	ns
CS disable to MISO <sup>1 2</sup>	$t_{CS\_DIS\_MI}$		4	-	50	ns
MOSI setup time <sup>1 2</sup>	$t_{SU\_MO}$		4	-	-	ns
MOSI hold time <sup>1 2</sup>	$t_{H\_MO}$		3 + 2 *	-	-	ns
SCLK to MISO <sup>1 2</sup>	$t_{SCLK\_MI}$		16 +	-	66 + 2 *	ns

Note:

1. Applies for both CLKPHA = 0 and CLKPHA = 1 (figure only shows CLKPHA = 0)
2. Measurement done with 8 pF output loading at 10% and 90% of  $V_{DD}$  (figure shows 50% of  $V_{DD}$ )

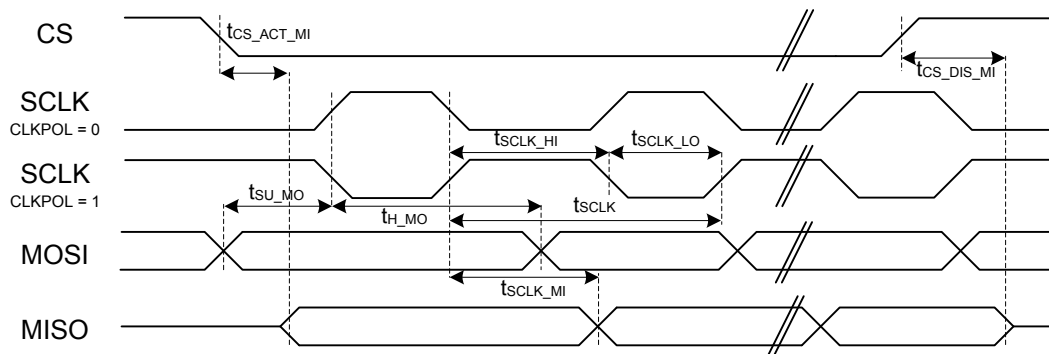

Figure 4.2. SPI Slave Timing Diagram

## 4.2 Typical Performance Curves

Default test conditions: CCM mode, LDCDC = 4.7  $\mu$ H, CDCDC = 1.0  $\mu$ F, VDCDC\_I = 3.3 V, VDCDC\_O = 1.8 V, FDCDC\_LN = 8 MHz

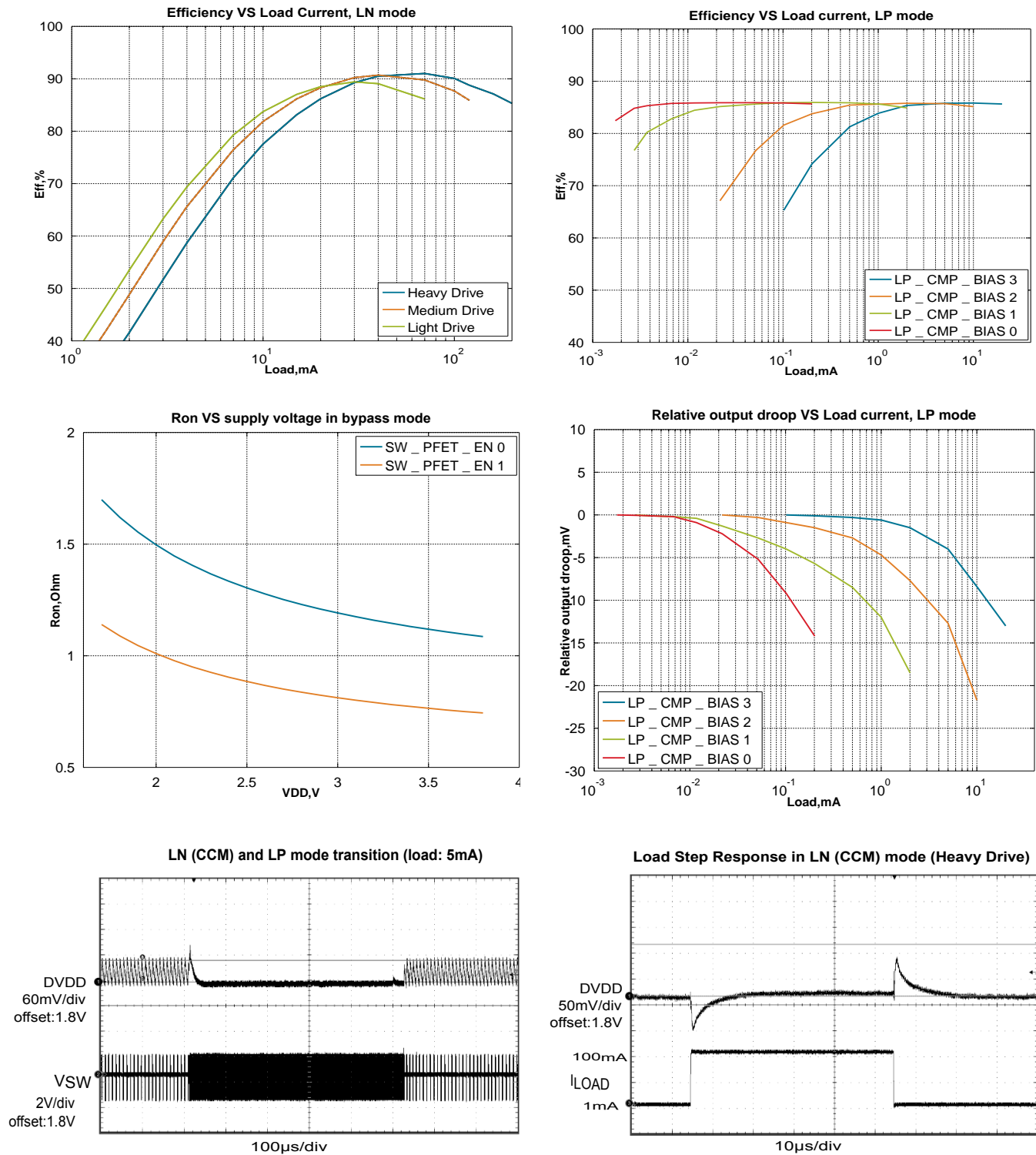

Figure 4.3. DC-DC Converter Typical Performance Characteristics

## 5. Typical Connection Diagrams

### 5.1 Power

Typical power supply connections for direct supply, without using the internal dc-dc converter, are shown in the following figure.

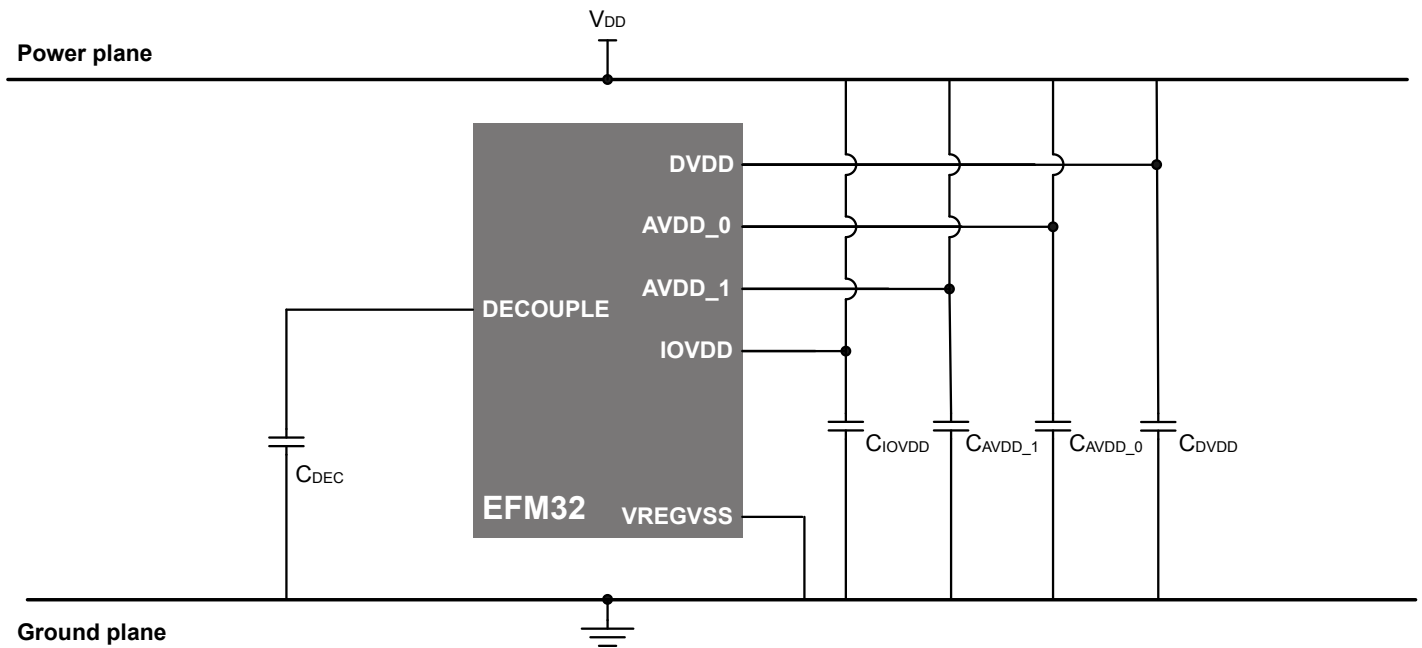

Figure 5.1. EFM32PG1 Typical Application Circuit: Direct Supply Configuration without DC-DC converter

Typical power supply circuits using the internal dc-dc converter are shown below. The MCU operates from the dc-dc converter supply.

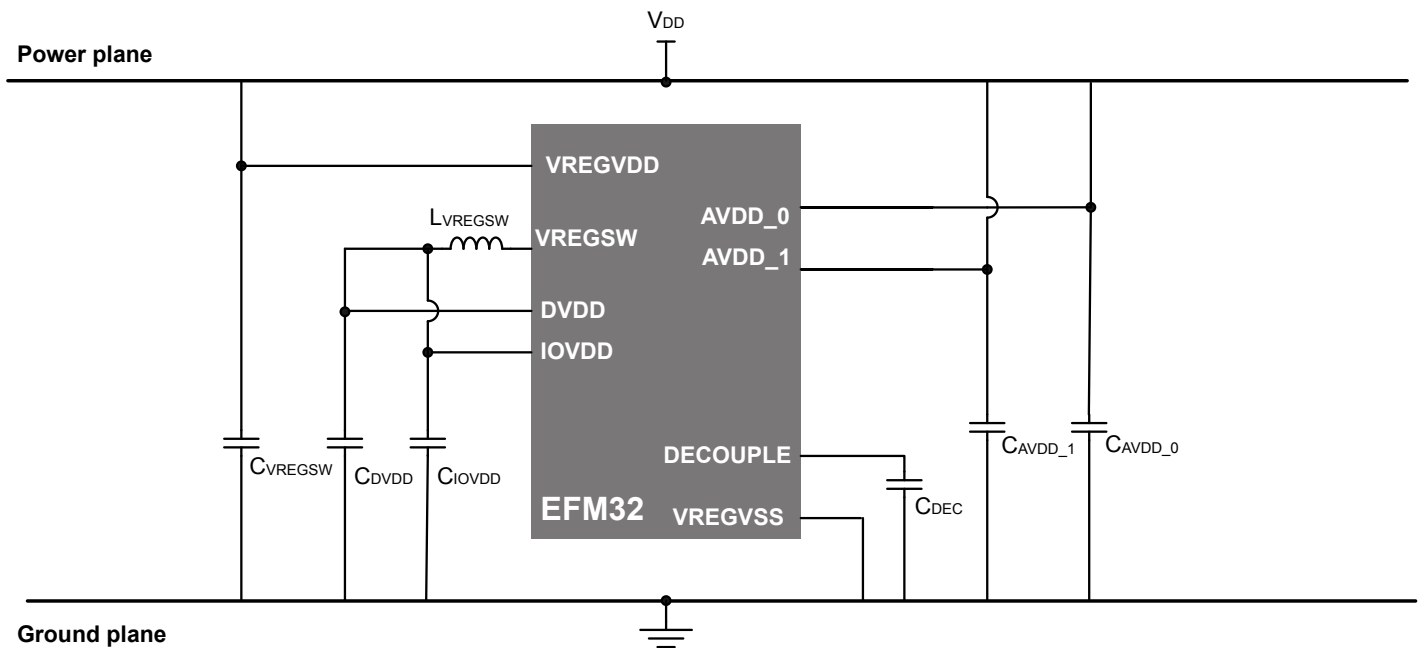

Figure 5.2. EFM32PG1 Typical Application Circuit: Configuration with DC-DC Converter

## 5.2 Other Connections

Other components or connections may be required to meet the system-level requirements. Application Note AN0002: "Hardware Design Considerations" contains detailed information on these connections. Application Notes can be accessed on the Silicon Labs website ([www.silabs.com/32bit-appnotes](http://www.silabs.com/32bit-appnotes)).

## 6. Pin Definitions

### 6.1 EFM32PG1 QFN48 Definition

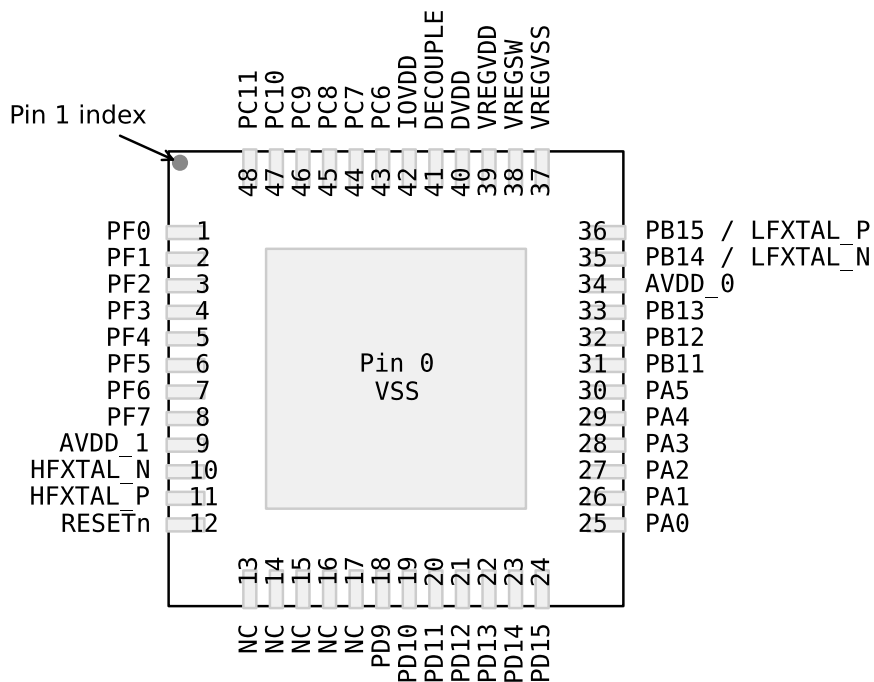

Figure 6.1. EFM32PG1 QFN48 Pinout

Table 6.1. Device Pinout

QFN48 Pin# and Name		Pin Alternate Functionality / Description			
Pin #	Pin Name	Analog	Timers	Communication	Other
0	VSS	Ground			

QFN48 Pin# and Name		Pin Alternate Functionality / Description			
Pin #	Pin Name	Analog	Timers	Communication	Other
1	PF0	BUSAX [ADC0: APORT1XCH16 ACMP0: APORT1XCH16 ACMP1: APORT1XCH16]  BUSBY [ADC0: APORT2YCH16 ACMP0: APORT2YCH16 ACMP1: APORT2YCH16]	TIM0_CC0 #24 TIM0_CC1 #23 TIM0_CC2 #22 TIM0_CDTI0 #21 TIM0_CDTI1 #20 TIM0_CDTI2 #19 TIM1_CC0 #24 TIM1_CC1 #23 TIM1_CC2 #22 TIM1_CC3 #21 LE- TIMO_OUT0 #24 LE- TIMO_OUT1 #23 PCNT0_S0IN #24 PCNT0_S1IN #23	US0_TX #24 US0_RX #23 US0_CLK #22 US0_CS #21 US0_CTS #20 US0_RTS #19 US1_TX #24 US1_RX #23 US1_CLK #22 US1_CS #21 US1_CTS #20 US1_RTS #19 LEU0_TX #24 LEU0_RX #23 I2C0_SDA #24 I2C0_SCL #23	PRS_CH0 #0 PRS_CH1 #7 PRS_CH2 #6 PRS_CH3 #5 ACMP0_O #24 ACMP1_O #24 DBG_SWCLKTCK #0 BOOT_TX
2	PF1	BUSAY [ADC0: APORT1YCH17 ACMP0: APORT1YCH17 ACMP1: APORT1YCH17]  BUSBX [ADC0: APORT2XCH17 ACMP0: APORT2XCH17 ACMP1: APORT2XCH17]	TIM0_CC0 #25 TIM0_CC1 #24 TIM0_CC2 #23 TIM0_CDTI0 #22 TIM0_CDTI1 #21 TIM0_CDTI2 #20 TIM1_CC0 #25 TIM1_CC1 #24 TIM1_CC2 #23 TIM1_CC3 #22 LE- TIMO_OUT0 #25 LE- TIMO_OUT1 #24 PCNT0_S0IN #25 PCNT0_S1IN #24	US0_TX #25 US0_RX #24 US0_CLK #23 US0_CS #22 US0_CTS #21 US0_RTS #20 US1_TX #25 US1_RX #24 US1_CLK #23 US1_CS #22 US1_CTS #21 US1_RTS #20 LEU0_TX #25 LEU0_RX #24 I2C0_SDA #25 I2C0_SCL #24	PRS_CH0 #1 PRS_CH1 #0 PRS_CH2 #7 PRS_CH3 #6 ACMP0_O #25 ACMP1_O #25 DBG_SWDIOTMS #0 BOOT_RX
3	PF2	BUSAX [ADC0: APORT1XCH18 ACMP0: APORT1XCH18 ACMP1: APORT1XCH18]  BUSBY [ADC0: APORT2YCH18 ACMP0: APORT2YCH18 ACMP1: APORT2YCH18]	TIM0_CC0 #26 TIM0_CC1 #25 TIM0_CC2 #24 TIM0_CDTI0 #23 TIM0_CDTI1 #22 TIM0_CDTI2 #21 TIM1_CC0 #26 TIM1_CC1 #25 TIM1_CC2 #24 TIM1_CC3 #23 LE- TIMO_OUT0 #26 LE- TIMO_OUT1 #25 PCNT0_S0IN #26 PCNT0_S1IN #25	US0_TX #26 US0_RX #25 US0_CLK #24 US0_CS #23 US0_CTS #22 US0_RTS #21 US1_TX #26 US1_RX #25 US1_CLK #24 US1_CS #23 US1_CTS #22 US1_RTS #21 LEU0_TX #26 LEU0_RX #25 I2C0_SDA #26 I2C0_SCL #25	CMU_CLK0 #6 PRS_CH0 #2 PRS_CH1 #1 PRS_CH2 #0 PRS_CH3 #7 ACMP0_O #26 ACMP1_O #26 DBG_TDO #0 DBG_SWO #0 GPIO_EM4WU0
4	PF3	BUSAY [ADC0: APORT1YCH19 ACMP0: APORT1YCH19 ACMP1: APORT1YCH19]  BUSBX [ADC0: APORT2XCH19 ACMP0: APORT2XCH19 ACMP1: APORT2XCH19]	TIM0_CC0 #27 TIM0_CC1 #26 TIM0_CC2 #25 TIM0_CDTI0 #24 TIM0_CDTI1 #23 TIM0_CDTI2 #22 TIM1_CC0 #27 TIM1_CC1 #26 TIM1_CC2 #25 TIM1_CC3 #24 LE- TIMO_OUT0 #27 LE- TIMO_OUT1 #26 PCNT0_S0IN #27 PCNT0_S1IN #26	US0_TX #27 US0_RX #26 US0_CLK #25 US0_CS #24 US0_CTS #23 US0_RTS #22 US1_TX #27 US1_RX #26 US1_CLK #25 US1_CS #24 US1_CTS #23 US1_RTS #22 LEU0_TX #27 LEU0_RX #26 I2C0_SDA #27 I2C0_SCL #26	CMU_CLK1 #6 PRS_CH0 #3 PRS_CH1 #2 PRS_CH2 #1 PRS_CH3 #0 ACMP0_O #27 ACMP1_O #27 DBG_TDI #0

QFN48 Pin# and Name		Pin Alternate Functionality / Description			
Pin #	Pin Name	Analog	Timers	Communication	Other
5	PF4	BUSAX [ADC0: APORT1XCH20 ACMP0: APORT1XCH20 ACMP1: APORT1XCH20]  BUSBY [ADC0: APORT2YCH20 ACMP0: APORT2YCH20 ACMP1: APORT2YCH20]	TIM0_CC0 #28 TIM0_CC1 #27 TIM0_CC2 #26 TIM0_CDTI0 #25 TIM0_CDTI1 #24 TIM0_CDTI2 #23 TIM1_CC0 #28 TIM1_CC1 #27 TIM1_CC2 #26 TIM1_CC3 #25 LE- TIMO_OUT0 #28 LE- TIMO_OUT1 #27 PCNT0_S0IN #28 PCNT0_S1IN #27	US0_TX #28 US0_RX #27 US0_CLK #26 US0_CS #25 US0_CTS #24 US0_RTS #23 US1_TX #28 US1_RX #27 US1_CLK #26 US1_CS #25 US1_CTS #24 US1_RTS #23 LEU0_TX #28 LEU0_RX #27 I2C0_SDA #28 I2C0_SCL #27	PRS_CH0 #4 PRS_CH1 #3 PRS_CH2 #2 PRS_CH3 #1 ACMP0_O #28 ACMP1_O #28
6	PF5	BUSAY [ADC0: APORT1YCH21 ACMP0: APORT1YCH21 ACMP1: APORT1YCH21]  BUSBX [ADC0: APORT2XCH21 ACMP0: APORT2XCH21 ACMP1: APORT2XCH21]	TIM0_CC0 #29 TIM0_CC1 #28 TIM0_CC2 #27 TIM0_CDTI0 #26 TIM0_CDTI1 #25 TIM0_CDTI2 #24 TIM1_CC0 #29 TIM1_CC1 #28 TIM1_CC2 #27 TIM1_CC3 #26 LE- TIMO_OUT0 #29 LE- TIMO_OUT1 #28 PCNT0_S0IN #29 PCNT0_S1IN #28	US0_TX #29 US0_RX #28 US0_CLK #27 US0_CS #26 US0_CTS #25 US0_RTS #24 US1_TX #29 US1_RX #28 US1_CLK #27 US1_CS #26 US1_CTS #25 US1_RTS #24 LEU0_TX #29 LEU0_RX #28 I2C0_SDA #29 I2C0_SCL #28	PRS_CH0 #5 PRS_CH1 #4 PRS_CH2 #3 PRS_CH3 #2 ACMP0_O #29 ACMP1_O #29
7	PF6	BUSAX [ADC0: APORT1XCH22 ACMP0: APORT1XCH22 ACMP1: APORT1XCH22]  BUSBY [ADC0: APORT2YCH22 ACMP0: APORT2YCH22 ACMP1: APORT2YCH22]	TIM0_CC0 #30 TIM0_CC1 #29 TIM0_CC2 #28 TIM0_CDTI0 #27 TIM0_CDTI1 #26 TIM0_CDTI2 #25 TIM1_CC0 #30 TIM1_CC1 #29 TIM1_CC2 #28 TIM1_CC3 #27 LE- TIMO_OUT0 #30 LE- TIMO_OUT1 #29 PCNT0_S0IN #30 PCNT0_S1IN #29	US0_TX #30 US0_RX #29 US0_CLK #28 US0_CS #27 US0_CTS #26 US0_RTS #25 US1_TX #30 US1_RX #29 US1_CLK #28 US1_CS #27 US1_CTS #26 US1_RTS #25 LEU0_TX #30 LEU0_RX #29 I2C0_SDA #30 I2C0_SCL #29	CMU_CLK1 #7 PRS_CH0 #6 PRS_CH1 #5 PRS_CH2 #4 PRS_CH3 #3 ACMP0_O #30 ACMP1_O #30
8	PF7	BUSAY [ADC0: APORT1YCH23 ACMP0: APORT1YCH23 ACMP1: APORT1YCH23]  BUSBX [ADC0: APORT2XCH23 ACMP0: APORT2XCH23 ACMP1: APORT2XCH23]	TIM0_CC0 #31 TIM0_CC1 #30 TIM0_CC2 #29 TIM0_CDTI0 #28 TIM0_CDTI1 #27 TIM0_CDTI2 #26 TIM1_CC0 #31 TIM1_CC1 #30 TIM1_CC2 #29 TIM1_CC3 #28 LE- TIMO_OUT0 #31 LE- TIMO_OUT1 #30 PCNT0_S0IN #31 PCNT0_S1IN #30	US0_TX #31 US0_RX #30 US0_CLK #29 US0_CS #28 US0_CTS #27 US0_RTS #26 US1_TX #31 US1_RX #30 US1_CLK #29 US1_CS #28 US1_CTS #27 US1_RTS #26 LEU0_TX #31 LEU0_RX #30 I2C0_SDA #31 I2C0_SCL #30	CMU_CLK0 #7 PRS_CH0 #7 PRS_CH1 #6 PRS_CH2 #5 PRS_CH3 #4 ACMP0_O #31 ACMP1_O #31 GPIO_EM4WU1
9	AVDD_1	Analog power supply 1.			



QFN48 Pin# and Name		Pin Alternate Functionality / Description			
Pin #	Pin Name	Analog	Timers	Communication	Other
10	HFXTAL_N	High Frequency Crystal input pin.			
11	HFXTAL_P	High Frequency Crystal output pin.			
12	RESETn	Reset input, active low. To apply an external reset source to this pin, it is required to only drive this pin low during reset, and let the internal pull-up ensure that reset is released.			
13	NC	No Connect.			
14	NC	No Connect.			
15	NC	No Connect.			
16	NC	No Connect.			
17	NC	No Connect.			
18	PD9	<p>BUSCY [ADC0: APORT3YCH1 ACMP0: APORT3YCH1 ACMP1: APORT3YCH1 IDAC0: APORT1YCH1]</p> <p>BUSDY [ADC0: APORT4XCH1 ACMP0: APORT4XCH1 ACMP1: APORT4XCH1]</p>	<p>TIM0_CC0 #17 TIM0_CC1 #16 TIM0_CC2 #15 TIM0_CDTI0 #14 TIM0_CDTI1 #13 TIM0_CDTI2 #12 TIM1_CC0 #17 TIM1_CC1 #16 TIM1_CC2 #15 TIM1_CC3 #14 LE- TIM0_OUT0 #17 LE- TIM0_OUT1 #16 PCNT0_S0IN #17 PCNT0_S1IN #16</p>	<p>US0_TX #17 US0_RX #16 US0_CLK #15 US0_CS #14 US0_CTS #13 US0_RTS #12 US1_TX #17 US1_RX #16 US1_CLK #15 US1_CS #14 US1_CTS #13 US1_RTS #12 LEU0_TX #17 LEU0_RX #16 I2C0_SDA #17 I2C0_SCL #16</p>	<p>CMU_CLK0 #4 PRS_CH3 #8 PRS_CH4 #0 PRS_CH5 #6 PRS_CH6 #11 ACMP0_O #17 ACMP1_O #17</p>
19	PD10	<p>BUSCX [ADC0: APORT3XCH2 ACMP0: APORT3XCH2 ACMP1: APORT3XCH2 IDAC0: APORT1XCH2]</p> <p>BUSDY [ADC0: APORT4YCH2 ACMP0: APORT4YCH2 ACMP1: APORT4YCH2]</p>	<p>TIM0_CC0 #18 TIM0_CC1 #17 TIM0_CC2 #16 TIM0_CDTI0 #15 TIM0_CDTI1 #14 TIM0_CDTI2 #13 TIM1_CC0 #18 TIM1_CC1 #17 TIM1_CC2 #16 TIM1_CC3 #15 LE- TIM0_OUT0 #18 LE- TIM0_OUT1 #17 PCNT0_S0IN #18 PCNT0_S1IN #17</p>	<p>US0_TX #18 US0_RX #17 US0_CLK #16 US0_CS #15 US0_CTS #14 US0_RTS #13 US1_TX #18 US1_RX #17 US1_CLK #16 US1_CS #15 US1_CTS #14 US1_RTS #13 LEU0_TX #18 LEU0_RX #17 I2C0_SDA #18 I2C0_SCL #17</p>	<p>CMU_CLK1 #4 PRS_CH3 #9 PRS_CH4 #1 PRS_CH5 #0 PRS_CH6 #12 ACMP0_O #18 ACMP1_O #18</p>
20	PD11	<p>BUSCY [ADC0: APORT3YCH3 ACMP0: APORT3YCH3 ACMP1: APORT3YCH3 IDAC0: APORT1YCH3]</p> <p>BUSDY [ADC0: APORT4XCH3 ACMP0: APORT4XCH3 ACMP1: APORT4XCH3]</p>	<p>TIM0_CC0 #19 TIM0_CC1 #18 TIM0_CC2 #17 TIM0_CDTI0 #16 TIM0_CDTI1 #15 TIM0_CDTI2 #14 TIM1_CC0 #19 TIM1_CC1 #18 TIM1_CC2 #17 TIM1_CC3 #16 LE- TIM0_OUT0 #19 LE- TIM0_OUT1 #18 PCNT0_S0IN #19 PCNT0_S1IN #18</p>	<p>US0_TX #19 US0_RX #18 US0_CLK #17 US0_CS #16 US0_CTS #15 US0_RTS #14 US1_TX #19 US1_RX #18 US1_CLK #17 US1_CS #16 US1_CTS #15 US1_RTS #14 LEU0_TX #19 LEU0_RX #18 I2C0_SDA #19 I2C0_SCL #18</p>	<p>PRS_CH3 #10 PRS_CH4 #2 PRS_CH5 #1 PRS_CH6 #13 ACMP0_O #19 ACMP1_O #19</p>

QFN48 Pin# and Name		Pin Alternate Functionality / Description			
Pin #	Pin Name	Analog	Timers	Communication	Other
21	PD12	<p>BUSCX [ADC0: APORT3XCH4 ACMP0: APORT3XCH4 ACMP1: APORT3XCH4 IDAC0: APORT1XCH4]</p> <p>BUSDY [ADC0: APORT4YCH4 ACMP0: APORT4YCH4 ACMP1: APORT4YCH4]</p>	<p>TIM0_CC0 #20 TIM0_CC1 #19 TIM0_CC2 #18 TIM0_CDTI0 #17 TIM0_CDTI1 #16 TIM0_CDTI2 #15 TIM1_CC0 #20 TIM1_CC1 #19 TIM1_CC2 #18 TIM1_CC3 #17 LE- TIM0_OUT0 #20 LE- TIM0_OUT1 #19 PCNT0_S0IN #20 PCNT0_S1IN #19</p>	<p>US0_TX #20 US0_RX #19 US0_CLK #18 US0_CS #17 US0_CTS #16 US0_RTS #15 US1_TX #20 US1_RX #19 US1_CLK #18 US1_CS #17 US1_CTS #16 US1_RTS #15 LEU0_TX #20 LEU0_RX #19 I2C0_SDA #20 I2C0_SCL #19</p>	<p>PRS_CH3 #11 PRS_CH4 #3 PRS_CH5 #2 PRS_CH6 #14 ACMP0_O #20 ACMP1_O #20</p>
22	PD13	<p>BUSCY [ADC0: APORT3YCH5 ACMP0: APORT3YCH5 ACMP1: APORT3YCH5 IDAC0: APORT1YCH5]</p> <p>BUSDX [ADC0: APORT4XCH5 ACMP0: APORT4XCH5 ACMP1: APORT4XCH5]</p>	<p>TIM0_CC0 #21 TIM0_CC1 #20 TIM0_CC2 #19 TIM0_CDTI0 #18 TIM0_CDTI1 #17 TIM0_CDTI2 #16 TIM1_CC0 #21 TIM1_CC1 #20 TIM1_CC2 #19 TIM1_CC3 #18 LE- TIM0_OUT0 #21 LE- TIM0_OUT1 #20 PCNT0_S0IN #21 PCNT0_S1IN #20</p>	<p>US0_TX #21 US0_RX #20 US0_CLK #19 US0_CS #18 US0_CTS #17 US0_RTS #16 US1_TX #21 US1_RX #20 US1_CLK #19 US1_CS #18 US1_CTS #17 US1_RTS #16 LEU0_TX #21 LEU0_RX #20 I2C0_SDA #21 I2C0_SCL #20</p>	<p>PRS_CH3 #12 PRS_CH4 #4 PRS_CH5 #3 PRS_CH6 #15 ACMP0_O #21 ACMP1_O #21</p>
23	PD14	<p>BUSCX [ADC0: APORT3XCH6 ACMP0: APORT3XCH6 ACMP1: APORT3XCH6 IDAC0: APORT1XCH6]</p> <p>BUSDY [ADC0: APORT4YCH6 ACMP0: APORT4YCH6 ACMP1: APORT4YCH6]</p>	<p>TIM0_CC0 #22 TIM0_CC1 #21 TIM0_CC2 #20 TIM0_CDTI0 #19 TIM0_CDTI1 #18 TIM0_CDTI2 #17 TIM1_CC0 #22 TIM1_CC1 #21 TIM1_CC2 #20 TIM1_CC3 #19 LE- TIM0_OUT0 #22 LE- TIM0_OUT1 #21 PCNT0_S0IN #22 PCNT0_S1IN #21</p>	<p>US0_TX #22 US0_RX #21 US0_CLK #20 US0_CS #19 US0_CTS #18 US0_RTS #17 US1_TX #22 US1_RX #21 US1_CLK #20 US1_CS #19 US1_CTS #18 US1_RTS #17 LEU0_TX #22 LEU0_RX #21 I2C0_SDA #22 I2C0_SCL #21</p>	<p>CMU_CLK0 #5 PRS_CH3 #13 PRS_CH4 #5 PRS_CH5 #4 PRS_CH6 #16 ACMP0_O #22 ACMP1_O #22 GPIO_EM4WU4</p>
24	PD15	<p>BUSCY [ADC0: APORT3YCH7 ACMP0: APORT3YCH7 ACMP1: APORT3YCH7 IDAC0: APORT1YCH7]</p> <p>BUSDX [ADC0: APORT4XCH7 ACMP0: APORT4XCH7 ACMP1: APORT4XCH7]</p>	<p>TIM0_CC0 #23 TIM0_CC1 #22 TIM0_CC2 #21 TIM0_CDTI0 #20 TIM0_CDTI1 #19 TIM0_CDTI2 #18 TIM1_CC0 #23 TIM1_CC1 #22 TIM1_CC2 #21 TIM1_CC3 #20 LE- TIM0_OUT0 #23 LE- TIM0_OUT1 #22 PCNT0_S0IN #23 PCNT0_S1IN #22</p>	<p>US0_TX #23 US0_RX #22 US0_CLK #21 US0_CS #20 US0_CTS #19 US0_RTS #18 US1_TX #23 US1_RX #22 US1_CLK #21 US1_CS #20 US1_CTS #19 US1_RTS #18 LEU0_TX #23 LEU0_RX #22 I2C0_SDA #23 I2C0_SCL #22</p>	<p>CMU_CLK1 #5 PRS_CH3 #14 PRS_CH4 #6 PRS_CH5 #5 PRS_CH6 #17 ACMP0_O #23 ACMP1_O #23 DBG_SWO #2</p>

QFN48 Pin# and Name		Pin Alternate Functionality / Description			
Pin #	Pin Name	Analog	Timers	Communication	Other
25	PA0	<p>ADC0_EXTN</p> <p>BUSCX [ADC0: APORT3XCH8 ACMP0: APORT3XCH8 ACMP1: APORT3XCH8 IDAC0: APORT1XCH8]</p> <p>BUSDY [ADC0: APORT4YCH8 ACMP0: APORT4YCH8 ACMP1: APORT4YCH8]</p>	<p>TIM0_CC0 #0</p> <p>TIM0_CC1 #31</p> <p>TIM0_CC2 #30</p> <p>TIM0_CDTI0 #29</p> <p>TIM0_CDTI1 #28</p> <p>TIM0_CDTI2 #27</p> <p>TIM1_CC0 #0</p> <p>TIM1_CC1 #31</p> <p>TIM1_CC2 #30</p> <p>TIM1_CC3 #29 LE-</p> <p>TIM0_OUT0 #0 LE-</p> <p>TIM0_OUT1 #31</p> <p>PCNT0_S0IN #0</p> <p>PCNT0_S1IN #31</p>	<p>US0_TX #0 US0_RX #31</p> <p>US0_CLK #30</p> <p>US0_CS #29 US0_CTS #28</p> <p>US0_RTS #27</p> <p>US1_TX #0 US1_RX #31</p> <p>US1_CLK #30</p> <p>US1_CS #29 US1_CTS #28</p> <p>US1_RTS #27</p> <p>LEU0_TX #0 LEU0_RX #31</p> <p>I2C0_SDA #0</p> <p>I2C0_SCL #31</p>	<p>CMU_CLK1 #0</p> <p>PRS_CH6 #0 PRS_CH7 #10</p> <p>PRS_CH8 #9</p> <p>PRS_CH9 #8 ACMP0_O #0</p> <p>ACMP1_O #0</p>
26	PA1	<p>ADC0_EXTP</p> <p>BUSCY [ADC0: APORT3YCH9 ACMP0: APORT3YCH9 ACMP1: APORT3YCH9 IDAC0: APORT1YCH9]</p> <p>BUSDY [ADC0: APORT4YCH9 ACMP0: APORT4YCH9 ACMP1: APORT4YCH9]</p>	<p>TIM0_CC0 #1</p> <p>TIM0_CC1 #0</p> <p>TIM0_CC2 #31</p> <p>TIM0_CDTI0 #30</p> <p>TIM0_CDTI1 #29</p> <p>TIM0_CDTI2 #28</p> <p>TIM1_CC0 #1</p> <p>TIM1_CC1 #0</p> <p>TIM1_CC2 #31</p> <p>TIM1_CC3 #30 LE-</p> <p>TIM0_OUT0 #1 LE-</p> <p>TIM0_OUT1 #0</p> <p>PCNT0_S0IN #1</p> <p>PCNT0_S1IN #0</p>	<p>US0_TX #1 US0_RX #0</p> <p>US0_CLK #31 US0_CS #30</p> <p>US0_CTS #29</p> <p>US0_RTS #28 US1_TX #1</p> <p>US1_RX #0</p> <p>US1_CLK #31 US1_CS #30</p> <p>US1_CTS #29</p> <p>US1_RTS #28 LEU0_TX #1</p> <p>LEU0_RX #0</p> <p>I2C0_SDA #1 I2C0_SCL #0</p>	<p>CMU_CLK0 #0</p> <p>PRS_CH6 #1 PRS_CH7 #0</p> <p>PRS_CH8 #10</p> <p>PRS_CH9 #9 ACMP0_O #1</p> <p>ACMP1_O #1</p>
27	PA2	<p>BUSCX [ADC0: APORT3XCH10 ACMP0: APORT3XCH10 ACMP1: APORT3XCH10 IDAC0: APORT1XCH10]</p> <p>BUSDY [ADC0: APORT4YCH10 ACMP0: APORT4YCH10 ACMP1: APORT4YCH10]</p>	<p>TIM0_CC0 #2</p> <p>TIM0_CC1 #1</p> <p>TIM0_CC2 #0</p> <p>TIM0_CDTI0 #31</p> <p>TIM0_CDTI1 #30</p> <p>TIM0_CDTI2 #29</p> <p>TIM1_CC0 #2</p> <p>TIM1_CC1 #1</p> <p>TIM1_CC2 #0</p> <p>TIM1_CC3 #31 LE-</p> <p>TIM0_OUT0 #2 LE-</p> <p>TIM0_OUT1 #1</p> <p>PCNT0_S0IN #2</p> <p>PCNT0_S1IN #1</p>	<p>US0_TX #2 US0_RX #1</p> <p>US0_CLK #0 US0_CS #31</p> <p>US0_CTS #30</p> <p>US0_RTS #29 US1_TX #2</p> <p>US1_RX #1</p> <p>US1_CLK #0 US1_CS #31</p> <p>US1_CTS #30</p> <p>US1_RTS #29 LEU0_TX #2</p> <p>LEU0_RX #1</p> <p>I2C0_SDA #2 I2C0_SCL #1</p>	<p>PRS_CH6 #2 PRS_CH7 #1</p> <p>PRS_CH8 #0</p> <p>PRS_CH9 #10</p> <p>ACMP0_O #2</p> <p>ACMP1_O #2</p>
28	PA3	<p>BUSCY [ADC0: APORT3YCH11 ACMP0: APORT3YCH11 ACMP1: APORT3YCH11 IDAC0: APORT1YCH11]</p> <p>BUSDY [ADC0: APORT4YCH11 ACMP0: APORT4YCH11 ACMP1: APORT4YCH11]</p>	<p>TIM0_CC0 #3</p> <p>TIM0_CC1 #2</p> <p>TIM0_CC2 #1</p> <p>TIM0_CDTI0 #0</p> <p>TIM0_CDTI1 #31</p> <p>TIM0_CDTI2 #30</p> <p>TIM1_CC0 #3</p> <p>TIM1_CC1 #2</p> <p>TIM1_CC2 #1</p> <p>TIM1_CC3 #0 LE-</p> <p>TIM0_OUT0 #3 LE-</p> <p>TIM0_OUT1 #2</p> <p>PCNT0_S0IN #3</p> <p>PCNT0_S1IN #2</p>	<p>US0_TX #3 US0_RX #2</p> <p>US0_CLK #1 US0_CS #0</p> <p>US0_CTS #31</p> <p>US0_RTS #30 US1_TX #3</p> <p>US1_RX #2</p> <p>US1_CLK #1 US1_CS #0</p> <p>US1_CTS #31</p> <p>US1_RTS #30 LEU0_TX #3</p> <p>LEU0_RX #2</p> <p>I2C0_SDA #3 I2C0_SCL #2</p>	<p>PRS_CH6 #3 PRS_CH7 #2</p> <p>PRS_CH8 #1</p> <p>PRS_CH9 #0 ACMP0_O #3</p> <p>ACMP1_O #3</p> <p>GPIO_EM4WU8</p>

QFN48 Pin# and Name		Pin Alternate Functionality / Description			
Pin #	Pin Name	Analog	Timers	Communication	Other
29	PA4	<p>BUSCX [ADC0: APORT3XCH12 ACMP0: APORT3XCH12 ACMP1: APORT3XCH12 IDAC0: APORT1XCH12]</p> <p>BUSDY [ADC0: APORT4YCH12 ACMP0: APORT4YCH12 ACMP1: APORT4YCH12]</p>	<p>TIM0_CC0 #4 TIM0_CC1 #3 TIM0_CC2 #2 TIM0_CDTI0 #1 TIM0_CDTI1 #0 TIM0_CDTI2 #31 TIM1_CC0 #4 TIM1_CC1 #3 TIM1_CC2 #2 TIM1_CC3 #1 LE- TIM0_OUT0 #4 LE- TIM0_OUT1 #3 PCNT0_S0IN #4 PCNT0_S1IN #3</p>	<p>US0_TX #4 US0_RX #3 US0_CLK #2 US0_CS #1 US0_CTS #0 US0_RTS #31 US1_TX #4 US1_RX #3 US1_CLK #2 US1_CS #1 US1_CTS #0 US1_RTS #31 LEU0_TX #4 LEU0_RX #3 I2C0_SDA #4 I2C0_SCL #3</p>	<p>PRS_CH6 #4 PRS_CH7 #3 PRS_CH8 #2 PRS_CH9 #1 ACMP0_O #4 ACMP1_O #4</p>
30	PA5	<p>BUSCY [ADC0: APORT3YCH13 ACMP0: APORT3YCH13 ACMP1: APORT3YCH13 IDAC0: APORT1YCH13]</p> <p>BUSDY [ADC0: APORT4YCH13 ACMP0: APORT4YCH13 ACMP1: APORT4YCH13]</p>	<p>TIM0_CC0 #5 TIM0_CC1 #4 TIM0_CC2 #3 TIM0_CDTI0 #2 TIM0_CDTI1 #1 TIM0_CDTI2 #0 TIM1_CC0 #5 TIM1_CC1 #4 TIM1_CC2 #3 TIM1_CC3 #2 LE- TIM0_OUT0 #5 LE- TIM0_OUT1 #4 PCNT0_S0IN #5 PCNT0_S1IN #4</p>	<p>US0_TX #5 US0_RX #4 US0_CLK #3 US0_CS #2 US0_CTS #1 US0_RTS #0 US1_TX #5 US1_RX #4 US1_CLK #3 US1_CS #2 US1_CTS #1 US1_RTS #0 LEU0_TX #5 LEU0_RX #4 I2C0_SDA #5 I2C0_SCL #4</p>	<p>PRS_CH6 #5 PRS_CH7 #4 PRS_CH8 #3 PRS_CH9 #2 ACMP0_O #5 ACMP1_O #5</p>
31	PB11	<p>BUSCY [ADC0: APORT3YCH27 ACMP0: APORT3YCH27 ACMP1: APORT3YCH27 IDAC0: APORT1YCH27]</p> <p>BUSDY [ADC0: APORT4YCH27 ACMP0: APORT4YCH27 ACMP1: APORT4YCH27]</p>	<p>TIM0_CC0 #6 TIM0_CC1 #5 TIM0_CC2 #4 TIM0_CDTI0 #3 TIM0_CDTI1 #2 TIM0_CDTI2 #1 TIM1_CC0 #6 TIM1_CC1 #5 TIM1_CC2 #4 TIM1_CC3 #3 LE- TIM0_OUT0 #6 LE- TIM0_OUT1 #5 PCNT0_S0IN #6 PCNT0_S1IN #5</p>	<p>US0_TX #6 US0_RX #5 US0_CLK #4 US0_CS #3 US0_CTS #2 US0_RTS #1 US1_TX #6 US1_RX #5 US1_CLK #4 US1_CS #3 US1_CTS #2 US1_RTS #1 LEU0_TX #6 LEU0_RX #5 I2C0_SDA #6 I2C0_SCL #5</p>	<p>PRS_CH6 #6 PRS_CH7 #5 PRS_CH8 #4 PRS_CH9 #3 ACMP0_O #6 ACMP1_O #6</p>
32	PB12	<p>BUSCX [ADC0: APORT3XCH28 ACMP0: APORT3XCH28 ACMP1: APORT3XCH28 IDAC0: APORT1XCH28]</p> <p>BUSDY [ADC0: APORT4YCH28 ACMP0: APORT4YCH28 ACMP1: APORT4YCH28]</p>	<p>TIM0_CC0 #7 TIM0_CC1 #6 TIM0_CC2 #5 TIM0_CDTI0 #4 TIM0_CDTI1 #3 TIM0_CDTI2 #2 TIM1_CC0 #7 TIM1_CC1 #6 TIM1_CC2 #5 TIM1_CC3 #4 LE- TIM0_OUT0 #7 LE- TIM0_OUT1 #6 PCNT0_S0IN #7 PCNT0_S1IN #6</p>	<p>US0_TX #7 US0_RX #6 US0_CLK #5 US0_CS #4 US0_CTS #3 US0_RTS #2 US1_TX #7 US1_RX #6 US1_CLK #5 US1_CS #4 US1_CTS #3 US1_RTS #2 LEU0_TX #7 LEU0_RX #6 I2C0_SDA #7 I2C0_SCL #6</p>	<p>PRS_CH6 #7 PRS_CH7 #6 PRS_CH8 #5 PRS_CH9 #4 ACMP0_O #7 ACMP1_O #7</p>

QFN48 Pin# and Name		Pin Alternate Functionality / Description			
Pin #	Pin Name	Analog	Timers	Communication	Other
33	PB13	BUSCY [ADC0: APORT3YCH29 ACMP0: APORT3YCH29 ACMP1: APORT3YCH29 IDAC0: APORT1YCH29]  BUSDX [ADC0: APORT4XCH29 ACMP0: APORT4XCH29 ACMP1: APORT4XCH29]	TIM0_CC0 #8 TIM0_CC1 #7 TIM0_CC2 #6 TIM0_CDTI0 #5 TIM0_CDTI1 #4 TIM0_CDTI2 #3 TIM1_CC0 #8 TIM1_CC1 #7 TIM1_CC2 #6 TIM1_CC3 #5 LE- TIM0_OUT0 #8 LE- TIM0_OUT1 #7 PCNT0_S0IN #8 PCNT0_S1IN #7	US0_TX #8 US0_RX #7 US0_CLK #6 US0_CS #5 US0_CTS #4 US0_RTS #3 US1_TX #8 US1_RX #7 US1_CLK #6 US1_CS #5 US1_CTS #4 US1_RTS #3 LEU0_TX #8 LEU0_RX #7 I2C0_SDA #8 I2C0_SCL #7	PRS_CH6 #8 PRS_CH7 #7 PRS_CH8 #6 PRS_CH9 #5 ACMP0_O #8 ACMP1_O #8 DBG_SWO #1 GPIO_EM4WU9
34	AVDD_0	Analog power supply 0.			
35	PB14	LFXTAL_N  BUSCX [ADC0: APORT3XCH30 ACMP0: APORT3XCH30 ACMP1: APORT3XCH30 IDAC0: APORT1XCH30]  BUSDY [ADC0: APORT4YCH30 ACMP0: APORT4YCH30 ACMP1: APORT4YCH30]	TIM0_CC0 #9 TIM0_CC1 #8 TIM0_CC2 #7 TIM0_CDTI0 #6 TIM0_CDTI1 #5 TIM0_CDTI2 #4 TIM1_CC0 #9 TIM1_CC1 #8 TIM1_CC2 #7 TIM1_CC3 #6 LE- TIM0_OUT0 #9 LE- TIM0_OUT1 #8 PCNT0_S0IN #9 PCNT0_S1IN #8	US0_TX #9 US0_RX #8 US0_CLK #7 US0_CS #6 US0_CTS #5 US0_RTS #4 US1_TX #9 US1_RX #8 US1_CLK #7 US1_CS #6 US1_CTS #5 US1_RTS #4 LEU0_TX #9 LEU0_RX #8 I2C0_SDA #9 I2C0_SCL #8	CMU_CLK1 #1 PRS_CH6 #9 PRS_CH7 #8 PRS_CH8 #7 PRS_CH9 #6 ACMP0_O #9 ACMP1_O #9
36	PB15	LFXTAL_P  BUSCY [ADC0: APORT3YCH31 ACMP0: APORT3YCH31 ACMP1: APORT3YCH31 IDAC0: APORT1YCH31]  BUSDX [ADC0: APORT4XCH31 ACMP0: APORT4XCH31 ACMP1: APORT4XCH31]	TIM0_CC0 #10 TIM0_CC1 #9 TIM0_CC2 #8 TIM0_CDTI0 #7 TIM0_CDTI1 #6 TIM0_CDTI2 #5 TIM1_CC0 #10 TIM1_CC1 #9 TIM1_CC2 #8 TIM1_CC3 #7 LE- TIM0_OUT0 #10 LE- TIM0_OUT1 #9 PCNT0_S0IN #10 PCNT0_S1IN #9	US0_TX #10 US0_RX #9 US0_CLK #8 US0_CS #7 US0_CTS #6 US0_RTS #5 US1_TX #10 US1_RX #9 US1_CLK #8 US1_CS #7 US1_CTS #6 US1_RTS #5 LEU0_TX #10 LEU0_RX #9 I2C0_SDA #10 I2C0_SCL #9	CMU_CLK0 #1 PRS_CH6 #10 PRS_CH7 #9 PRS_CH8 #8 PRS_CH9 #7 ACMP0_O #10 ACMP1_O #10
37	VREGVSS	Voltage regulator VSS			
38	VREGSW	DCDC regulator switching node			
39	VREGVDD	Voltage regulator VDD input			
40	DVDD	Digital power supply.			
41	DECOUPLE	Decouple output for on-chip voltage regulator. An external capacitance of size C <sub>DECOUPLE</sub> is required at this pin.			
42	IOVDD	Digital IO power supply.			

QFN48 Pin# and Name		Pin Alternate Functionality / Description			
Pin #	Pin Name	Analog	Timers	Communication	Other
43	PC6	<p>BUSAX [ADC0: APORT1XCH6 ACMP0: APORT1XCH6 ACMP1: APORT1XCH6]</p> <p>BUSBY [ADC0: APORT2YCH6 ACMP0: APORT2YCH6 ACMP1: APORT2YCH6]</p>	<p>TIM0_CC0 #11 TIM0_CC1 #10 TIM0_CC2 #9 TIM0_CDTI0 #8 TIM0_CDTI1 #7 TIM0_CDTI2 #6 TIM1_CC0 #11 TIM1_CC1 #10 TIM1_CC2 #9 TIM1_CC3 #8 LE- TIM0_OUT0 #11 LE- TIM0_OUT1 #10 PCNT0_S0IN #11 PCNT0_S1IN #10</p>	<p>US0_TX #11 US0_RX #10 US0_CLK #9 US0_CS #8 US0_CTS #7 US0_RTS #6 US1_TX #11 US1_RX #10 US1_CLK #9 US1_CS #8 US1_CTS #7 US1_RTS #6 LEU0_TX #11 LEU0_RX #10 I2C0_SDA #11 I2C0_SCL #10</p>	<p>CMU_CLK0 #2 PRS_CH0 #8 PRS_CH9 #11 PRS_CH10 #0 PRS_CH11 #5 ACMP0_O #11 ACMP1_O #11</p>
44	PC7	<p>BUSAY [ADC0: APORT1YCH7 ACMP0: APORT1YCH7 ACMP1: APORT1YCH7]</p> <p>BUSBX [ADC0: APORT2XCH7 ACMP0: APORT2XCH7 ACMP1: APORT2XCH7]</p>	<p>TIM0_CC0 #12 TIM0_CC1 #11 TIM0_CC2 #10 TIM0_CDTI0 #9 TIM0_CDTI1 #8 TIM0_CDTI2 #7 TIM1_CC0 #12 TIM1_CC1 #11 TIM1_CC2 #10 TIM1_CC3 #9 LE- TIM0_OUT0 #12 LE- TIM0_OUT1 #11 PCNT0_S0IN #12 PCNT0_S1IN #11</p>	<p>US0_TX #12 US0_RX #11 US0_CLK #10 US0_CS #9 US0_CTS #8 US0_RTS #7 US1_TX #12 US1_RX #11 US1_CLK #10 US1_CS #9 US1_CTS #8 US1_RTS #7 LEU0_TX #12 LEU0_RX #11 I2C0_SDA #12 I2C0_SCL #11</p>	<p>CMU_CLK1 #2 PRS_CH0 #9 PRS_CH9 #12 PRS_CH10 #1 PRS_CH11 #0 ACMP0_O #12 ACMP1_O #12</p>
45	PC8	<p>BUSAX [ADC0: APORT1XCH8 ACMP0: APORT1XCH8 ACMP1: APORT1XCH8]</p> <p>BUSBY [ADC0: APORT2YCH8 ACMP0: APORT2YCH8 ACMP1: APORT2YCH8]</p>	<p>TIM0_CC0 #13 TIM0_CC1 #12 TIM0_CC2 #11 TIM0_CDTI0 #10 TIM0_CDTI1 #9 TIM0_CDTI2 #8 TIM1_CC0 #13 TIM1_CC1 #12 TIM1_CC2 #11 TIM1_CC3 #10 LE- TIM0_OUT0 #13 LE- TIM0_OUT1 #12 PCNT0_S0IN #13 PCNT0_S1IN #12</p>	<p>US0_TX #13 US0_RX #12 US0_CLK #11 US0_CS #10 US0_CTS #9 US0_RTS #8 US1_TX #13 US1_RX #12 US1_CLK #11 US1_CS #10 US1_CTS #9 US1_RTS #8 LEU0_TX #13 LEU0_RX #12 I2C0_SDA #13 I2C0_SCL #12</p>	<p>PRS_CH0 #10 PRS_CH9 #13 PRS_CH10 #2 PRS_CH11 #1 ACMP0_O #13 ACMP1_O #13</p>
46	PC9	<p>BUSAY [ADC0: APORT1YCH9 ACMP0: APORT1YCH9 ACMP1: APORT1YCH9]</p> <p>BUSBX [ADC0: APORT2XCH9 ACMP0: APORT2XCH9 ACMP1: APORT2XCH9]</p>	<p>TIM0_CC0 #14 TIM0_CC1 #13 TIM0_CC2 #12 TIM0_CDTI0 #11 TIM0_CDTI1 #10 TIM0_CDTI2 #9 TIM1_CC0 #14 TIM1_CC1 #13 TIM1_CC2 #12 TIM1_CC3 #11 LE- TIM0_OUT0 #14 LE- TIM0_OUT1 #13 PCNT0_S0IN #14 PCNT0_S1IN #13</p>	<p>US0_TX #14 US0_RX #13 US0_CLK #12 US0_CS #11 US0_CTS #10 US0_RTS #9 US1_TX #14 US1_RX #13 US1_CLK #12 US1_CS #11 US1_CTS #10 US1_RTS #9 LEU0_TX #14 LEU0_RX #13 I2C0_SDA #14 I2C0_SCL #13</p>	<p>PRS_CH0 #11 PRS_CH9 #14 PRS_CH10 #3 PRS_CH11 #2 ACMP0_O #14 ACMP1_O #14</p>

QFN48 Pin# and Name		Pin Alternate Functionality / Description			
Pin #	Pin Name	Analog	Timers	Communication	Other
47	PC10	BUSAX [ADC0: APORT1XCH10 ACMP0: APORT1XCH10 ACMP1: APORT1XCH10]  BUSBY [ADC0: APORT2YCH10 ACMP0: APORT2YCH10 ACMP1: APORT2YCH10]	TIM0_CC0 #15 TIM0_CC1 #14 TIM0_CC2 #13 TIM0_CDTI0 #12 TIM0_CDTI1 #11 TIM0_CDTI2 #10 TIM1_CC0 #15 TIM1_CC1 #14 TIM1_CC2 #13 TIM1_CC3 #12 LE- TIM0_OUT0 #15 LE- TIM0_OUT1 #14 PCNT0_S0IN #15 PCNT0_S1IN #14	US0_TX #15 US0_RX #14 US0_CLK #13 US0_CS #12 US0_CTS #11 US0_RTS #10 US1_TX #15 US1_RX #14 US1_CLK #13 US1_CS #12 US1_CTS #11 US1_RTS #10 LEU0_TX #15 LEU0_RX #14 I2C0_SDA #15 I2C0_SCL #14	CMU_CLK1 #3 PRS_CH0 #12 PRS_CH9 #15 PRS_CH10 #4 PRS_CH11 #3 ACMP0_O #15 ACMP1_O #15 GPIO_EM4WU12
48	PC11	BUSAY [ADC0: APORT1YCH11 ACMP0: APORT1YCH11 ACMP1: APORT1YCH11]  BUSBX [ADC0: APORT2XCH11 ACMP0: APORT2XCH11 ACMP1: APORT2XCH11]	TIM0_CC0 #16 TIM0_CC1 #15 TIM0_CC2 #14 TIM0_CDTI0 #13 TIM0_CDTI1 #12 TIM0_CDTI2 #11 TIM1_CC0 #16 TIM1_CC1 #15 TIM1_CC2 #14 TIM1_CC3 #13 LE- TIM0_OUT0 #16 LE- TIM0_OUT1 #15 PCNT0_S0IN #16 PCNT0_S1IN #15	US0_TX #16 US0_RX #15 US0_CLK #14 US0_CS #13 US0_CTS #12 US0_RTS #11 US1_TX #16 US1_RX #15 US1_CLK #14 US1_CS #13 US1_CTS #12 US1_RTS #11 LEU0_TX #16 LEU0_RX #15 I2C0_SDA #16 I2C0_SCL #15	CMU_CLK0 #3 PRS_CH0 #13 PRS_CH9 #16 PRS_CH10 #5 PRS_CH11 #4 ACMP0_O #16 ACMP1_O #16 DBG_SWO #3

### 6.1.1 GPIO Pinout Overview

The GPIO pins are organized as 16-bit ports indicated by letters A through F, and the individual pins on each port is indicated by a number from 15 down to 0.

**Table 6.2. GPIO Pinout**

Port	Pin 15	Pin 14	Pin 13	Pin 12	Pin 11	Pin 10	Pin 9	Pin 8	Pin 7	Pin 6	Pin 5	Pin 4	Pin 3	Pin 2	Pin 1	Pin 0
Port A	-	-	-	-	-	-	-	-	-	-	PA5 (5V)	PA4 (5V)	PA3 (5V)	PA2 (5V)	PA1	PA0
Port B	PB15	PB14	PB13 (5V)	PB12 (5V)	PB11 (5V)	-	-	-	-	-	-	-	-	-	-	-
Port C	-	-	-	-	PC11 (5V)	PC10 (5V)	PC9 (5V)	PC8 (5V)	PC7 (5V)	PC6 (5V)	-	-	-	-	-	-
Port D	PD15 (5V)	PD14 (5V)	PD13 (5V)	PD12 (5V)	PD11 (5V)	PD10 (5V)	PD9 (5V)	-	-	-	-	-	-	-	-	-
Port E	-	-	-	-	-	-	-	-	-	-	-	-	-	-	-	-
Port F	-	-	-	-	-	-	-	-	PF7 (5V)	PF6 (5V)	PF5 (5V)	PF4 (5V)	PF3 (5V)	PF2 (5V)	PF1 (5V)	PF0 (5V)

6.2 EFM32PG1 QFN32 with DC-DC Definition

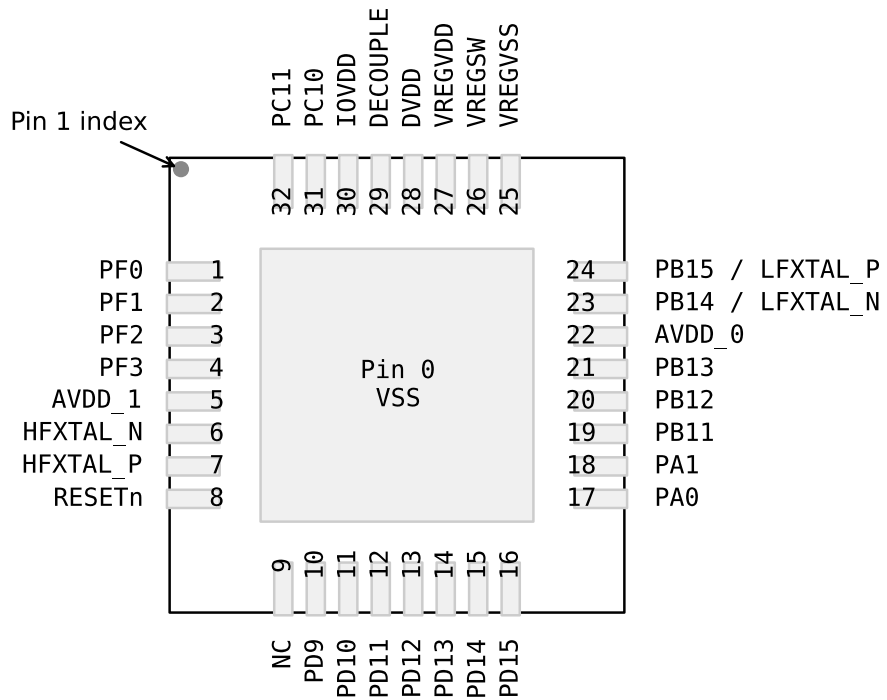

Figure 6.2. EFM32PG1 QFN32 with DC-DC Converter Pinout



Table 6.3. Device Pinout

QFN32 Pin# and Name		Pin Alternate Functionality / Description			
Pin #	Pin Name	Analog	Timers	Communication	Other
0	VSS	Ground			
1	PF0	BUSAX [ADC0: APORT1XCH16 ACMP0: APORT1XCH16 ACMP1: APORT1XCH16]  BUSBY [ADC0: APORT2YCH16 ACMP0: APORT2YCH16 ACMP1: APORT2YCH16]	TIM0_CC0 #24 TIM0_CC1 #23 TIM0_CC2 #22 TIM0_CDTI0 #21 TIM0_CDTI1 #20 TIM0_CDTI2 #19 TIM1_CC0 #24 TIM1_CC1 #23 TIM1_CC2 #22 TIM1_CC3 #21 LE- TIMO_OUT0 #24 LE- TIMO_OUT1 #23 PCNT0_S0IN #24 PCNT0_S1IN #23	US0_TX #24 US0_RX #23 US0_CLK #22 US0_CS #21 US0_CTS #20 US0_RTS #19 US1_TX #24 US1_RX #23 US1_CLK #22 US1_CS #21 US1_CTS #20 US1_RTS #19 LEU0_TX #24 LEU0_RX #23 I2C0_SDA #24 I2C0_SCL #23	PRS_CH0 #0 PRS_CH1 #7 PRS_CH2 #6 PRS_CH3 #5 ACMP0_O #24 ACMP1_O #24 DBG_SWCLKTCK #0 BOOT_TX
2	PF1	BUSAY [ADC0: APORT1YCH17 ACMP0: APORT1YCH17 ACMP1: APORT1YCH17]  BUSBX [ADC0: APORT2XCH17 ACMP0: APORT2XCH17 ACMP1: APORT2XCH17]	TIM0_CC0 #25 TIM0_CC1 #24 TIM0_CC2 #23 TIM0_CDTI0 #22 TIM0_CDTI1 #21 TIM0_CDTI2 #20 TIM1_CC0 #25 TIM1_CC1 #24 TIM1_CC2 #23 TIM1_CC3 #22 LE- TIMO_OUT0 #25 LE- TIMO_OUT1 #24 PCNT0_S0IN #25 PCNT0_S1IN #24	US0_TX #25 US0_RX #24 US0_CLK #23 US0_CS #22 US0_CTS #21 US0_RTS #20 US1_TX #25 US1_RX #24 US1_CLK #23 US1_CS #22 US1_CTS #21 US1_RTS #20 LEU0_TX #25 LEU0_RX #24 I2C0_SDA #25 I2C0_SCL #24	PRS_CH0 #1 PRS_CH1 #0 PRS_CH2 #7 PRS_CH3 #6 ACMP0_O #25 ACMP1_O #25 DBG_SWDIOTMS #0 BOOT_RX
3	PF2	BUSAX [ADC0: APORT1XCH18 ACMP0: APORT1XCH18 ACMP1: APORT1XCH18]  BUSBY [ADC0: APORT2YCH18 ACMP0: APORT2YCH18 ACMP1: APORT2YCH18]	TIM0_CC0 #26 TIM0_CC1 #25 TIM0_CC2 #24 TIM0_CDTI0 #23 TIM0_CDTI1 #22 TIM0_CDTI2 #21 TIM1_CC0 #26 TIM1_CC1 #25 TIM1_CC2 #24 TIM1_CC3 #23 LE- TIMO_OUT0 #26 LE- TIMO_OUT1 #25 PCNT0_S0IN #26 PCNT0_S1IN #25	US0_TX #26 US0_RX #25 US0_CLK #24 US0_CS #23 US0_CTS #22 US0_RTS #21 US1_TX #26 US1_RX #25 US1_CLK #24 US1_CS #23 US1_CTS #22 US1_RTS #21 LEU0_TX #26 LEU0_RX #25 I2C0_SDA #26 I2C0_SCL #25	CMU_CLK0 #6 PRS_CH0 #2 PRS_CH1 #1 PRS_CH2 #0 PRS_CH3 #7 ACMP0_O #26 ACMP1_O #26 DBG_TDO #0 DBG_SWO #0 GPIO_EM4WU0

QFN32 Pin# and Name		Pin Alternate Functionality / Description			
Pin #	Pin Name	Analog	Timers	Communication	Other
4	PF3	BUSAY [ADC0: APORT1YCH19 ACMP0: APORT1YCH19 ACMP1: APORT1YCH19]  BUSBX [ADC0: APORT2XCH19 ACMP0: APORT2XCH19 ACMP1: APORT2XCH19]	TIM0_CC0 #27 TIM0_CC1 #26 TIM0_CC2 #25 TIM0_CDTI0 #24 TIM0_CDTI1 #23 TIM0_CDTI2 #22 TIM1_CC0 #27 TIM1_CC1 #26 TIM1_CC2 #25 TIM1_CC3 #24 LE- TIMO_OUT0 #27 LE- TIMO_OUT1 #26 PCNT0_S0IN #27 PCNT0_S1IN #26	US0_TX #27 US0_RX #26 US0_CLK #25 US0_CS #24 US0_CTS #23 US0_RTS #22 US1_TX #27 US1_RX #26 US1_CLK #25 US1_CS #24 US1_CTS #23 US1_RTS #22 LEU0_TX #27 LEU0_RX #26 I2C0_SDA #27 I2C0_SCL #26	CMU_CLK1 #6 PRS_CH0 #3 PRS_CH1 #2 PRS_CH2 #1 PRS_CH3 #0 ACMP0_O #27 ACMP1_O #27 DBG_TDI #0
5	AVDD_1	Analog power supply 1.			
6	HFXTAL_N	High Frequency Crystal input pin.			
7	HFXTAL_P	High Frequency Crystal output pin.			
8	RESETn	Reset input, active low. To apply an external reset source to this pin, it is required to only drive this pin low during reset, and let the internal pull-up ensure that reset is released.			
9	NC	No Connect.			
10	PD9	BUSCY [ADC0: APORT3YCH1 ACMP0: APORT3YCH1 ACMP1: APORT3YCH1 IDAC0: APORT1YCH1]  BUSDX [ADC0: APORT4XCH1 ACMP0: APORT4XCH1 ACMP1: APORT4XCH1]	TIM0_CC0 #17 TIM0_CC1 #16 TIM0_CC2 #15 TIM0_CDTI0 #14 TIM0_CDTI1 #13 TIM0_CDTI2 #12 TIM1_CC0 #17 TIM1_CC1 #16 TIM1_CC2 #15 TIM1_CC3 #14 LE- TIMO_OUT0 #17 LE- TIMO_OUT1 #16 PCNT0_S0IN #17 PCNT0_S1IN #16	US0_TX #17 US0_RX #16 US0_CLK #15 US0_CS #14 US0_CTS #13 US0_RTS #12 US1_TX #17 US1_RX #16 US1_CLK #15 US1_CS #14 US1_CTS #13 US1_RTS #12 LEU0_TX #17 LEU0_RX #16 I2C0_SDA #17 I2C0_SCL #16	CMU_CLK0 #4 PRS_CH3 #8 PRS_CH4 #0 PRS_CH5 #6 PRS_CH6 #11 ACMP0_O #17 ACMP1_O #17
11	PD10	BUSCX [ADC0: APORT3XCH2 ACMP0: APORT3XCH2 ACMP1: APORT3XCH2 IDAC0: APORT1XCH2]  BUSDY [ADC0: APORT4YCH2 ACMP0: APORT4YCH2 ACMP1: APORT4YCH2]	TIM0_CC0 #18 TIM0_CC1 #17 TIM0_CC2 #16 TIM0_CDTI0 #15 TIM0_CDTI1 #14 TIM0_CDTI2 #13 TIM1_CC0 #18 TIM1_CC1 #17 TIM1_CC2 #16 TIM1_CC3 #15 LE- TIMO_OUT0 #18 LE- TIMO_OUT1 #17 PCNT0_S0IN #18 PCNT0_S1IN #17	US0_TX #18 US0_RX #17 US0_CLK #16 US0_CS #15 US0_CTS #14 US0_RTS #13 US1_TX #18 US1_RX #17 US1_CLK #16 US1_CS #15 US1_CTS #14 US1_RTS #13 LEU0_TX #18 LEU0_RX #17 I2C0_SDA #18 I2C0_SCL #17	CMU_CLK1 #4 PRS_CH3 #9 PRS_CH4 #1 PRS_CH5 #0 PRS_CH6 #12 ACMP0_O #18 ACMP1_O #18

QFN32 Pin# and Name		Pin Alternate Functionality / Description			
Pin #	Pin Name	Analog	Timers	Communication	Other
12	PD11	<p>BUSCY [ADC0: APORT3YCH3 ACMP0: APORT3YCH3 ACMP1: APORT3YCH3 IDAC0: APORT1YCH3]</p> <p>BUSDY [ADC0: APORT4XCH3 ACMP0: APORT4XCH3 ACMP1: APORT4XCH3]</p>	<p>TIM0_CC0 #19 TIM0_CC1 #18 TIM0_CC2 #17 TIM0_CDTI0 #16 TIM0_CDTI1 #15 TIM0_CDTI2 #14 TIM1_CC0 #19 TIM1_CC1 #18 TIM1_CC2 #17 TIM1_CC3 #16 LE- TIM0_OUT0 #19 LE- TIM0_OUT1 #18 PCNT0_S0IN #19 PCNT0_S1IN #18</p>	<p>US0_TX #19 US0_RX #18 US0_CLK #17 US0_CS #16 US0_CTS #15 US0_RTS #14 US1_TX #19 US1_RX #18 US1_CLK #17 US1_CS #16 US1_CTS #15 US1_RTS #14 LEU0_TX #19 LEU0_RX #18 I2C0_SDA #19 I2C0_SCL #18</p>	<p>PRS_CH3 #10 PRS_CH4 #2 PRS_CH5 #1 PRS_CH6 #13 ACMP0_O #19 ACMP1_O #19</p>
13	PD12	<p>BUSCX [ADC0: APORT3XCH4 ACMP0: APORT3XCH4 ACMP1: APORT3XCH4 IDAC0: APORT1XCH4]</p> <p>BUSDY [ADC0: APORT4YCH4 ACMP0: APORT4YCH4 ACMP1: APORT4YCH4]</p>	<p>TIM0_CC0 #20 TIM0_CC1 #19 TIM0_CC2 #18 TIM0_CDTI0 #17 TIM0_CDTI1 #16 TIM0_CDTI2 #15 TIM1_CC0 #20 TIM1_CC1 #19 TIM1_CC2 #18 TIM1_CC3 #17 LE- TIM0_OUT0 #20 LE- TIM0_OUT1 #19 PCNT0_S0IN #20 PCNT0_S1IN #19</p>	<p>US0_TX #20 US0_RX #19 US0_CLK #18 US0_CS #17 US0_CTS #16 US0_RTS #15 US1_TX #20 US1_RX #19 US1_CLK #18 US1_CS #17 US1_CTS #16 US1_RTS #15 LEU0_TX #20 LEU0_RX #19 I2C0_SDA #20 I2C0_SCL #19</p>	<p>PRS_CH3 #11 PRS_CH4 #3 PRS_CH5 #2 PRS_CH6 #14 ACMP0_O #20 ACMP1_O #20</p>
14	PD13	<p>BUSCY [ADC0: APORT3YCH5 ACMP0: APORT3YCH5 ACMP1: APORT3YCH5 IDAC0: APORT1YCH5]</p> <p>BUSDY [ADC0: APORT4XCH5 ACMP0: APORT4XCH5 ACMP1: APORT4XCH5]</p>	<p>TIM0_CC0 #21 TIM0_CC1 #20 TIM0_CC2 #19 TIM0_CDTI0 #18 TIM0_CDTI1 #17 TIM0_CDTI2 #16 TIM1_CC0 #21 TIM1_CC1 #20 TIM1_CC2 #19 TIM1_CC3 #18 LE- TIM0_OUT0 #21 LE- TIM0_OUT1 #20 PCNT0_S0IN #21 PCNT0_S1IN #20</p>	<p>US0_TX #21 US0_RX #20 US0_CLK #19 US0_CS #18 US0_CTS #17 US0_RTS #16 US1_TX #21 US1_RX #20 US1_CLK #19 US1_CS #18 US1_CTS #17 US1_RTS #16 LEU0_TX #21 LEU0_RX #20 I2C0_SDA #21 I2C0_SCL #20</p>	<p>PRS_CH3 #12 PRS_CH4 #4 PRS_CH5 #3 PRS_CH6 #15 ACMP0_O #21 ACMP1_O #21</p>
15	PD14	<p>BUSCX [ADC0: APORT3XCH6 ACMP0: APORT3XCH6 ACMP1: APORT3XCH6 IDAC0: APORT1XCH6]</p> <p>BUSDY [ADC0: APORT4YCH6 ACMP0: APORT4YCH6 ACMP1: APORT4YCH6]</p>	<p>TIM0_CC0 #22 TIM0_CC1 #21 TIM0_CC2 #20 TIM0_CDTI0 #19 TIM0_CDTI1 #18 TIM0_CDTI2 #17 TIM1_CC0 #22 TIM1_CC1 #21 TIM1_CC2 #20 TIM1_CC3 #19 LE- TIM0_OUT0 #22 LE- TIM0_OUT1 #21 PCNT0_S0IN #22 PCNT0_S1IN #21</p>	<p>US0_TX #22 US0_RX #21 US0_CLK #20 US0_CS #19 US0_CTS #18 US0_RTS #17 US1_TX #22 US1_RX #21 US1_CLK #20 US1_CS #19 US1_CTS #18 US1_RTS #17 LEU0_TX #22 LEU0_RX #21 I2C0_SDA #22 I2C0_SCL #21</p>	<p>CMU_CLK0 #5 PRS_CH3 #13 PRS_CH4 #5 PRS_CH5 #4 PRS_CH6 #16 ACMP0_O #22 ACMP1_O #22 GPIO_EM4WU4</p>

QFN32 Pin# and Name		Pin Alternate Functionality / Description			
Pin #	Pin Name	Analog	Timers	Communication	Other
16	PD15	<p>BUSCY [ADC0: APORT3YCH7 ACMP0: APORT3YCH7 ACMP1: APORT3YCH7 IDAC0: APORT1YCH7]</p> <p>BUSDY [ADC0: APORT4XCH7 ACMP0: APORT4XCH7 ACMP1: APORT4XCH7]</p>	<p>TIM0_CC0 #23 TIM0_CC1 #22 TIM0_CC2 #21 TIM0_CDTI0 #20 TIM0_CDTI1 #19 TIM0_CDTI2 #18 TIM1_CC0 #23 TIM1_CC1 #22 TIM1_CC2 #21 TIM1_CC3 #20 LE- TIM0_OUT0 #23 LE- TIM0_OUT1 #22 PCNT0_S0IN #23 PCNT0_S1IN #22</p>	<p>US0_TX #23 US0_RX #22 US0_CLK #21 US0_CS #20 US0_CTS #19 US0_RTS #18 US1_TX #23 US1_RX #22 US1_CLK #21 US1_CS #20 US1_CTS #19 US1_RTS #18 LEU0_TX #23 LEU0_RX #22 I2C0_SDA #23 I2C0_SCL #22</p>	<p>CMU_CLK1 #5 PRS_CH3 #14 PRS_CH4 #6 PRS_CH5 #5 PRS_CH6 #17 ACMP0_O #23 ACMP1_O #23 DBG_SWO #2</p>
17	PA0	<p>ADC0_EXTN</p> <p>BUSCX [ADC0: APORT3XCH8 ACMP0: APORT3XCH8 ACMP1: APORT3XCH8 IDAC0: APORT1XCH8]</p> <p>BUSDY [ADC0: APORT4YCH8 ACMP0: APORT4YCH8 ACMP1: APORT4YCH8]</p>	<p>TIM0_CC0 #0 TIM0_CC1 #31 TIM0_CC2 #30 TIM0_CDTI0 #29 TIM0_CDTI1 #28 TIM0_CDTI2 #27 TIM1_CC0 #0 TIM1_CC1 #31 TIM1_CC2 #30 TIM1_CC3 #29 LE- TIM0_OUT0 #0 LE- TIM0_OUT1 #31 PCNT0_S0IN #0 PCNT0_S1IN #31</p>	<p>US0_TX #0 US0_RX #31 US0_CLK #30 US0_CS #29 US0_CTS #28 US0_RTS #27 US1_TX #0 US1_RX #31 US1_CLK #30 US1_CS #29 US1_CTS #28 US1_RTS #27 LEU0_TX #0 LEU0_RX #31 I2C0_SDA #0 I2C0_SCL #31</p>	<p>CMU_CLK1 #0 PRS_CH6 #0 PRS_CH7 #10 PRS_CH8 #9 PRS_CH9 #8 ACMP0_O #0 ACMP1_O #0</p>
18	PA1	<p>ADC0_EXTP</p> <p>BUSCY [ADC0: APORT3YCH9 ACMP0: APORT3YCH9 ACMP1: APORT3YCH9 IDAC0: APORT1YCH9]</p> <p>BUSDY [ADC0: APORT4XCH9 ACMP0: APORT4XCH9 ACMP1: APORT4XCH9]</p>	<p>TIM0_CC0 #1 TIM0_CC1 #0 TIM0_CC2 #31 TIM0_CDTI0 #30 TIM0_CDTI1 #29 TIM0_CDTI2 #28 TIM1_CC0 #1 TIM1_CC1 #0 TIM1_CC2 #31 TIM1_CC3 #30 LE- TIM0_OUT0 #1 LE- TIM0_OUT1 #0 PCNT0_S0IN #1 PCNT0_S1IN #0</p>	<p>US0_TX #1 US0_RX #0 US0_CLK #31 US0_CS #30 US0_CTS #29 US0_RTS #28 US1_TX #1 US1_RX #0 US1_CLK #31 US1_CS #30 US1_CTS #29 US1_RTS #28 LEU0_TX #1 LEU0_RX #0 I2C0_SDA #1 I2C0_SCL #0</p>	<p>CMU_CLK0 #0 PRS_CH6 #1 PRS_CH7 #0 PRS_CH8 #10 PRS_CH9 #9 ACMP0_O #1 ACMP1_O #1</p>
19	PB11	<p>BUSCY [ADC0: APORT3YCH27 ACMP0: APORT3YCH27 ACMP1: APORT3YCH27 IDAC0: APORT1YCH27]</p> <p>BUSDY [ADC0: APORT4XCH27 ACMP0: APORT4XCH27 ACMP1: APORT4XCH27]</p>	<p>TIM0_CC0 #6 TIM0_CC1 #5 TIM0_CC2 #4 TIM0_CDTI0 #3 TIM0_CDTI1 #2 TIM0_CDTI2 #1 TIM1_CC0 #6 TIM1_CC1 #5 TIM1_CC2 #4 TIM1_CC3 #3 LE- TIM0_OUT0 #6 LE- TIM0_OUT1 #5 PCNT0_S0IN #6 PCNT0_S1IN #5</p>	<p>US0_TX #6 US0_RX #5 US0_CLK #4 US0_CS #3 US0_CTS #2 US0_RTS #1 US1_TX #6 US1_RX #5 US1_CLK #4 US1_CS #3 US1_CTS #2 US1_RTS #1 LEU0_TX #6 LEU0_RX #5 I2C0_SDA #6 I2C0_SCL #5</p>	<p>PRS_CH6 #6 PRS_CH7 #5 PRS_CH8 #4 PRS_CH9 #3 ACMP0_O #6 ACMP1_O #6</p>

QFN32 Pin# and Name		Pin Alternate Functionality / Description			
Pin #	Pin Name	Analog	Timers	Communication	Other
20	PB12	BUSCX [ADC0: APORT3XCH28 ACMP0: APORT3XCH28 ACMP1: APORT3XCH28 IDAC0: APORT1XCH28]  BUSDY [ADC0: APORT4YCH28 ACMP0: APORT4YCH28 ACMP1: APORT4YCH28]	TIM0_CC0 #7 TIM0_CC1 #6 TIM0_CC2 #5 TIM0_CDTI0 #4 TIM0_CDTI1 #3 TIM0_CDTI2 #2 TIM1_CC0 #7 TIM1_CC1 #6 TIM1_CC2 #5 TIM1_CC3 #4 LE- TIM0_OUT0 #7 LE- TIM0_OUT1 #6 PCNT0_S0IN #7 PCNT0_S1IN #6	US0_TX #7 US0_RX #6 US0_CLK #5 US0_CS #4 US0_CTS #3 US0_RTS #2 US1_TX #7 US1_RX #6 US1_CLK #5 US1_CS #4 US1_CTS #3 US1_RTS #2 LEU0_TX #7 LEU0_RX #6 I2C0_SDA #7 I2C0_SCL #6	PRS_CH6 #7 PRS_CH7 #6 PRS_CH8 #5 PRS_CH9 #4 ACMP0_O #7 ACMP1_O #7
21	PB13	BUSCY [ADC0: APORT3YCH29 ACMP0: APORT3YCH29 ACMP1: APORT3YCH29 IDAC0: APORT1YCH29]  BUSDX [ADC0: APORT4XCH29 ACMP0: APORT4XCH29 ACMP1: APORT4XCH29]	TIM0_CC0 #8 TIM0_CC1 #7 TIM0_CC2 #6 TIM0_CDTI0 #5 TIM0_CDTI1 #4 TIM0_CDTI2 #3 TIM1_CC0 #8 TIM1_CC1 #7 TIM1_CC2 #6 TIM1_CC3 #5 LE- TIM0_OUT0 #8 LE- TIM0_OUT1 #7 PCNT0_S0IN #8 PCNT0_S1IN #7	US0_TX #8 US0_RX #7 US0_CLK #6 US0_CS #5 US0_CTS #4 US0_RTS #3 US1_TX #8 US1_RX #7 US1_CLK #6 US1_CS #5 US1_CTS #4 US1_RTS #3 LEU0_TX #8 LEU0_RX #7 I2C0_SDA #8 I2C0_SCL #7	PRS_CH6 #8 PRS_CH7 #7 PRS_CH8 #6 PRS_CH9 #5 ACMP0_O #8 ACMP1_O #8 DBG_SWO #1 GPIO_EM4WU9
22	AVDD_0	Analog power supply 0.			
23	PB14	LFX TAL_N  BUSCX [ADC0: APORT3XCH30 ACMP0: APORT3XCH30 ACMP1: APORT3XCH30 IDAC0: APORT1XCH30]  BUSDY [ADC0: APORT4YCH30 ACMP0: APORT4YCH30 ACMP1: APORT4YCH30]	TIM0_CC0 #9 TIM0_CC1 #8 TIM0_CC2 #7 TIM0_CDTI0 #6 TIM0_CDTI1 #5 TIM0_CDTI2 #4 TIM1_CC0 #9 TIM1_CC1 #8 TIM1_CC2 #7 TIM1_CC3 #6 LE- TIM0_OUT0 #9 LE- TIM0_OUT1 #8 PCNT0_S0IN #9 PCNT0_S1IN #8	US0_TX #9 US0_RX #8 US0_CLK #7 US0_CS #6 US0_CTS #5 US0_RTS #4 US1_TX #9 US1_RX #8 US1_CLK #7 US1_CS #6 US1_CTS #5 US1_RTS #4 LEU0_TX #9 LEU0_RX #8 I2C0_SDA #9 I2C0_SCL #8	CMU_CLK1 #1 PRS_CH6 #9 PRS_CH7 #8 PRS_CH8 #7 PRS_CH9 #6 ACMP0_O #9 ACMP1_O #9

QFN32 Pin# and Name		Pin Alternate Functionality / Description			
Pin #	Pin Name	Analog	Timers	Communication	Other
24	PB15	LFX TAL_P BUSCY [ADC0: APORT3YCH31 ACMP0: APORT3YCH31 ACMP1: APORT3YCH31 IDAC0: APORT1YCH31] BUSDX [ADC0: APORT4XCH31 ACMP0: APORT4XCH31 ACMP1: APORT4XCH31]	TIM0_CC0 #10 TIM0_CC1 #9 TIM0_CC2 #8 TIM0_CDTI0 #7 TIM0_CDTI1 #6 TIM0_CDTI2 #5 TIM1_CC0 #10 TIM1_CC1 #9 TIM1_CC2 #8 TIM1_CC3 #7 LE- TIM0_OUT0 #10 LE- TIM0_OUT1 #9 PCNT0_S0IN #10 PCNT0_S1IN #9	US0_TX #10 US0_RX #9 US0_CLK #8 US0_CS #7 US0_CTS #6 US0_RTS #5 US1_TX #10 US1_RX #9 US1_CLK #8 US1_CS #7 US1_CTS #6 US1_RTS #5 LEU0_TX #10 LEU0_RX #9 I2C0_SDA #10 I2C0_SCL #9	CMU_CLK0 #1 PRS_CH6 #10 PRS_CH7 #9 PRS_CH8 #8 PRS_CH9 #7 ACMP0_O #10 ACMP1_O #10
25	VREGVSS	Voltage regulator VSS			
26	VREGSW	DCDC regulator switching node			
27	VREGVDD	Voltage regulator VDD input			
28	DVDD	Digital power supply.			
29	DECOUPLE	Decouple output for on-chip voltage regulator. An external capacitance of size C <sub>DECOUPLE</sub> is required at this pin.			
30	IOVDD	Digital IO power supply.			
31	PC10	BUSAX [ADC0: APORT1XCH10 ACMP0: APORT1XCH10 ACMP1: APORT1XCH10] BUSBY [ADC0: APORT2YCH10 ACMP0: APORT2YCH10 ACMP1: APORT2YCH10]	TIM0_CC0 #15 TIM0_CC1 #14 TIM0_CC2 #13 TIM0_CDTI0 #12 TIM0_CDTI1 #11 TIM0_CDTI2 #10 TIM1_CC0 #15 TIM1_CC1 #14 TIM1_CC2 #13 TIM1_CC3 #12 LE- TIM0_OUT0 #15 LE- TIM0_OUT1 #14 PCNT0_S0IN #15 PCNT0_S1IN #14	US0_TX #15 US0_RX #14 US0_CLK #13 US0_CS #12 US0_CTS #11 US0_RTS #10 US1_TX #15 US1_RX #14 US1_CLK #13 US1_CS #12 US1_CTS #11 US1_RTS #10 LEU0_TX #15 LEU0_RX #14 I2C0_SDA #15 I2C0_SCL #14	CMU_CLK1 #3 PRS_CH0 #12 PRS_CH9 #15 PRS_CH10 #4 PRS_CH11 #3 ACMP0_O #15 ACMP1_O #15 GPIO_EM4WU12
32	PC11	BUSAY [ADC0: APORT1YCH11 ACMP0: APORT1YCH11 ACMP1: APORT1YCH11] BUSBX [ADC0: APORT2XCH11 ACMP0: APORT2XCH11 ACMP1: APORT2XCH11]	TIM0_CC0 #16 TIM0_CC1 #15 TIM0_CC2 #14 TIM0_CDTI0 #13 TIM0_CDTI1 #12 TIM0_CDTI2 #11 TIM1_CC0 #16 TIM1_CC1 #15 TIM1_CC2 #14 TIM1_CC3 #13 LE- TIM0_OUT0 #16 LE- TIM0_OUT1 #15 PCNT0_S0IN #16 PCNT0_S1IN #15	US0_TX #16 US0_RX #15 US0_CLK #14 US0_CS #13 US0_CTS #12 US0_RTS #11 US1_TX #16 US1_RX #15 US1_CLK #14 US1_CS #13 US1_CTS #12 US1_RTS #11 LEU0_TX #16 LEU0_RX #15 I2C0_SDA #16 I2C0_SCL #15	CMU_CLK0 #3 PRS_CH0 #13 PRS_CH9 #16 PRS_CH10 #5 PRS_CH11 #4 ACMP0_O #16 ACMP1_O #16 DBG_SWO #3

### 6.2.1 GPIO Pinout Overview

The GPIO pins are organized as 16-bit ports indicated by letters A through F, and the individual pins on each port is indicated by a number from 15 down to 0.

**Table 6.4. GPIO Pinout**

Port	Pin 15	Pin 14	Pin 13	Pin 12	Pin 11	Pin 10	Pin 9	Pin 8	Pin 7	Pin 6	Pin 5	Pin 4	Pin 3	Pin 2	Pin 1	Pin 0
Port A	-	-	-	-	-	-	-	-	-	-	-	-	-	-	PA1	PA0
Port B	PB15	PB14	PB13 (5V)	PB12 (5V)	PB11 (5V)	-	-	-	-	-	-	-	-	-	-	-
Port C	-	-	-	-	PC11 (5V)	PC10 (5V)	-	-	-	-	-	-	-	-	-	-
Port D	PD15 (5V)	PD14 (5V)	PD13 (5V)	PD12 (5V)	PD11 (5V)	PD10 (5V)	PD9 (5V)	-	-	-	-	-	-	-	-	-
Port E	-	-	-	-	-	-	-	-	-	-	-	-	-	-	-	-
Port F	-	-	-	-	-	-	-	-	-	-	-	-	PF3 (5V)	PF2 (5V)	PF1 (5V)	PF0 (5V)

6.3 EFM32PG1 QFN32 without DC-DC Definition

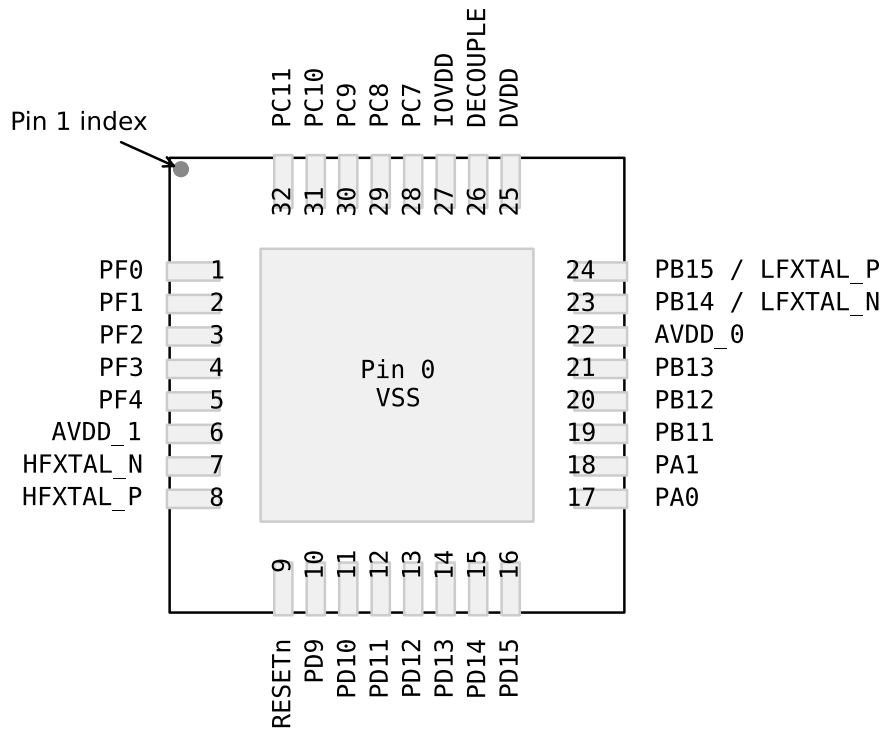

Figure 6.3. EFM32PG1 QFN32 without DC-DC Converter Pinout



Table 6.5. Device Pinout

QFN32 Pin# and Name		Pin Alternate Functionality / Description			
Pin #	Pin Name	Analog	Timers	Communication	Other
0	VREGVSS	Voltage regulator VSS			
1	PF0	BUSAX [ADC0: APORT1XCH16 ACMP0: APORT1XCH16 ACMP1: APORT1XCH16]  BUSBY [ADC0: APORT2YCH16 ACMP0: APORT2YCH16 ACMP1: APORT2YCH16]	TIM0_CC0 #24 TIM0_CC1 #23 TIM0_CC2 #22 TIM0_CDTI0 #21 TIM0_CDTI1 #20 TIM0_CDTI2 #19 TIM1_CC0 #24 TIM1_CC1 #23 TIM1_CC2 #22 TIM1_CC3 #21 LE- TIM0_OUT0 #24 LE- TIM0_OUT1 #23 PCNT0_S0IN #24 PCNT0_S1IN #23	US0_TX #24 US0_RX #23 US0_CLK #22 US0_CS #21 US0_CTS #20 US0_RTS #19 US1_TX #24 US1_RX #23 US1_CLK #22 US1_CS #21 US1_CTS #20 US1_RTS #19 LEU0_TX #24 LEU0_RX #23 I2C0_SDA #24 I2C0_SCL #23	PRS_CH0 #0 PRS_CH1 #7 PRS_CH2 #6 PRS_CH3 #5 ACMP0_O #24 ACMP1_O #24 DBG_SWCLKTCK #0 BOOT_TX
2	PF1	BUSAY [ADC0: APORT1YCH17 ACMP0: APORT1YCH17 ACMP1: APORT1YCH17]  BUSBX [ADC0: APORT2XCH17 ACMP0: APORT2XCH17 ACMP1: APORT2XCH17]	TIM0_CC0 #25 TIM0_CC1 #24 TIM0_CC2 #23 TIM0_CDTI0 #22 TIM0_CDTI1 #21 TIM0_CDTI2 #20 TIM1_CC0 #25 TIM1_CC1 #24 TIM1_CC2 #23 TIM1_CC3 #22 LE- TIM0_OUT0 #25 LE- TIM0_OUT1 #24 PCNT0_S0IN #25 PCNT0_S1IN #24	US0_TX #25 US0_RX #24 US0_CLK #23 US0_CS #22 US0_CTS #21 US0_RTS #20 US1_TX #25 US1_RX #24 US1_CLK #23 US1_CS #22 US1_CTS #21 US1_RTS #20 LEU0_TX #25 LEU0_RX #24 I2C0_SDA #25 I2C0_SCL #24	PRS_CH0 #1 PRS_CH1 #0 PRS_CH2 #7 PRS_CH3 #6 ACMP0_O #25 ACMP1_O #25 DBG_SWDIOTMS #0 BOOT_RX
3	PF2	BUSAX [ADC0: APORT1XCH18 ACMP0: APORT1XCH18 ACMP1: APORT1XCH18]  BUSBY [ADC0: APORT2YCH18 ACMP0: APORT2YCH18 ACMP1: APORT2YCH18]	TIM0_CC0 #26 TIM0_CC1 #25 TIM0_CC2 #24 TIM0_CDTI0 #23 TIM0_CDTI1 #22 TIM0_CDTI2 #21 TIM1_CC0 #26 TIM1_CC1 #25 TIM1_CC2 #24 TIM1_CC3 #23 LE- TIM0_OUT0 #26 LE- TIM0_OUT1 #25 PCNT0_S0IN #26 PCNT0_S1IN #25	US0_TX #26 US0_RX #25 US0_CLK #24 US0_CS #23 US0_CTS #22 US0_RTS #21 US1_TX #26 US1_RX #25 US1_CLK #24 US1_CS #23 US1_CTS #22 US1_RTS #21 LEU0_TX #26 LEU0_RX #25 I2C0_SDA #26 I2C0_SCL #25	CMU_CLK0 #6 PRS_CH0 #2 PRS_CH1 #1 PRS_CH2 #0 PRS_CH3 #7 ACMP0_O #26 ACMP1_O #26 DBG_TDO #0 DBG_SWO #0 GPIO_EM4WU0

QFN32 Pin# and Name		Pin Alternate Functionality / Description			
Pin #	Pin Name	Analog	Timers	Communication	Other
4	PF3	BUSAY [ADC0: APORT1YCH19 ACMP0: APORT1YCH19 ACMP1: APORT1YCH19]  BUSBX [ADC0: APORT2XCH19 ACMP0: APORT2XCH19 ACMP1: APORT2XCH19]	TIM0_CC0 #27 TIM0_CC1 #26 TIM0_CC2 #25 TIM0_CDTI0 #24 TIM0_CDTI1 #23 TIM0_CDTI2 #22 TIM1_CC0 #27 TIM1_CC1 #26 TIM1_CC2 #25 TIM1_CC3 #24 LE- TIM0_OUT0 #27 LE- TIM0_OUT1 #26 PCNT0_S0IN #27 PCNT0_S1IN #26	US0_TX #27 US0_RX #26 US0_CLK #25 US0_CS #24 US0_CTS #23 US0_RTS #22 US1_TX #27 US1_RX #26 US1_CLK #25 US1_CS #24 US1_CTS #23 US1_RTS #22 LEU0_TX #27 LEU0_RX #26 I2C0_SDA #27 I2C0_SCL #26	CMU_CLK1 #6 PRS_CH0 #3 PRS_CH1 #2 PRS_CH2 #1 PRS_CH3 #0 ACMP0_O #27 ACMP1_O #27 DBG_TDI #0
5	PF4	BUSAX [ADC0: APORT1XCH20 ACMP0: APORT1XCH20 ACMP1: APORT1XCH20]  BUSBY [ADC0: APORT2YCH20 ACMP0: APORT2YCH20 ACMP1: APORT2YCH20]	TIM0_CC0 #28 TIM0_CC1 #27 TIM0_CC2 #26 TIM0_CDTI0 #25 TIM0_CDTI1 #24 TIM0_CDTI2 #23 TIM1_CC0 #28 TIM1_CC1 #27 TIM1_CC2 #26 TIM1_CC3 #25 LE- TIM0_OUT0 #28 LE- TIM0_OUT1 #27 PCNT0_S0IN #28 PCNT0_S1IN #27	US0_TX #28 US0_RX #27 US0_CLK #26 US0_CS #25 US0_CTS #24 US0_RTS #23 US1_TX #28 US1_RX #27 US1_CLK #26 US1_CS #25 US1_CTS #24 US1_RTS #23 LEU0_TX #28 LEU0_RX #27 I2C0_SDA #28 I2C0_SCL #27	PRS_CH0 #4 PRS_CH1 #3 PRS_CH2 #2 PRS_CH3 #1 ACMP0_O #28 ACMP1_O #28
6	AVDD_1	Analog power supply 1.			
7	HFXTAL_N	High Frequency Crystal input pin.			
8	HFXTAL_P	High Frequency Crystal output pin.			
9	RESETn	Reset input, active low. To apply an external reset source to this pin, it is required to only drive this pin low during reset, and let the internal pull-up ensure that reset is released.			
10	PD9	BUSCY [ADC0: APORT3YCH1 ACMP0: APORT3YCH1 ACMP1: APORT3YCH1 IDAC0: APORT1YCH1]  BUSDX [ADC0: APORT4XCH1 ACMP0: APORT4XCH1 ACMP1: APORT4XCH1]	TIM0_CC0 #17 TIM0_CC1 #16 TIM0_CC2 #15 TIM0_CDTI0 #14 TIM0_CDTI1 #13 TIM0_CDTI2 #12 TIM1_CC0 #17 TIM1_CC1 #16 TIM1_CC2 #15 TIM1_CC3 #14 LE- TIM0_OUT0 #17 LE- TIM0_OUT1 #16 PCNT0_S0IN #17 PCNT0_S1IN #16	US0_TX #17 US0_RX #16 US0_CLK #15 US0_CS #14 US0_CTS #13 US0_RTS #12 US1_TX #17 US1_RX #16 US1_CLK #15 US1_CS #14 US1_CTS #13 US1_RTS #12 LEU0_TX #17 LEU0_RX #16 I2C0_SDA #17 I2C0_SCL #16	CMU_CLK0 #4 PRS_CH3 #8 PRS_CH4 #0 PRS_CH5 #6 PRS_CH6 #11 ACMP0_O #17 ACMP1_O #17

QFN32 Pin# and Name		Pin Alternate Functionality / Description			
Pin #	Pin Name	Analog	Timers	Communication	Other
11	PD10	<p>BUSCX [ADC0: APORT3XCH2 ACMP0: APORT3XCH2 ACMP1: APORT3XCH2 IDAC0: APORT1XCH2]</p> <p>BUSDY [ADC0: APORT4YCH2 ACMP0: APORT4YCH2 ACMP1: APORT4YCH2]</p>	<p>TIM0_CC0 #18 TIM0_CC1 #17 TIM0_CC2 #16 TIM0_CDTI0 #15 TIM0_CDTI1 #14 TIM0_CDTI2 #13 TIM1_CC0 #18 TIM1_CC1 #17 TIM1_CC2 #16 TIM1_CC3 #15 LE- TIM0_OUT0 #18 LE- TIM0_OUT1 #17 PCNT0_S0IN #18 PCNT0_S1IN #17</p>	<p>US0_TX #18 US0_RX #17 US0_CLK #16 US0_CS #15 US0_CTS #14 US0_RTS #13 US1_TX #18 US1_RX #17 US1_CLK #16 US1_CS #15 US1_CTS #14 US1_RTS #13 LEU0_TX #18 LEU0_RX #17 I2C0_SDA #18 I2C0_SCL #17</p>	<p>CMU_CLK1 #4 PRS_CH3 #9 PRS_CH4 #1 PRS_CH5 #0 PRS_CH6 #12 ACMP0_O #18 ACMP1_O #18</p>
12	PD11	<p>BUSCY [ADC0: APORT3YCH3 ACMP0: APORT3YCH3 ACMP1: APORT3YCH3 IDAC0: APORT1YCH3]</p> <p>BUSDX [ADC0: APORT4XCH3 ACMP0: APORT4XCH3 ACMP1: APORT4XCH3]</p>	<p>TIM0_CC0 #19 TIM0_CC1 #18 TIM0_CC2 #17 TIM0_CDTI0 #16 TIM0_CDTI1 #15 TIM0_CDTI2 #14 TIM1_CC0 #19 TIM1_CC1 #18 TIM1_CC2 #17 TIM1_CC3 #16 LE- TIM0_OUT0 #19 LE- TIM0_OUT1 #18 PCNT0_S0IN #19 PCNT0_S1IN #18</p>	<p>US0_TX #19 US0_RX #18 US0_CLK #17 US0_CS #16 US0_CTS #15 US0_RTS #14 US1_TX #19 US1_RX #18 US1_CLK #17 US1_CS #16 US1_CTS #15 US1_RTS #14 LEU0_TX #19 LEU0_RX #18 I2C0_SDA #19 I2C0_SCL #18</p>	<p>PRS_CH3 #10 PRS_CH4 #2 PRS_CH5 #1 PRS_CH6 #13 ACMP0_O #19 ACMP1_O #19</p>
13	PD12	<p>BUSCX [ADC0: APORT3XCH4 ACMP0: APORT3XCH4 ACMP1: APORT3XCH4 IDAC0: APORT1XCH4]</p> <p>BUSDY [ADC0: APORT4YCH4 ACMP0: APORT4YCH4 ACMP1: APORT4YCH4]</p>	<p>TIM0_CC0 #20 TIM0_CC1 #19 TIM0_CC2 #18 TIM0_CDTI0 #17 TIM0_CDTI1 #16 TIM0_CDTI2 #15 TIM1_CC0 #20 TIM1_CC1 #19 TIM1_CC2 #18 TIM1_CC3 #17 LE- TIM0_OUT0 #20 LE- TIM0_OUT1 #19 PCNT0_S0IN #20 PCNT0_S1IN #19</p>	<p>US0_TX #20 US0_RX #19 US0_CLK #18 US0_CS #17 US0_CTS #16 US0_RTS #15 US1_TX #20 US1_RX #19 US1_CLK #18 US1_CS #17 US1_CTS #16 US1_RTS #15 LEU0_TX #20 LEU0_RX #19 I2C0_SDA #20 I2C0_SCL #19</p>	<p>PRS_CH3 #11 PRS_CH4 #3 PRS_CH5 #2 PRS_CH6 #14 ACMP0_O #20 ACMP1_O #20</p>
14	PD13	<p>BUSCY [ADC0: APORT3YCH5 ACMP0: APORT3YCH5 ACMP1: APORT3YCH5 IDAC0: APORT1YCH5]</p> <p>BUSDX [ADC0: APORT4XCH5 ACMP0: APORT4XCH5 ACMP1: APORT4XCH5]</p>	<p>TIM0_CC0 #21 TIM0_CC1 #20 TIM0_CC2 #19 TIM0_CDTI0 #18 TIM0_CDTI1 #17 TIM0_CDTI2 #16 TIM1_CC0 #21 TIM1_CC1 #20 TIM1_CC2 #19 TIM1_CC3 #18 LE- TIM0_OUT0 #21 LE- TIM0_OUT1 #20 PCNT0_S0IN #21 PCNT0_S1IN #20</p>	<p>US0_TX #21 US0_RX #20 US0_CLK #19 US0_CS #18 US0_CTS #17 US0_RTS #16 US1_TX #21 US1_RX #20 US1_CLK #19 US1_CS #18 US1_CTS #17 US1_RTS #16 LEU0_TX #21 LEU0_RX #20 I2C0_SDA #21 I2C0_SCL #20</p>	<p>PRS_CH3 #12 PRS_CH4 #4 PRS_CH5 #3 PRS_CH6 #15 ACMP0_O #21 ACMP1_O #21</p>

QFN32 Pin# and Name		Pin Alternate Functionality / Description			
Pin #	Pin Name	Analog	Timers	Communication	Other
15	PD14	<p>BUSCX [ADC0: APORT3XCH6 ACMP0: APORT3XCH6 ACMP1: APORT3XCH6 IDAC0: APORT1XCH6]</p> <p>BUSDY [ADC0: APORT4YCH6 ACMP0: APORT4YCH6 ACMP1: APORT4YCH6]</p>	<p>TIM0_CC0 #22 TIM0_CC1 #21 TIM0_CC2 #20 TIM0_CDTI0 #19 TIM0_CDTI1 #18 TIM0_CDTI2 #17 TIM1_CC0 #22 TIM1_CC1 #21 TIM1_CC2 #20 TIM1_CC3 #19 LE- TIM0_OUT0 #22 LE- TIM0_OUT1 #21 PCNT0_S0IN #22 PCNT0_S1IN #21</p>	<p>US0_TX #22 US0_RX #21 US0_CLK #20 US0_CS #19 US0_CTS #18 US0_RTS #17 US1_TX #22 US1_RX #21 US1_CLK #20 US1_CS #19 US1_CTS #18 US1_RTS #17 LEU0_TX #22 LEU0_RX #21 I2C0_SDA #22 I2C0_SCL #21</p>	<p>CMU_CLK0 #5 PRS_CH3 #13 PRS_CH4 #5 PRS_CH5 #4 PRS_CH6 #16 ACMP0_O #22 ACMP1_O #22 GPIO_EM4WU4</p>
16	PD15	<p>BUSCY [ADC0: APORT3YCH7 ACMP0: APORT3YCH7 ACMP1: APORT3YCH7 IDAC0: APORT1YCH7]</p> <p>BUSDX [ADC0: APORT4XCH7 ACMP0: APORT4XCH7 ACMP1: APORT4XCH7]</p>	<p>TIM0_CC0 #23 TIM0_CC1 #22 TIM0_CC2 #21 TIM0_CDTI0 #20 TIM0_CDTI1 #19 TIM0_CDTI2 #18 TIM1_CC0 #23 TIM1_CC1 #22 TIM1_CC2 #21 TIM1_CC3 #20 LE- TIM0_OUT0 #23 LE- TIM0_OUT1 #22 PCNT0_S0IN #23 PCNT0_S1IN #22</p>	<p>US0_TX #23 US0_RX #22 US0_CLK #21 US0_CS #20 US0_CTS #19 US0_RTS #18 US1_TX #23 US1_RX #22 US1_CLK #21 US1_CS #20 US1_CTS #19 US1_RTS #18 LEU0_TX #23 LEU0_RX #22 I2C0_SDA #23 I2C0_SCL #22</p>	<p>CMU_CLK1 #5 PRS_CH3 #14 PRS_CH4 #6 PRS_CH5 #5 PRS_CH6 #17 ACMP0_O #23 ACMP1_O #23 DBG_SWO #2</p>
17	PA0	<p>ADC0_EXTN</p> <p>BUSCX [ADC0: APORT3XCH8 ACMP0: APORT3XCH8 ACMP1: APORT3XCH8 IDAC0: APORT1XCH8]</p> <p>BUSDY [ADC0: APORT4YCH8 ACMP0: APORT4YCH8 ACMP1: APORT4YCH8]</p>	<p>TIM0_CC0 #0 TIM0_CC1 #31 TIM0_CC2 #30 TIM0_CDTI0 #29 TIM0_CDTI1 #28 TIM0_CDTI2 #27 TIM1_CC0 #0 TIM1_CC1 #31 TIM1_CC2 #30 TIM1_CC3 #29 LE- TIM0_OUT0 #0 LE- TIM0_OUT1 #31 PCNT0_S0IN #0 PCNT0_S1IN #31</p>	<p>US0_TX #0 US0_RX #31 US0_CLK #30 US0_CS #29 US0_CTS #28 US0_RTS #27 US1_TX #0 US1_RX #31 US1_CLK #30 US1_CS #29 US1_CTS #28 US1_RTS #27 LEU0_TX #0 LEU0_RX #31 I2C0_SDA #0 I2C0_SCL #31</p>	<p>CMU_CLK1 #0 PRS_CH6 #0 PRS_CH7 #10 PRS_CH8 #9 PRS_CH9 #8 ACMP0_O #0 ACMP1_O #0</p>
18	PA1	<p>ADC0_EXTP</p> <p>BUSCY [ADC0: APORT3YCH9 ACMP0: APORT3YCH9 ACMP1: APORT3YCH9 IDAC0: APORT1YCH9]</p> <p>BUSDX [ADC0: APORT4XCH9 ACMP0: APORT4XCH9 ACMP1: APORT4XCH9]</p>	<p>TIM0_CC0 #1 TIM0_CC1 #0 TIM0_CC2 #31 TIM0_CDTI0 #30 TIM0_CDTI1 #29 TIM0_CDTI2 #28 TIM1_CC0 #1 TIM1_CC1 #0 TIM1_CC2 #31 TIM1_CC3 #30 LE- TIM0_OUT0 #1 LE- TIM0_OUT1 #0 PCNT0_S0IN #1 PCNT0_S1IN #0</p>	<p>US0_TX #1 US0_RX #0 US0_CLK #31 US0_CS #30 US0_CTS #29 US0_RTS #28 US1_TX #1 US1_RX #0 US1_CLK #31 US1_CS #30 US1_CTS #29 US1_RTS #28 LEU0_TX #1 LEU0_RX #0 I2C0_SDA #1 I2C0_SCL #0</p>	<p>CMU_CLK0 #0 PRS_CH6 #1 PRS_CH7 #0 PRS_CH8 #10 PRS_CH9 #9 ACMP0_O #1 ACMP1_O #1</p>

QFN32 Pin# and Name		Pin Alternate Functionality / Description			
Pin #	Pin Name	Analog	Timers	Communication	Other
19	PB11	<p>BUSCY [ADC0: APORT3YCH27 ACMP0: APORT3YCH27 ACMP1: APORT3YCH27 IDAC0: APORT1YCH27]</p> <p>BUSDY [ADC0: APORT4XCH27 ACMP0: APORT4XCH27 ACMP1: APORT4XCH27]</p>	<p>TIM0_CC0 #6 TIM0_CC1 #5 TIM0_CC2 #4 TIM0_CDTI0 #3 TIM0_CDTI1 #2 TIM0_CDTI2 #1 TIM1_CC0 #6 TIM1_CC1 #5 TIM1_CC2 #4 TIM1_CC3 #3 LE- TIM0_OUT0 #6 LE- TIM0_OUT1 #5 PCNT0_S0IN #6 PCNT0_S1IN #5</p>	<p>US0_TX #6 US0_RX #5 US0_CLK #4 US0_CS #3 US0_CTS #2 US0_RTS #1 US1_TX #6 US1_RX #5 US1_CLK #4 US1_CS #3 US1_CTS #2 US1_RTS #1 LEU0_TX #6 LEU0_RX #5 I2C0_SDA #6 I2C0_SCL #5</p>	<p>PRS_CH6 #6 PRS_CH7 #5 PRS_CH8 #4 PRS_CH9 #3 ACMP0_O #6 ACMP1_O #6</p>
20	PB12	<p>BUSCX [ADC0: APORT3XCH28 ACMP0: APORT3XCH28 ACMP1: APORT3XCH28 IDAC0: APORT1XCH28]</p> <p>BUSDY [ADC0: APORT4YCH28 ACMP0: APORT4YCH28 ACMP1: APORT4YCH28]</p>	<p>TIM0_CC0 #7 TIM0_CC1 #6 TIM0_CC2 #5 TIM0_CDTI0 #4 TIM0_CDTI1 #3 TIM0_CDTI2 #2 TIM1_CC0 #7 TIM1_CC1 #6 TIM1_CC2 #5 TIM1_CC3 #4 LE- TIM0_OUT0 #7 LE- TIM0_OUT1 #6 PCNT0_S0IN #7 PCNT0_S1IN #6</p>	<p>US0_TX #7 US0_RX #6 US0_CLK #5 US0_CS #4 US0_CTS #3 US0_RTS #2 US1_TX #7 US1_RX #6 US1_CLK #5 US1_CS #4 US1_CTS #3 US1_RTS #2 LEU0_TX #7 LEU0_RX #6 I2C0_SDA #7 I2C0_SCL #6</p>	<p>PRS_CH6 #7 PRS_CH7 #6 PRS_CH8 #5 PRS_CH9 #4 ACMP0_O #7 ACMP1_O #7</p>
21	PB13	<p>BUSCY [ADC0: APORT3YCH29 ACMP0: APORT3YCH29 ACMP1: APORT3YCH29 IDAC0: APORT1YCH29]</p> <p>BUSDY [ADC0: APORT4XCH29 ACMP0: APORT4XCH29 ACMP1: APORT4XCH29]</p>	<p>TIM0_CC0 #8 TIM0_CC1 #7 TIM0_CC2 #6 TIM0_CDTI0 #5 TIM0_CDTI1 #4 TIM0_CDTI2 #3 TIM1_CC0 #8 TIM1_CC1 #7 TIM1_CC2 #6 TIM1_CC3 #5 LE- TIM0_OUT0 #8 LE- TIM0_OUT1 #7 PCNT0_S0IN #8 PCNT0_S1IN #7</p>	<p>US0_TX #8 US0_RX #7 US0_CLK #6 US0_CS #5 US0_CTS #4 US0_RTS #3 US1_TX #8 US1_RX #7 US1_CLK #6 US1_CS #5 US1_CTS #4 US1_RTS #3 LEU0_TX #8 LEU0_RX #7 I2C0_SDA #8 I2C0_SCL #7</p>	<p>PRS_CH6 #8 PRS_CH7 #7 PRS_CH8 #6 PRS_CH9 #5 ACMP0_O #8 ACMP1_O #8 DBG_SWO #1 GPIO_EM4WU9</p>
22	AVDD_0	Analog power supply 0.			
23	PB14	<p>LFXTAL_N</p> <p>BUSCX [ADC0: APORT3XCH30 ACMP0: APORT3XCH30 ACMP1: APORT3XCH30 IDAC0: APORT1XCH30]</p> <p>BUSDY [ADC0: APORT4YCH30 ACMP0: APORT4YCH30 ACMP1: APORT4YCH30]</p>	<p>TIM0_CC0 #9 TIM0_CC1 #8 TIM0_CC2 #7 TIM0_CDTI0 #6 TIM0_CDTI1 #5 TIM0_CDTI2 #4 TIM1_CC0 #9 TIM1_CC1 #8 TIM1_CC2 #7 TIM1_CC3 #6 LE- TIM0_OUT0 #9 LE- TIM0_OUT1 #8 PCNT0_S0IN #9 PCNT0_S1IN #8</p>	<p>US0_TX #9 US0_RX #8 US0_CLK #7 US0_CS #6 US0_CTS #5 US0_RTS #4 US1_TX #9 US1_RX #8 US1_CLK #7 US1_CS #6 US1_CTS #5 US1_RTS #4 LEU0_TX #9 LEU0_RX #8 I2C0_SDA #9 I2C0_SCL #8</p>	<p>CMU_CLK1 #1 PRS_CH6 #9 PRS_CH7 #8 PRS_CH8 #7 PRS_CH9 #6 ACMP0_O #9 ACMP1_O #9</p>

QFN32 Pin# and Name		Pin Alternate Functionality / Description			
Pin #	Pin Name	Analog	Timers	Communication	Other
24	PB15	<p>LFXTAL_P</p> <p>BUSCY [ADC0: APORT3YCH31 ACMP0: APORT3YCH31 ACMP1: APORT3YCH31 IDAC0: APORT1YCH31]</p> <p>BUSDY [ADC0: APORT4XCH31 ACMP0: APORT4XCH31 ACMP1: APORT4XCH31]</p>	<p>TIM0_CC0 #10</p> <p>TIM0_CC1 #9</p> <p>TIM0_CC2 #8</p> <p>TIM0_CDTI0 #7</p> <p>TIM0_CDTI1 #6</p> <p>TIM0_CDTI2 #5</p> <p>TIM1_CC0 #10</p> <p>TIM1_CC1 #9</p> <p>TIM1_CC2 #8</p> <p>TIM1_CC3 #7 LE-</p> <p>TIM0_OUT0 #10 LE-</p> <p>TIM0_OUT1 #9</p> <p>PCNT0_S0IN #10</p> <p>PCNT0_S1IN #9</p>	<p>US0_TX #10 US0_RX #9 US0_CLK #8</p> <p>US0_CS #7 US0_CTS #6 US0_RTS #5</p> <p>US1_TX #10 US1_RX #9 US1_CLK #8</p> <p>US1_CS #7 US1_CTS #6 US1_RTS #5</p> <p>LEU0_TX #10 LEU0_RX #9 I2C0_SDA #10</p> <p>I2C0_SCL #9</p>	<p>CMU_CLK0 #1</p> <p>PRS_CH6 #10</p> <p>PRS_CH7 #9 PRS_CH8 #8 PRS_CH9 #7</p> <p>ACMP0_O #10</p> <p>ACMP1_O #10</p>
25	DVDD	Digital power supply.			
26	DECOUPLE	Decouple output for on-chip voltage regulator. An external capacitance of size C <sub>DECOUPLE</sub> is required at this pin.			
27	IOVDD	Digital IO power supply.			
28	PC7	<p>BUSAY [ADC0: APORT1YCH7 ACMP0: APORT1YCH7 ACMP1: APORT1YCH7]</p> <p>BUSBX [ADC0: APORT2XCH7 ACMP0: APORT2XCH7 ACMP1: APORT2XCH7]</p>	<p>TIM0_CC0 #12</p> <p>TIM0_CC1 #11</p> <p>TIM0_CC2 #10</p> <p>TIM0_CDTI0 #9</p> <p>TIM0_CDTI1 #8</p> <p>TIM0_CDTI2 #7</p> <p>TIM1_CC0 #12</p> <p>TIM1_CC1 #11</p> <p>TIM1_CC2 #10</p> <p>TIM1_CC3 #9 LE-</p> <p>TIM0_OUT0 #12 LE-</p> <p>TIM0_OUT1 #11</p> <p>PCNT0_S0IN #12</p> <p>PCNT0_S1IN #11</p>	<p>US0_TX #12 US0_RX #11 US0_CLK #10</p> <p>US0_CS #9 US0_CTS #8 US0_RTS #7</p> <p>US1_TX #12 US1_RX #11 US1_CLK #10</p> <p>US1_CS #9 US1_CTS #8 US1_RTS #7</p> <p>LEU0_TX #12 LEU0_RX #11 I2C0_SDA #12</p> <p>I2C0_SCL #11</p>	<p>CMU_CLK1 #2</p> <p>PRS_CH0 #9 PRS_CH9 #12 PRS_CH10 #1</p> <p>PRS_CH11 #0</p> <p>ACMP0_O #12</p> <p>ACMP1_O #12</p>
29	PC8	<p>BUSAX [ADC0: APORT1XCH8 ACMP0: APORT1XCH8 ACMP1: APORT1XCH8]</p> <p>BUSBY [ADC0: APORT2YCH8 ACMP0: APORT2YCH8 ACMP1: APORT2YCH8]</p>	<p>TIM0_CC0 #13</p> <p>TIM0_CC1 #12</p> <p>TIM0_CC2 #11</p> <p>TIM0_CDTI0 #10</p> <p>TIM0_CDTI1 #9</p> <p>TIM0_CDTI2 #8</p> <p>TIM1_CC0 #13</p> <p>TIM1_CC1 #12</p> <p>TIM1_CC2 #11</p> <p>TIM1_CC3 #10 LE-</p> <p>TIM0_OUT0 #13 LE-</p> <p>TIM0_OUT1 #12</p> <p>PCNT0_S0IN #13</p> <p>PCNT0_S1IN #12</p>	<p>US0_TX #13 US0_RX #12 US0_CLK #11</p> <p>US0_CS #10 US0_CTS #9 US0_RTS #8</p> <p>US1_TX #13 US1_RX #12 US1_CLK #11</p> <p>US1_CS #10 US1_CTS #9 US1_RTS #8</p> <p>LEU0_TX #13 LEU0_RX #12 I2C0_SDA #13</p> <p>I2C0_SCL #12</p>	<p>PRS_CH0 #10</p> <p>PRS_CH9 #13</p> <p>PRS_CH10 #2</p> <p>PRS_CH11 #1</p> <p>ACMP0_O #13</p> <p>ACMP1_O #13</p>

QFN32 Pin# and Name		Pin Alternate Functionality / Description			
Pin #	Pin Name	Analog	Timers	Communication	Other
30	PC9	BUSAY [ADC0: APORT1YCH9 ACMP0: APORT1YCH9 ACMP1: APORT1YCH9]  BUSBX [ADC0: APORT2XCH9 ACMP0: APORT2XCH9 ACMP1: APORT2XCH9]	TIM0_CC0 #14 TIM0_CC1 #13 TIM0_CC2 #12 TIM0_CDTI0 #11 TIM0_CDTI1 #10 TIM0_CDTI2 #9 TIM1_CC0 #14 TIM1_CC1 #13 TIM1_CC2 #12 TIM1_CC3 #11 LE- TIMO_OUT0 #14 LE- TIMO_OUT1 #13 PCNT0_S0IN #14 PCNT0_S1IN #13	US0_TX #14 US0_RX #13 US0_CLK #12 US0_CS #11 US0_CTS #10 US0_RTS #9 US1_TX #14 US1_RX #13 US1_CLK #12 US1_CS #11 US1_CTS #10 US1_RTS #9 LEU0_TX #14 LEU0_RX #13 I2C0_SDA #14 I2C0_SCL #13	PRS_CH0 #11 PRS_CH9 #14 PRS_CH10 #3 PRS_CH11 #2 ACMP0_O #14 ACMP1_O #14
31	PC10	BUSAX [ADC0: APORT1XCH10 ACMP0: APORT1XCH10 ACMP1: APORT1XCH10]  BUSBY [ADC0: APORT2YCH10 ACMP0: APORT2YCH10 ACMP1: APORT2YCH10]	TIM0_CC0 #15 TIM0_CC1 #14 TIM0_CC2 #13 TIM0_CDTI0 #12 TIM0_CDTI1 #11 TIM0_CDTI2 #10 TIM1_CC0 #15 TIM1_CC1 #14 TIM1_CC2 #13 TIM1_CC3 #12 LE- TIMO_OUT0 #15 LE- TIMO_OUT1 #14 PCNT0_S0IN #15 PCNT0_S1IN #14	US0_TX #15 US0_RX #14 US0_CLK #13 US0_CS #12 US0_CTS #11 US0_RTS #10 US1_TX #15 US1_RX #14 US1_CLK #13 US1_CS #12 US1_CTS #11 US1_RTS #10 LEU0_TX #15 LEU0_RX #14 I2C0_SDA #15 I2C0_SCL #14	CMU_CLK1 #3 PRS_CH0 #12 PRS_CH9 #15 PRS_CH10 #4 PRS_CH11 #3 ACMP0_O #15 ACMP1_O #15 GPIO_EM4WU12
32	PC11	BUSAY [ADC0: APORT1YCH11 ACMP0: APORT1YCH11 ACMP1: APORT1YCH11]  BUSBX [ADC0: APORT2XCH11 ACMP0: APORT2XCH11 ACMP1: APORT2XCH11]	TIM0_CC0 #16 TIM0_CC1 #15 TIM0_CC2 #14 TIM0_CDTI0 #13 TIM0_CDTI1 #12 TIM0_CDTI2 #11 TIM1_CC0 #16 TIM1_CC1 #15 TIM1_CC2 #14 TIM1_CC3 #13 LE- TIMO_OUT0 #16 LE- TIMO_OUT1 #15 PCNT0_S0IN #16 PCNT0_S1IN #15	US0_TX #16 US0_RX #15 US0_CLK #14 US0_CS #13 US0_CTS #12 US0_RTS #11 US1_TX #16 US1_RX #15 US1_CLK #14 US1_CS #13 US1_CTS #12 US1_RTS #11 LEU0_TX #16 LEU0_RX #15 I2C0_SDA #16 I2C0_SCL #15	CMU_CLK0 #3 PRS_CH0 #13 PRS_CH9 #16 PRS_CH10 #5 PRS_CH11 #4 ACMP0_O #16 ACMP1_O #16 DBG_SWO #3

### 6.3.1 GPIO Pinout Overview

The GPIO pins are organized as 16-bit ports indicated by letters A through F, and the individual pins on each port is indicated by a number from 15 down to 0.

**Table 6.6. GPIO Pinout**

Port	Pin 15	Pin 14	Pin 13	Pin 12	Pin 11	Pin 10	Pin 9	Pin 8	Pin 7	Pin 6	Pin 5	Pin 4	Pin 3	Pin 2	Pin 1	Pin 0
Port A	-	-	-	-	-	-	-	-	-	-	-	-	-	-	PA1	PA0
Port B	PB15	PB14	PB13 (5V)	PB12 (5V)	PB11 (5V)	-	-	-	-	-	-	-	-	-	-	-
Port C	-	-	-	-	PC11 (5V)	PC10 (5V)	PC9 (5V)	PC8 (5V)	PC7 (5V)	-	-	-	-	-	-	-
Port D	PD15 (5V)	PD14 (5V)	PD13 (5V)	PD12 (5V)	PD11 (5V)	PD10 (5V)	PD9 (5V)	-	-	-	-	-	-	-	-	-
Port E	-	-	-	-	-	-	-	-	-	-	-	-	-	-	-	-
Port F	-	-	-	-	-	-	-	-	-	-	-	PF4 (5V)	PF3 (5V)	PF2 (5V)	PF1 (5V)	PF0 (5V)



## 6.4 Alternate Functionality Pinout

A wide selection of alternate functionality is available for multiplexing to various pins. The following table shows the name of the alternate functionality in the first column, followed by columns showing the possible LOCATION bitfield settings.

**Note:** Some functionality, such as analog interfaces, do not have alternate settings or a LOCATION bitfield. In these cases, the pinout is shown in the column corresponding to LOCATION 0.

**Table 6.7. Alternate functionality overview**

Alternate Functionality	LOCATION								Description
	0 - 3	4 - 7	8 - 11	12 - 15	16 - 19	20 - 23	24 - 27	28 - 31	
ACMP0_O	0: PA0 1: PA1 2: PA2 3: PA3	4: PA4 5: PA5 6: PB11 7: PB12	8: PB13 9: PB14 10: PB15 11: PC6	12: PC7 13: PC8 14: PC9 15: PC10	16: PC11 17: PD9 18: PD10 19: PD11	20: PD12 21: PD13 22: PD14 23: PD15	24: PF0 25: PF1 26: PF2 27: PF3	28: PF4 29: PF5 30: PF6 31: PF7	Analog comparator ACMP0, digital output.
ACMP1_O	0: PA0 1: PA1 2: PA2 3: PA3	4: PA4 5: PA5 6: PB11 7: PB12	8: PB13 9: PB14 10: PB15 11: PC6	12: PC7 13: PC8 14: PC9 15: PC10	16: PC11 17: PD9 18: PD10 19: PD11	20: PD12 21: PD13 22: PD14 23: PD15	24: PF0 25: PF1 26: PF2 27: PF3	28: PF4 29: PF5 30: PF6 31: PF7	Analog comparator ACMP1, digital output.
ADC0_EXTN	0: PA0								Analog to digital converter ADC0 external reference input negative pin
ADC0_EXTP	0: PA1								Analog to digital converter ADC0 external reference input positive pin
BOOT_RX	0: PF1								Bootloader RX
BOOT_TX	0: PF0								Bootloader TX
CMU_CLK0	0: PA1 1: PB15 2: PC6 3: PC11	4: PD9 5: PD14 6: PF2 7: PF7							Clock Management Unit, clock output number 0.
CMU_CLK1	0: PA0 1: PB14 2: PC7 3: PC10	4: PD10 5: PD15 6: PF3 7: PF6							Clock Management Unit, clock output number 1.
DBG_SWCLKTCK	0: PF0								Debug-interface Serial Wire clock input and JTAG Test Clock.  Note that this function is enabled to the pin out of reset, and has a built-in pull down.

Alternate	LOCATION								Description
	0 - 3	4 - 7	8 - 11	12 - 15	16 - 19	20 - 23	24 - 27	28 - 31	
DBG_SWDIOTMS	0: PF1								<p>Debug-interface Serial Wire data input / output and JTAG Test Mode Select.</p> <p>Note that this function is enabled to the pin out of reset, and has a built-in pull up.</p>
DBG_SWO	0: PF2 1: PB13 2: PD15 3: PC11								<p>Debug-interface Serial Wire viewer Output.</p> <p>Note that this function is not enabled after reset, and must be enabled by software to be used.</p>
DBG_TDI	0: PF3								<p>Debug-interface JTAG Test Data In.</p> <p>Note that this function is enabled to pin out of reset, and has a built-in pull up.</p>
DBG_TDO	0: PF2								<p>Debug-interface JTAG Test Data Out.</p> <p>Note that this function is enabled to pin out of reset.</p>
GPIO_EM4WU0	0: PF2								Pin can be used to wake the system up from EM4
GPIO_EM4WU1	0: PF7								Pin can be used to wake the system up from EM4
GPIO_EM4WU4	0: PD14								Pin can be used to wake the system up from EM4
GPIO_EM4WU8	0: PA3								Pin can be used to wake the system up from EM4
GPIO_EM4WU9	0: PB13								Pin can be used to wake the system up from EM4

Alternate	LOCATION								Description
	0 - 3	4 - 7	8 - 11	12 - 15	16 - 19	20 - 23	24 - 27	28 - 31	
GPIO_EM4WU12	0: PC10								Pin can be used to wake the system up from EM4
I2C0_SCL	0: PA1 1: PA2 2: PA3 3: PA4	4: PA5 5: PB11 6: PB12 7: PB13	8: PB14 9: PB15 10: PC6 11: PC7	12: PC8 13: PC9 14: PC10 15: PC11	16: PD9 17: PD10 18: PD11 19: PD12	20: PD13 21: PD14 22: PD15 23: PF0	24: PF1 25: PF2 26: PF3 27: PF4	28: PF5 29: PF6 30: PF7 31: PA0	I2C0 Serial Clock Line input / output.
I2C0_SDA	0: PA0 1: PA1 2: PA2 3: PA3	4: PA4 5: PA5 6: PB11 7: PB12	8: PB13 9: PB14 10: PB15 11: PC6	12: PC7 13: PC8 14: PC9 15: PC10	16: PC11 17: PD9 18: PD10 19: PD11	20: PD12 21: PD13 22: PD14 23: PD15	24: PF0 25: PF1 26: PF2 27: PF3	28: PF4 29: PF5 30: PF6 31: PF7	I2C0 Serial Data input / output.
LETIM0_OUT0	0: PA0 1: PA1 2: PA2 3: PA3	4: PA4 5: PA5 6: PB11 7: PB12	8: PB13 9: PB14 10: PB15 11: PC6	12: PC7 13: PC8 14: PC9 15: PC10	16: PC11 17: PD9 18: PD10 19: PD11	20: PD12 21: PD13 22: PD14 23: PD15	24: PF0 25: PF1 26: PF2 27: PF3	28: PF4 29: PF5 30: PF6 31: PF7	Low Energy Timer LETIM0, output channel 0.
LETIM0_OUT1	0: PA1 1: PA2 2: PA3 3: PA4	4: PA5 5: PB11 6: PB12 7: PB13	8: PB14 9: PB15 10: PC6 11: PC7	12: PC8 13: PC9 14: PC10 15: PC11	16: PD9 17: PD10 18: PD11 19: PD12	20: PD13 21: PD14 22: PD15 23: PF0	24: PF1 25: PF2 26: PF3 27: PF4	28: PF5 29: PF6 30: PF7 31: PA0	Low Energy Timer LETIM0, output channel 1.
LEU0_RX	0: PA1 1: PA2 2: PA3 3: PA4	4: PA5 5: PB11 6: PB12 7: PB13	8: PB14 9: PB15 10: PC6 11: PC7	12: PC8 13: PC9 14: PC10 15: PC11	16: PD9 17: PD10 18: PD11 19: PD12	20: PD13 21: PD14 22: PD15 23: PF0	24: PF1 25: PF2 26: PF3 27: PF4	28: PF5 29: PF6 30: PF7 31: PA0	LEUART0 Receive input.
LEU0_TX	0: PA0 1: PA1 2: PA2 3: PA3	4: PA4 5: PA5 6: PB11 7: PB12	8: PB13 9: PB14 10: PB15 11: PC6	12: PC7 13: PC8 14: PC9 15: PC10	16: PC11 17: PD9 18: PD10 19: PD11	20: PD12 21: PD13 22: PD14 23: PD15	24: PF0 25: PF1 26: PF2 27: PF3	28: PF4 29: PF5 30: PF6 31: PF7	LEUART0 Transmit output. Also used as receive input in half duplex communication.
LFXTAL_N	0: PB14								Low Frequency Crystal (typically 32.768 kHz) negative pin. Also used as an optional external clock input pin.
LFXTAL_P	0: PB15								Low Frequency Crystal (typically 32.768 kHz) positive pin.
PCNT0_S0IN	0: PA0 1: PA1 2: PA2 3: PA3	4: PA4 5: PA5 6: PB11 7: PB12	8: PB13 9: PB14 10: PB15 11: PC6	12: PC7 13: PC8 14: PC9 15: PC10	16: PC11 17: PD9 18: PD10 19: PD11	20: PD12 21: PD13 22: PD14 23: PD15	24: PF0 25: PF1 26: PF2 27: PF3	28: PF4 29: PF5 30: PF6 31: PF7	Pulse Counter PCNT0 input number 0.
PCNT0_S1IN	0: PA1 1: PA2 2: PA3 3: PA4	4: PA5 5: PB11 6: PB12 7: PB13	8: PB14 9: PB15 10: PC6 11: PC7	12: PC8 13: PC9 14: PC10 15: PC11	16: PD9 17: PD10 18: PD11 19: PD12	20: PD13 21: PD14 22: PD15 23: PF0	24: PF1 25: PF2 26: PF3 27: PF4	28: PF5 29: PF6 30: PF7 31: PA0	Pulse Counter PCNT0 input number 1.
PRS_CH0	0: PF0 1: PF1 2: PF2 3: PF3	4: PF4 5: PF5 6: PF6 7: PF7	8: PC6 9: PC7 10: PC8 11: PC9	12: PC10 13: PC11					Peripheral Reflex System PRS, channel 0.

Alternate	LOCATION								
Functionality	0 - 3	4 - 7	8 - 11	12 - 15	16 - 19	20 - 23	24 - 27	28 - 31	Description
PRS_CH1	0: PF1 1: PF2 2: PF3 3: PF4	4: PF5 5: PF6 6: PF7 7: PF0							Peripheral Reflex System PRS, channel 1.
PRS_CH2	0: PF2 1: PF3 2: PF4 3: PF5	4: PF6 5: PF7 6: PF0 7: PF1							Peripheral Reflex System PRS, channel 2.
PRS_CH3	0: PF3 1: PF4 2: PF5 3: PF6	4: PF7 5: PF0 6: PF1 7: PF2	8: PD9 9: PD10 10: PD11 11: PD12	12: PD13 13: PD14 14: PD15					Peripheral Reflex System PRS, channel 3.
PRS_CH4	0: PD9 1: PD10 2: PD11 3: PD12	4: PD13 5: PD14 6: PD15							Peripheral Reflex System PRS, channel 4.
PRS_CH5	0: PD10 1: PD11 2: PD12 3: PD13	4: PD14 5: PD15 6: PD9							Peripheral Reflex System PRS, channel 5.
PRS_CH6	0: PA0 1: PA1 2: PA2 3: PA3	4: PA4 5: PA5 6: PB11 7: PB12	8: PB13 9: PB14 10: PB15 11: PD9	12: PD10 13: PD11 14: PD12 15: PD13	16: PD14 17: PD15				Peripheral Reflex System PRS, channel 6.
PRS_CH7	0: PA1 1: PA2 2: PA3 3: PA4	4: PA5 5: PB11 6: PB12 7: PB13	8: PB14 9: PB15 10: PA0						Peripheral Reflex System PRS, channel 7.
PRS_CH8	0: PA2 1: PA3 2: PA4 3: PA5	4: PB11 5: PB12 6: PB13 7: PB14	8: PB15 9: PA0 10: PA1						Peripheral Reflex System PRS, channel 8.
PRS_CH9	0: PA3 1: PA4 2: PA5 3: PB11	4: PB12 5: PB13 6: PB14 7: PB15	8: PA0 9: PA1 10: PA2 11: PC6	12: PC7 13: PC8 14: PC9 15: PC10	16: PC11				Peripheral Reflex System PRS, channel 9.
PRS_CH10	0: PC6 1: PC7 2: PC8 3: PC9	4: PC10 5: PC11							Peripheral Reflex System PRS, channel 10.
PRS_CH11	0: PC7 1: PC8 2: PC9 3: PC10	4: PC11 5: PC6							Peripheral Reflex System PRS, channel 11.
TIM0_CC0	0: PA0 1: PA1 2: PA2 3: PA3	4: PA4 5: PA5 6: PB11 7: PB12	8: PB13 9: PB14 10: PB15 11: PC6	12: PC7 13: PC8 14: PC9 15: PC10	16: PC11 17: PD9 18: PD10 19: PD11	20: PD12 21: PD13 22: PD14 23: PD15	24: PF0 25: PF1 26: PF2 27: PF3	28: PF4 29: PF5 30: PF6 31: PF7	Timer 0 Capture Compare input / output channel 0.
TIM0_CC1	0: PA1 1: PA2 2: PA3 3: PA4	4: PA5 5: PB11 6: PB12 7: PB13	8: PB14 9: PB15 10: PC6 11: PC7	12: PC8 13: PC9 14: PC10 15: PC11	16: PD9 17: PD10 18: PD11 19: PD12	20: PD13 21: PD14 22: PD15 23: PF0	24: PF1 25: PF2 26: PF3 27: PF4	28: PF5 29: PF6 30: PF7 31: PA0	Timer 0 Capture Compare input / output channel 1.

Alternate	LOCATION								
Functionality	0 - 3	4 - 7	8 - 11	12 - 15	16 - 19	20 - 23	24 - 27	28 - 31	Description
TIM0_CC2	0: PA2 1: PA3 2: PA4 3: PA5	4: PB11 5: PB12 6: PB13 7: PB14	8: PB15 9: PC6 10: PC7 11: PC8	12: PC9 13: PC10 14: PC11 15: PD9	16: PD10 17: PD11 18: PD12 19: PD13	20: PD14 21: PD15 22: PF0 23: PF1	24: PF2 25: PF3 26: PF4 27: PF5	28: PF6 29: PF7 30: PA0 31: PA1	Timer 0 Capture Compare input / output channel 2.
TIM0_CDT10	0: PA3 1: PA4 2: PA5 3: PB11	4: PB12 5: PB13 6: PB14 7: PB15	8: PC6 9: PC7 10: PC8 11: PC9	12: PC10 13: PC11 14: PD9 15: PD10	16: PD11 17: PD12 18: PD13 19: PD14	20: PD15 21: PF0 22: PF1 23: PF2	24: PF3 25: PF4 26: PF5 27: PF6	28: PF7 29: PA0 30: PA1 31: PA2	Timer 0 Complimentary Dead Time Insertion channel 0.
TIM0_CDT11	0: PA4 1: PA5 2: PB11 3: PB12	4: PB13 5: PB14 6: PB15 7: PC6	8: PC7 9: PC8 10: PC9 11: PC10	12: PC11 13: PD9 14: PD10 15: PD11	16: PD12 17: PD13 18: PD14 19: PD15	20: PF0 21: PF1 22: PF2 23: PF3	24: PF4 25: PF5 26: PF6 27: PF7	28: PA0 29: PA1 30: PA2 31: PA3	Timer 0 Complimentary Dead Time Insertion channel 1.
TIM0_CDT12	0: PA5 1: PB11 2: PB12 3: PB13	4: PB14 5: PB15 6: PC6 7: PC7	8: PC8 9: PC9 10: PC10 11: PC11	12: PD9 13: PD10 14: PD11 15: PD12	16: PD13 17: PD14 18: PD15 19: PF0	20: PF1 21: PF2 22: PF3 23: PF4	24: PF5 25: PF6 26: PF7 27: PA0	28: PA1 29: PA2 30: PA3 31: PA4	Timer 0 Complimentary Dead Time Insertion channel 2.
TIM1_CC0	0: PA0 1: PA1 2: PA2 3: PA3	4: PA4 5: PA5 6: PB11 7: PB12	8: PB13 9: PB14 10: PB15 11: PC6	12: PC7 13: PC8 14: PC9 15: PC10	16: PC11 17: PD9 18: PD10 19: PD11	20: PD12 21: PD13 22: PD14 23: PD15	24: PF0 25: PF1 26: PF2 27: PF3	28: PF4 29: PF5 30: PF6 31: PF7	Timer 1 Capture Compare input / output channel 0.
TIM1_CC1	0: PA1 1: PA2 2: PA3 3: PA4	4: PA5 5: PB11 6: PB12 7: PB13	8: PB14 9: PB15 10: PC6 11: PC7	12: PC8 13: PC9 14: PC10 15: PC11	16: PD9 17: PD10 18: PD11 19: PD12	20: PD13 21: PD14 22: PD15 23: PF0	24: PF1 25: PF2 26: PF3 27: PF4	28: PF5 29: PF6 30: PF7 31: PA0	Timer 1 Capture Compare input / output channel 1.
TIM1_CC2	0: PA2 1: PA3 2: PA4 3: PA5	4: PB11 5: PB12 6: PB13 7: PB14	8: PB15 9: PC6 10: PC7 11: PC8	12: PC9 13: PC10 14: PC11 15: PD9	16: PD10 17: PD11 18: PD12 19: PD13	20: PD14 21: PD15 22: PF0 23: PF1	24: PF2 25: PF3 26: PF4 27: PF5	28: PF6 29: PF7 30: PA0 31: PA1	Timer 1 Capture Compare input / output channel 2.
TIM1_CC3	0: PA3 1: PA4 2: PA5 3: PB11	4: PB12 5: PB13 6: PB14 7: PB15	8: PC6 9: PC7 10: PC8 11: PC9	12: PC10 13: PC11 14: PD9 15: PD10	16: PD11 17: PD12 18: PD13 19: PD14	20: PD15 21: PF0 22: PF1 23: PF2	24: PF3 25: PF4 26: PF5 27: PF6	28: PF7 29: PA0 30: PA1 31: PA2	Timer 1 Capture Compare input / output channel 3.
US0_CLK	0: PA2 1: PA3 2: PA4 3: PA5	4: PB11 5: PB12 6: PB13 7: PB14	8: PB15 9: PC6 10: PC7 11: PC8	12: PC9 13: PC10 14: PC11 15: PD9	16: PD10 17: PD11 18: PD12 19: PD13	20: PD14 21: PD15 22: PF0 23: PF1	24: PF2 25: PF3 26: PF4 27: PF5	28: PF6 29: PF7 30: PA0 31: PA1	USART0 clock input / output.
US0_CS	0: PA3 1: PA4 2: PA5 3: PB11	4: PB12 5: PB13 6: PB14 7: PB15	8: PC6 9: PC7 10: PC8 11: PC9	12: PC10 13: PC11 14: PD9 15: PD10	16: PD11 17: PD12 18: PD13 19: PD14	20: PD15 21: PF0 22: PF1 23: PF2	24: PF3 25: PF4 26: PF5 27: PF6	28: PF7 29: PA0 30: PA1 31: PA2	USART0 chip select input / output.
US0_CTS	0: PA4 1: PA5 2: PB11 3: PB12	4: PB13 5: PB14 6: PB15 7: PC6	8: PC7 9: PC8 10: PC9 11: PC10	12: PC11 13: PD9 14: PD10 15: PD11	16: PD12 17: PD13 18: PD14 19: PD15	20: PF0 21: PF1 22: PF2 23: PF3	24: PF4 25: PF5 26: PF6 27: PF7	28: PA0 29: PA1 30: PA2 31: PA3	USART0 Clear To Send hardware flow control input.
US0_RTS	0: PA5 1: PB11 2: PB12 3: PB13	4: PB14 5: PB15 6: PC6 7: PC7	8: PC8 9: PC9 10: PC10 11: PC11	12: PD9 13: PD10 14: PD11 15: PD12	16: PD13 17: PD14 18: PD15 19: PF0	20: PF1 21: PF2 22: PF3 23: PF4	24: PF5 25: PF6 26: PF7 27: PA0	28: PA1 29: PA2 30: PA3 31: PA4	USART0 Request To Send hardware flow control output.

Alternate	LOCATION								
Functionality	0 - 3	4 - 7	8 - 11	12 - 15	16 - 19	20 - 23	24 - 27	28 - 31	Description
US0_RX	0: PA1 1: PA2 2: PA3 3: PA4	4: PA5 5: PB11 6: PB12 7: PB13	8: PB14 9: PB15 10: PC6 11: PC7	12: PC8 13: PC9 14: PC10 15: PC11	16: PD9 17: PD10 18: PD11 19: PD12	20: PD13 21: PD14 22: PD15 23: PF0	24: PF1 25: PF2 26: PF3 27: PF4	28: PF5 29: PF6 30: PF7 31: PA0	USART0 Asynchronous Receive.  USART0 Synchronous mode Master Input / Slave Output (MISO).
US0_TX	0: PA0 1: PA1 2: PA2 3: PA3	4: PA4 5: PA5 6: PB11 7: PB12	8: PB13 9: PB14 10: PB15 11: PC6	12: PC7 13: PC8 14: PC9 15: PC10	16: PC11 17: PD9 18: PD10 19: PD11	20: PD12 21: PD13 22: PD14 23: PD15	24: PF0 25: PF1 26: PF2 27: PF3	28: PF4 29: PF5 30: PF6 31: PF7	USART0 Asynchronous Transmit. Also used as receive input in half duplex communication.  USART0 Synchronous mode Master Output / Slave Input (MOSI).
US1_CLK	0: PA2 1: PA3 2: PA4 3: PA5	4: PB11 5: PB12 6: PB13 7: PB14	8: PB15 9: PC6 10: PC7 11: PC8	12: PC9 13: PC10 14: PC11 15: PD9	16: PD10 17: PD11 18: PD12 19: PD13	20: PD14 21: PD15 22: PF0 23: PF1	24: PF2 25: PF3 26: PF4 27: PF5	28: PF6 29: PF7 30: PA0 31: PA1	USART1 clock input / output.
US1_CS	0: PA3 1: PA4 2: PA5 3: PB11	4: PB12 5: PB13 6: PB14 7: PB15	8: PC6 9: PC7 10: PC8 11: PC9	12: PC10 13: PC11 14: PD9 15: PD10	16: PD11 17: PD12 18: PD13 19: PD14	20: PD15 21: PF0 22: PF1 23: PF2	24: PF3 25: PF4 26: PF5 27: PF6	28: PF7 29: PA0 30: PA1 31: PA2	USART1 chip select input / output.
US1_CTS	0: PA4 1: PA5 2: PB11 3: PB12	4: PB13 5: PB14 6: PB15 7: PC6	8: PC7 9: PC8 10: PC9 11: PC10	12: PC11 13: PD9 14: PD10 15: PD11	16: PD12 17: PD13 18: PD14 19: PD15	20: PF0 21: PF1 22: PF2 23: PF3	24: PF4 25: PF5 26: PF6 27: PF7	28: PA0 29: PA1 30: PA2 31: PA3	USART1 Clear To Send hardware flow control input.
US1_RTS	0: PA5 1: PB11 2: PB12 3: PB13	4: PB14 5: PB15 6: PC6 7: PC7	8: PC8 9: PC9 10: PC10 11: PC11	12: PD9 13: PD10 14: PD11 15: PD12	16: PD13 17: PD14 18: PD15 19: PF0	20: PF1 21: PF2 22: PF3 23: PF4	24: PF5 25: PF6 26: PF7 27: PA0	28: PA1 29: PA2 30: PA3 31: PA4	USART1 Request To Send hardware flow control output.
US1_RX	0: PA1 1: PA2 2: PA3 3: PA4	4: PA5 5: PB11 6: PB12 7: PB13	8: PB14 9: PB15 10: PC6 11: PC7	12: PC8 13: PC9 14: PC10 15: PC11	16: PD9 17: PD10 18: PD11 19: PD12	20: PD13 21: PD14 22: PD15 23: PF0	24: PF1 25: PF2 26: PF3 27: PF4	28: PF5 29: PF6 30: PF7 31: PA0	USART1 Asynchronous Receive.  USART1 Synchronous mode Master Input / Slave Output (MISO).
US1_TX	0: PA0 1: PA1 2: PA2 3: PA3	4: PA4 5: PA5 6: PB11 7: PB12	8: PB13 9: PB14 10: PB15 11: PC6	12: PC7 13: PC8 14: PC9 15: PC10	16: PC11 17: PD9 18: PD10 19: PD11	20: PD12 21: PD13 22: PD14 23: PD15	24: PF0 25: PF1 26: PF2 27: PF3	28: PF4 29: PF5 30: PF6 31: PF7	USART1 Asynchronous Transmit. Also used as receive input in half duplex communication.  USART1 Synchronous mode Master Output / Slave Input (MOSI).

## 6.5 Analog Port (APORT)

The Analog Port (APORT) is an infrastructure used to connect chip pins with on-chip analog clients such as analog comparators, ADCs, and DACs. The APORT consists of wires, switches, and control needed to configurably implement the routes. Please see the device Reference Manual for a complete description.

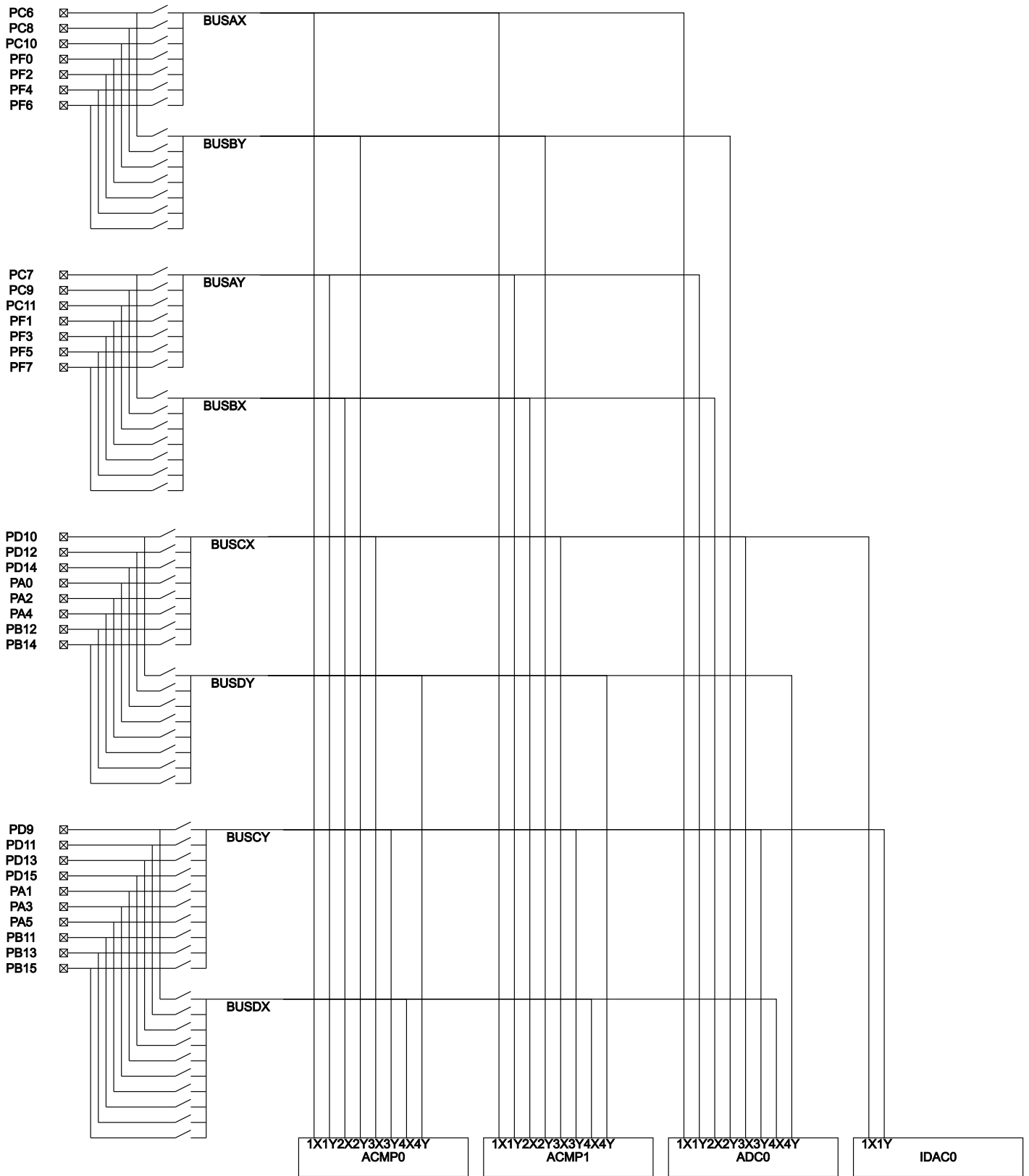

Figure 6.4. EFM32PG1 APORT



**Table 6.8. APORT Client Map**

Analog Module	Analog Module Channel	Shared Bus	Pin
ACMP0	APORT1XCH6	BUSAX	PC6
	APORT1XCH8		PC8
	APORT1XCH10		PC10
	APORT1XCH16		PF0
	APORT1XCH18		PF2
	APORT1XCH20		PF4
	APORT1XCH22		PF6
ACMP0	APORT1YCH7	BUSAY	PC7
	APORT1YCH9		PC9
	APORT1YCH11		PC11
	APORT1YCH17		PF1
	APORT1YCH19		PF3
	APORT1YCH21		PF5
	APORT1YCH23		PF7
ACMP0	APORT2XCH7	BUSBX	PC7
	APORT2XCH9		PC9
	APORT2XCH11		PC11
	APORT2XCH17		PF1
	APORT2XCH19		PF3
	APORT2XCH21		PF5
	APORT2XCH23		PF7
ACMP0	APORT2YCH6	BUSBY	PC6
	APORT2YCH8		PC8
	APORT2YCH10		PC10
	APORT2YCH16		PF0
	APORT2YCH18		PF2
	APORT2YCH20		PF4
	APORT2YCH22		PF6

Analog Module	Analog Module Channel	Shared Bus	Pin
ACMP0	APORT3XCH2	BUSCX	PD10
	APORT3XCH4		PD12
	APORT3XCH6		PD14
	APORT3XCH8		PA0
	APORT3XCH10		PA2
	APORT3XCH12		PA4
	APORT3XCH28		PB12
	APORT3XCH30		PB14
ACMP0	APORT3YCH1	BUSCY	PD9
	APORT3YCH3		PD11
	APORT3YCH5		PD13
	APORT3YCH7		PD15
	APORT3YCH9		PA1
	APORT3YCH11		PA3
	APORT3YCH13		PA5
	APORT3YCH27		PB11
	APORT3YCH29		PB13
	APORT3YCH31		PB15
ACMP0	APORT4XCH1	BUSDX	PD9
	APORT4XCH3		PD11
	APORT4XCH5		PD13
	APORT4XCH7		PD15
	APORT4XCH9		PA1
	APORT4XCH11		PA3
	APORT4XCH13		PA5
	APORT4XCH27		PB11
	APORT4XCH29		PB13
	APORT4XCH31		PB15
ACMP0	APORT4YCH2	BUSDY	PD10
	APORT4YCH4		PD12
	APORT4YCH6		PD14
	APORT4YCH8		PA0
	APORT4YCH10		PA2
	APORT4YCH12		PA4
	APORT4YCH28		PB12
	APORT4YCH30		PB14

Analog Module	Analog Module Channel	Shared Bus	Pin
ACMP1	APORT1XCH6	BUSAX	PC6
	APORT1XCH8		PC8
	APORT1XCH10		PC10
	APORT1XCH16		PF0
	APORT1XCH18		PF2
	APORT1XCH20		PF4
	APORT1XCH22		PF6
ACMP1	APORT1YCH7	BUSAY	PC7
	APORT1YCH9		PC9
	APORT1YCH11		PC11
	APORT1YCH17		PF1
	APORT1YCH19		PF3
	APORT1YCH21		PF5
	APORT1YCH23		PF7
ACMP1	APORT2XCH7	BUSBX	PC7
	APORT2XCH9		PC9
	APORT2XCH11		PC11
	APORT2XCH17		PF1
	APORT2XCH19		PF3
	APORT2XCH21		PF5
	APORT2XCH23		PF7
ACMP1	APORT2YCH6	BUSBY	PC6
	APORT2YCH8		PC8
	APORT2YCH10		PC10
	APORT2YCH16		PF0
	APORT2YCH18		PF2
	APORT2YCH20		PF4
	APORT2YCH22		PF6
ACMP1	APORT3XCH2	BUSCX	PD10
	APORT3XCH4		PD12
	APORT3XCH6		PD14
	APORT3XCH8		PA0
	APORT3XCH10		PA2
	APORT3XCH12		PA4
	APORT3XCH28		PB12
	APORT3XCH30		PB14

Analog Module	Analog Module Channel	Shared Bus	Pin
ACMP1	APORT3YCH1	BUSCY	PD9
	APORT3YCH3		PD11
	APORT3YCH5		PD13
	APORT3YCH7		PD15
	APORT3YCH9		PA1
	APORT3YCH11		PA3
	APORT3YCH13		PA5
	APORT3YCH27		PB11
	APORT3YCH29		PB13
	APORT3YCH31		PB15
ACMP1	APORT4XCH1	BUSDX	PD9
	APORT4XCH3		PD11
	APORT4XCH5		PD13
	APORT4XCH7		PD15
	APORT4XCH9		PA1
	APORT4XCH11		PA3
	APORT4XCH13		PA5
	APORT4XCH27		PB11
	APORT4XCH29		PB13
	APORT4XCH31		PB15
ACMP1	APORT4YCH2	BUSDY	PD10
	APORT4YCH4		PD12
	APORT4YCH6		PD14
	APORT4YCH8		PA0
	APORT4YCH10		PA2
	APORT4YCH12		PA4
	APORT4YCH28		PB12
	APORT4YCH30		PB14
ADC0	APORT1XCH6	BUSAX	PC6
	APORT1XCH8		PC8
	APORT1XCH10		PC10
	APORT1XCH16		PF0
	APORT1XCH18		PF2
	APORT1XCH20		PF4
	APORT1XCH22		PF6

Analog Module	Analog Module Channel	Shared Bus	Pin
ADC0	APORT1YCH7	BUSAY	PC7
	APORT1YCH9		PC9
	APORT1YCH11		PC11
	APORT1YCH17		PF1
	APORT1YCH19		PF3
	APORT1YCH21		PF5
	APORT1YCH23		PF7
ADC0	APORT2XCH7	BUSBX	PC7
	APORT2XCH9		PC9
	APORT2XCH11		PC11
	APORT2XCH17		PF1
	APORT2XCH19		PF3
	APORT2XCH21		PF5
	APORT2XCH23		PF7
ADC0	APORT2YCH6	BUSBY	PC6
	APORT2YCH8		PC8
	APORT2YCH10		PC10
	APORT2YCH16		PF0
	APORT2YCH18		PF2
	APORT2YCH20		PF4
	APORT2YCH22		PF6
ADC0	APORT3XCH2	BUSCX	PD10
	APORT3XCH4		PD12
	APORT3XCH6		PD14
	APORT3XCH8		PA0
	APORT3XCH10		PA2
	APORT3XCH12		PA4
	APORT3XCH28		PB12
	APORT3XCH30		PB14

Analog Module	Analog Module Channel	Shared Bus	Pin
ADC0	APORT3YCH1	BUSCY	PD9
	APORT3YCH3		PD11
	APORT3YCH5		PD13
	APORT3YCH7		PD15
	APORT3YCH9		PA1
	APORT3YCH11		PA3
	APORT3YCH13		PA5
	APORT3YCH27		PB11
	APORT3YCH29		PB13
	APORT3YCH31		PB15
ADC0	APORT4XCH1	BUSDX	PD9
	APORT4XCH3		PD11
	APORT4XCH5		PD13
	APORT4XCH7		PD15
	APORT4XCH9		PA1
	APORT4XCH11		PA3
	APORT4XCH13		PA5
	APORT4XCH27		PB11
	APORT4XCH29		PB13
	APORT4XCH31		PB15
ADC0	APORT4YCH2	BUSDY	PD10
	APORT4YCH4		PD12
	APORT4YCH6		PD14
	APORT4YCH8		PA0
	APORT4YCH10		PA2
	APORT4YCH12		PA4
	APORT4YCH28		PB12
	APORT4YCH30		PB14
IDAC0	APORT1XCH2	BUSCX	PD10
	APORT1XCH4		PD12
	APORT1XCH6		PD14
	APORT1XCH8		PA0
	APORT1XCH10		PA2
	APORT1XCH12		PA4
	APORT1XCH28		PB12
	APORT1XCH30		PB14

Analog Module	Analog Module Channel	Shared Bus	Pin
IDAC0	APORT1YCH1	BUSCY	PD9
	APORT1YCH3		PD11
	APORT1YCH5		PD13
	APORT1YCH7		PD15
	APORT1YCH9		PA1
	APORT1YCH11		PA3
	APORT1YCH13		PA5
	APORT1YCH27		PB11
	APORT1YCH29		PB13
	APORT1YCH31		PB15

## 7. QFN48 Package Specifications

### 7.1 QFN48 Package Dimensions

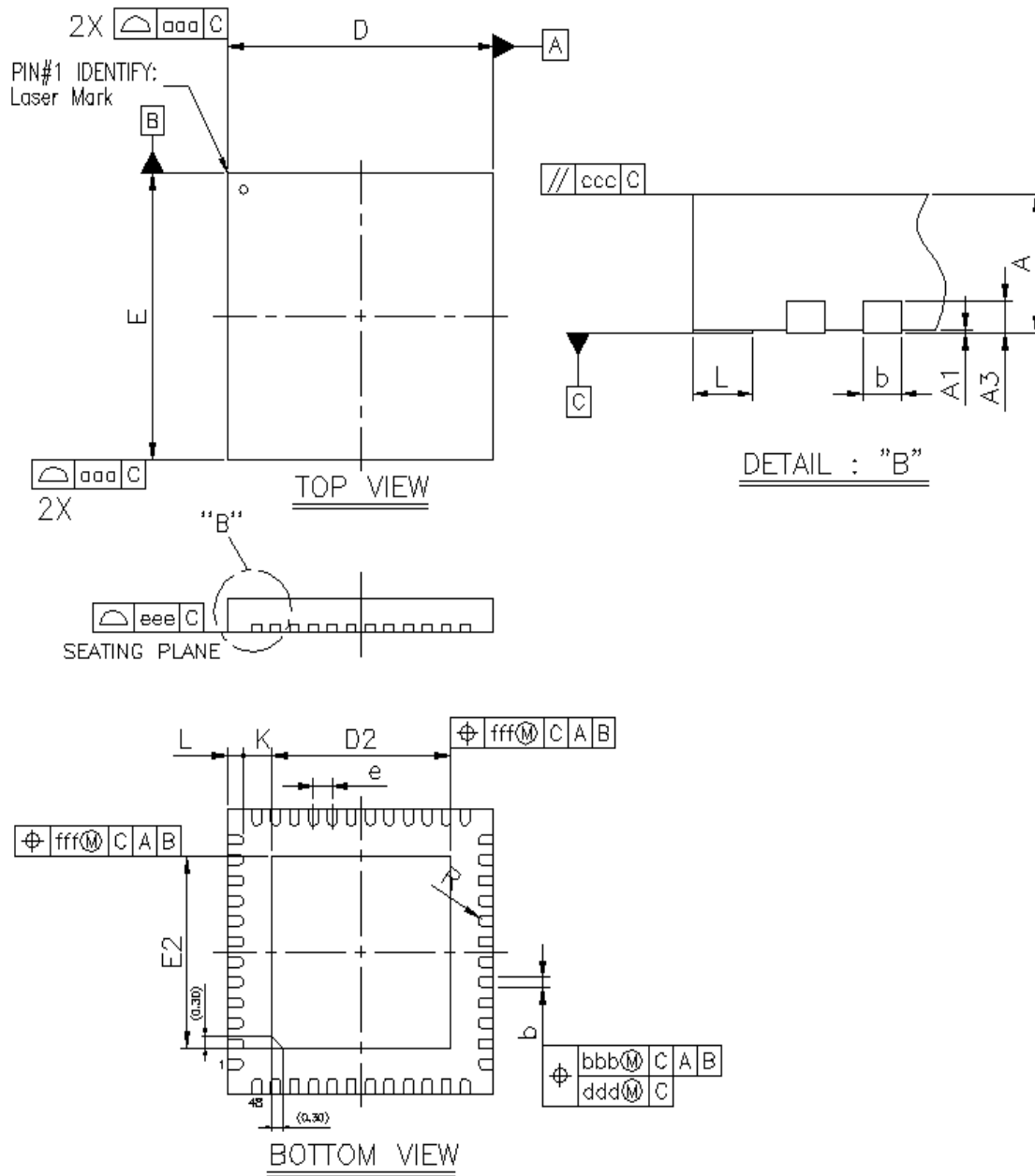

Figure 7.1. QFN48 Package Drawing



**Table 7.1. QFN48 Package Dimensions**

Dimension	Min	Typ	Max
A	0.80	0.85	0.90
A1	0.00	0.02	0.05
A3	0.20 REF		
b	0.18	0.25	0.30
D	6.90	7.00	7.10
E	6.90	7.00	7.10
D2	4.60	4.70	4.80
E2	4.60	4.70	4.80
e	0.50 BSC		
L	0.30	0.40	0.50
K	0.20	—	—
R	0.09	—	0.14
aaa	0.15		
bbb	0.10		
ccc	0.10		
ddd	0.05		
eee	0.08		
fff	0.10		

**Note:**

1. All dimensions shown are in millimeters (mm) unless otherwise noted.
2. Dimensioning and Tolerancing per ANSI Y14.5M-1994.
3. This drawing conforms to the JEDEC Solid State Outline MO-220, Variation VKKD-4.
4. Recommended card reflow profile is per the JEDEC/IPC J-STD-020 specification for Small Body Components.

### 7.2 QFN48 PCB Land Pattern

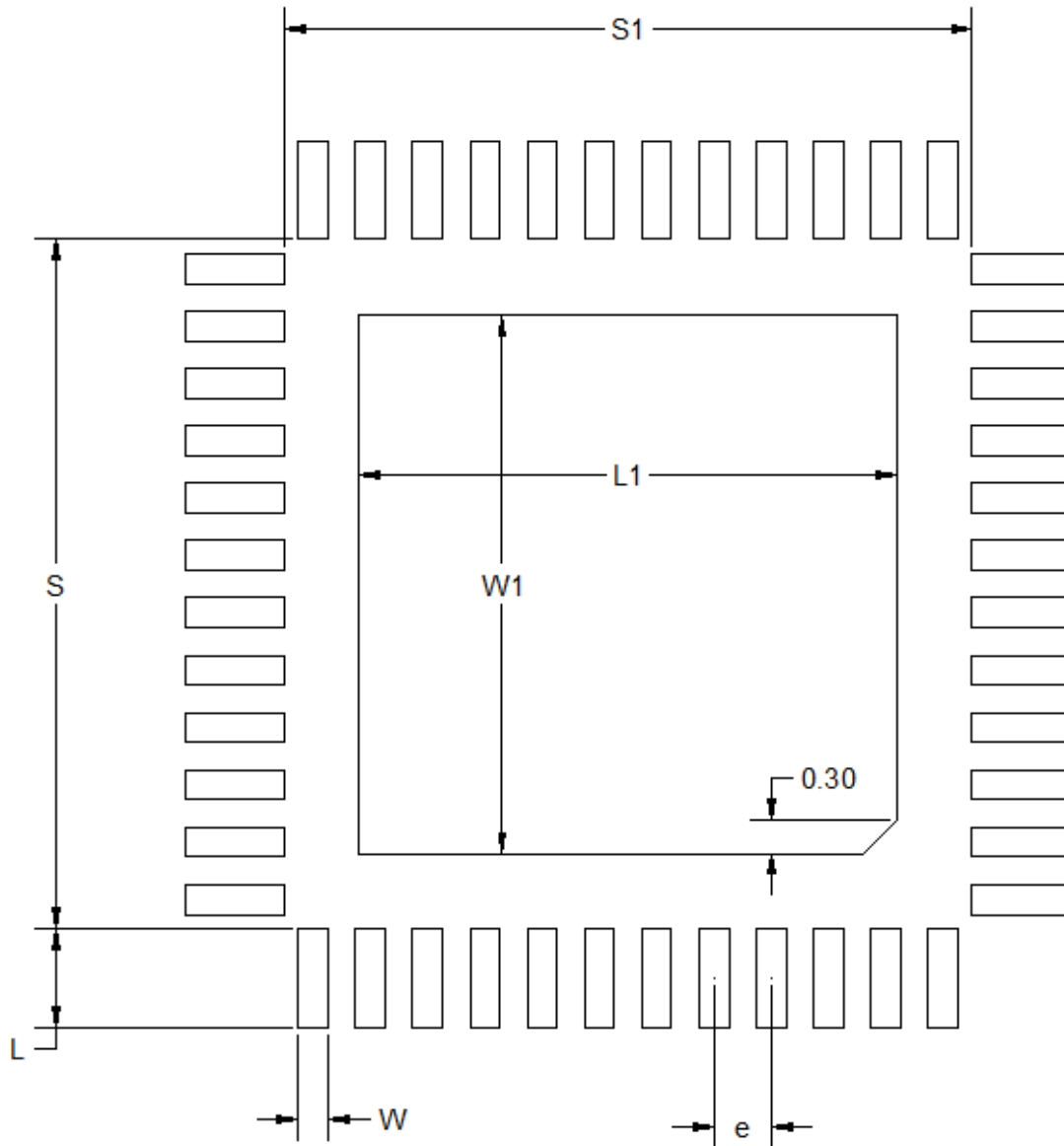

Figure 7.2. QFN48 PCB Land Pattern Drawing

Table 7.2. QFN48 PCB Land Pattern Dimensions

Dimension	Typ
S1	6.01
S	6.01
L1	4.70
W1	4.70
e	0.50
W	0.26
L	0.86

**Note:**

1. All dimensions shown are in millimeters (mm) unless otherwise noted.
2. This Land Pattern Design is based on the IPC-7351 guidelines.
3. All metal pads are to be non-solder mask defined (NSMD). Clearance between the solder mask and the metal pad is to be 60  $\mu\text{m}$  minimum, all the way around the pad.
4. A stainless steel, laser-cut and electro-polished stencil with trapezoidal walls should be used to assure good solder paste release.
5. The stencil thickness should be 0.125 mm (5 mils).
6. The ratio of stencil aperture to land pad size can be 1:1 for all perimeter pads.
7. A 4x4 array of 0.75 mm square openings on a 1.00 mm pitch can be used for the center ground pad.
8. A No-Clean, Type-3 solder paste is recommended.
9. The recommended card reflow profile is per the JEDEC/IPC J-STD-020 specification for Small Body Components.

### 7.3 QFN48 Package Marking



**Figure 7.3. QFN48 Package Marking**

The package marking consists of:

- P P P P P P P P P P – The part number designation.
- T T T T T T – A trace or manufacturing code. The first letter is the device revision.
- Y Y – The last 2 digits of the assembly year.
- W W – The 2-digit workweek when the device was assembled.
- # – Reserved for future use. Current value is 0.

## 8. QFN32 Package Specifications

### 8.1 QFN32 Package Dimensions

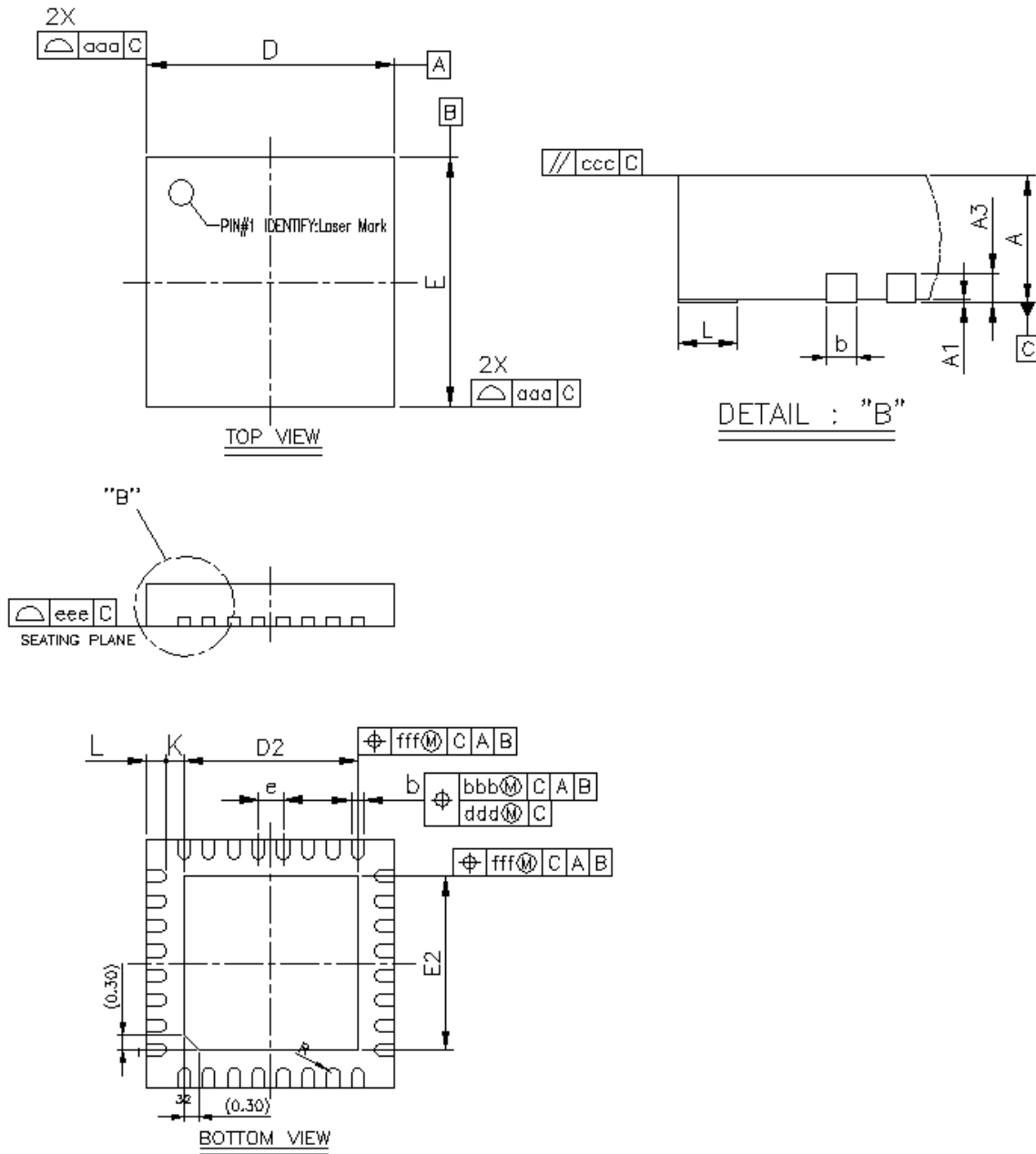

Figure 8.1. QFN32 Package Drawing

**Table 8.1. QFN32 Package Dimensions**

Dimension	Min	Typ	Max
A	0.80	0.85	0.90
A1	0.00	0.02	0.05
A3	0.20 REF		
b	0.18	0.25	0.30
D/E	4.90	5.00	5.10
D2/E2	3.40	3.50	3.60
E	0.50 BSC		
L	0.30	0.40	0.50
K	0.20	—	—
R	0.09	—	0.14
aaa	0.15		
bbb	0.10		
ccc	0.10		
ddd	0.05		
eee	0.08		
fff	0.10		

**Note:**

1. All dimensions shown are in millimeters (mm) unless otherwise noted.
2. Dimensioning and Tolerancing per ANSI Y14.5M-1994.
3. This drawing conforms to the JEDEC Solid State Outline MO-220, Variation VKKD-4.
4. Recommended card reflow profile is per the JEDEC/IPC J-STD-020 specification for Small Body Components.

## 8.2 QFN32 PCB Land Pattern

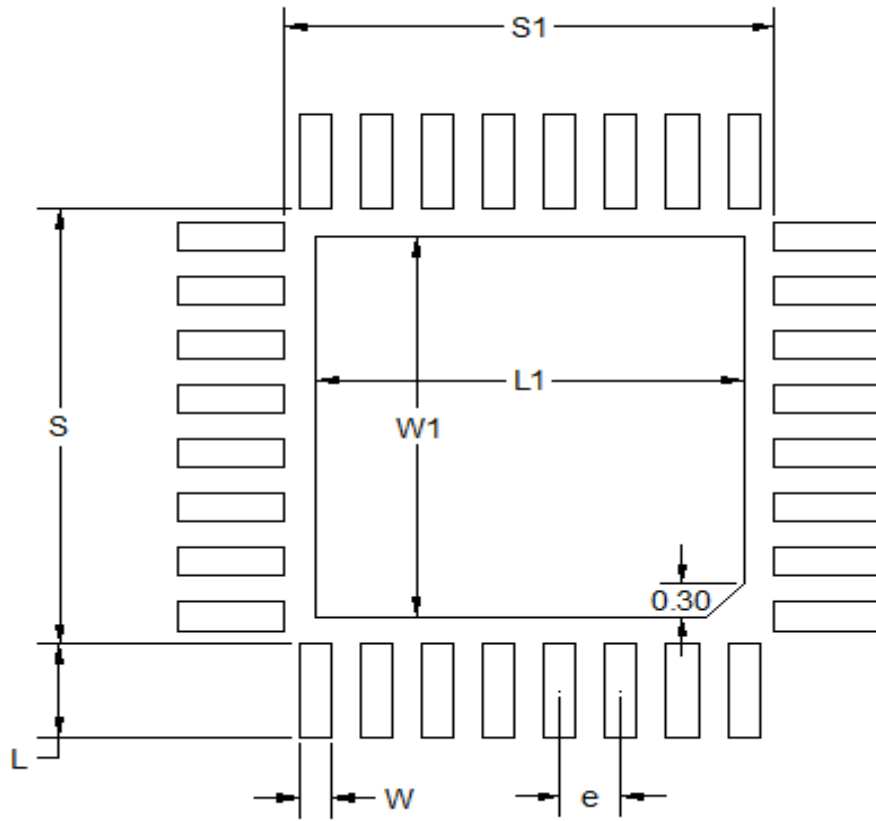

Figure 8.2. QFN32 PCB Land Pattern Drawing

Table 8.2. QFN32 PCB Land Pattern Dimensions

Dimension	Typ
S1	4.01
S	4.01
L1	3.50
W1	3.50
e	0.50
W	0.26
L	0.86

**Note:**

1. All dimensions shown are in millimeters (mm) unless otherwise noted.
2. This Land Pattern Design is based on the IPC-7351 guidelines.
3. All metal pads are to be non-solder mask defined (NSMD). Clearance between the solder mask and the metal pad is to be 60  $\mu\text{m}$  minimum, all the way around the pad.
4. A stainless steel, laser-cut and electro-polished stencil with trapezoidal walls should be used to assure good solder paste release.
5. The stencil thickness should be 0.125 mm (5 mils).
6. The ratio of stencil aperture to land pad size can be 1:1 for all perimeter pads.
7. A 3x3 array of 0.85 mm square openings on a 1.00 mm pitch can be used for the center ground pad.
8. A No-Clean, Type-3 solder paste is recommended.
9. The recommended card reflow profile is per the JEDEC/IPC J-STD-020 specification for Small Body Components.



### 8.3 QFN32 Package Marking



Figure 8.3. QFN32 Package Marking

The package marking consists of:

- P P P P P P P P P P – The part number designation.
- T T T T T T – A trace or manufacturing code. The first letter is the device revision.
- Y Y – The last 2 digits of the assembly year.
- W W – The 2-digit workweek when the device was assembled.
- # – Reserved for future use. Current value is 0.

## 9. Revision History

### 9.1 Revision 0.31

- Engineering samples note added to ordering information table.

### 9.2 Revision 0.3

- Re-formatted ordering information table and OPN decoder.
- Removed extraneous sections from dc-dc from system overview.
- Updated table formatting for electrical specifications.
- Updated electrical specifications with latest available data.
- Added I2C and USART SPI timing tables.
- Moved dc-dc graph to typical performance curves.
- Updated APORT tables and APORT references to correct nomenclature.
- Updated top marking description.

### 9.3 Revision 0.2

Updated ordering table.

Changed "1.62 V to 3.8 V Single Power Supply" to "1.62 V to 3.8 V Power Supply" in the Feature List.

### 9.4 Revision 0.1

Initial release.

<b>1. Feature List</b>	<b>1</b>
<b>2. Ordering Information</b>	<b>2</b>
<b>3. System Overview</b>	<b>3</b>
3.1 Introduction	3
3.2 Power	4
3.2.1 Energy Management Unit (EMU)	4
3.2.2 DC-DC Converter	4
3.3 General Purpose Input/Output (GPIO)	4
3.4 Clocking	4
3.4.1 Clock Management Unit (CMU)	4
3.4.2 Internal and External Oscillators	4
3.5 Counters/Timers and PWM	5
3.5.1 Timer/Counter (TIMER)	5
3.5.2 Real Time Counter and Calendar (RTCC)	5
3.5.3 Low Energy Timer (LETIMER)	5
3.5.4 Ultra Low Power Wake-up Timer (CRYOTIMER)	5
3.5.5 Pulse Counter (PCNT)	5
3.5.6 Watchdog Timer (WDOG)	5
3.6 Communications and Other Digital Peripherals	5
3.6.1 Universal Synchronous/Asynchronous Receiver/Transmitter (USART)	5
3.6.2 Low Energy Universal Asynchronous Receiver/Transmitter (LEUART)	6
3.6.3 Inter-Integrated Circuit Interface (I <sup>2</sup> C)	6
3.6.4 Peripheral Reflex System (PRS)	6
3.7 Security Features	6
3.7.1 GPCRC (General Purpose Cyclic Redundancy Check)	6
3.7.2 Crypto Accelerator (CRYPTO)	6
3.8 Analog	6
3.8.1 Analog Port (APORT)	6
3.8.2 Analog Comparator (ACMP)	6
3.8.3 Analog to Digital Converter (ADC)	7
3.8.4 Digital to Analog Current Converter (IDAC)	7
3.9 Reset Management Unit (RMU)	7
3.10 Core and Memory	7
3.10.1 Processor Core	7
3.10.2 Memory System Controller (MSC)	7
3.10.3 Linked Direct Memory Access Controller (LDMA)	7
3.11 Memory Map	8
3.12 Configuration Summary	9
<b>4. Electrical Specifications</b>	<b>10</b>
4.1 Electrical Characteristics	10
4.1.1 Absolute Maximum Ratings	10
4.1.2 Operating Conditions	11

4.1.2.1	General Operating Conditions	.11
4.1.3	DC-DC Converter	.12
4.1.4	Current Consumption	.14
4.1.4.1	Current Consumption 1.85V without DC/DC	.14
4.1.4.2	Current Consumption 3.3V without DC/DC	.15
4.1.4.3	Current Consumption 3.3V with DC/DC	.16
4.1.5	Wake up times	.17
4.1.6	Brown Out Detector	.17
4.1.7	Oscillators	.18
4.1.7.1	LFXO	.18
4.1.7.2	HFXO	.19
4.1.7.3	LFRCO	.19
4.1.7.4	HFRCO and AUXHFRCO	.20
4.1.7.5	ULFRCO	.21
4.1.8	Flash Memory Characteristics	.21
4.1.9	GPIO	.22
4.1.10	VMON	.23
4.1.11	ADC	.24
4.1.12	IDAC	.26
4.1.13	Analog Comparator (ACMP)	.28
4.1.14	I2C	.30
4.1.15	USART SPI	.32
4.2	Typical Performance Curves	.34
<b>5.</b>	<b>Typical Connection Diagrams</b>	<b>35</b>
5.1	Power	.35
5.2	Other Connections	.36
<b>6.</b>	<b>Pin Definitions</b>	<b>37</b>
6.1	EFM32PG1 QFN48 Definition	.37
6.1.1	GPIO Pinout Overview	.46
6.2	EFM32PG1 QFN32 with DC-DC Definition	.47
6.2.1	GPIO Pinout Overview	.54
6.3	EFM32PG1 QFN32 without DC-DC Definition	.55
6.3.1	GPIO Pinout Overview	.63
6.4	Alternate Functionality Pinout	.64
6.5	Analog Port (APORT)	.70
<b>7.</b>	<b>QFN48 Package Specifications</b>	<b>79</b>
7.1	QFN48 Package Dimensions	.79
7.2	QFN48 PCB Land Pattern	.81
7.3	QFN48 Package Marking	.83
<b>8.</b>	<b>QFN32 Package Specifications</b>	<b>84</b>
8.1	QFN32 Package Dimensions	.84
8.2	QFN32 PCB Land Pattern	.86
8.3	QFN32 Package Marking	.88

---

<b>9. Revision History</b>	<b>89</b>
9.1 Revision 0.31	.89
9.2 Revision 0.3	.89
9.3 Revision 0.2	.89
9.4 Revision 0.1	.89
<b>Table of Contents</b>	<b>90</b>

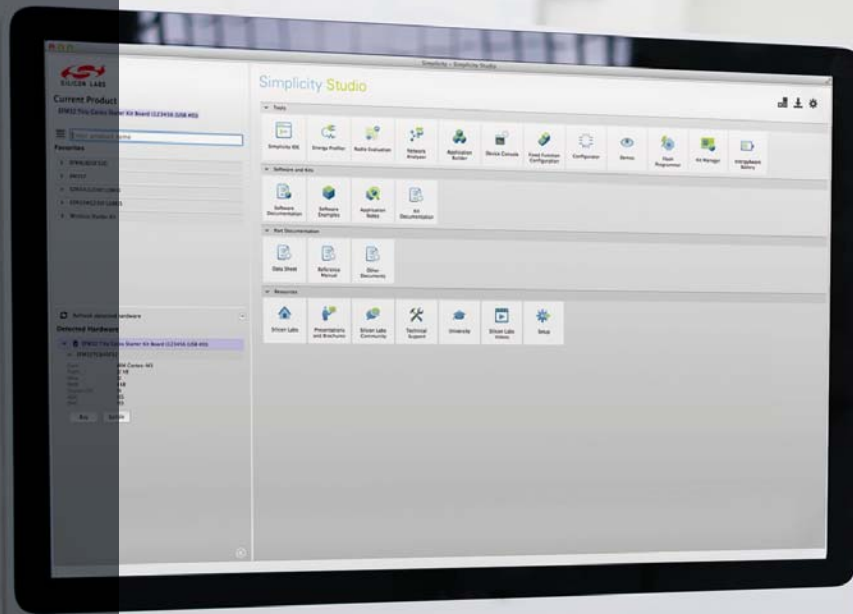

## Simplicity Studio

One-click access to MCU and wireless tools, documentation, software, source code libraries & more. Available for Windows, Mac and Linux!



**IoT Portfolio**  
[www.silabs.com/IoT](http://www.silabs.com/IoT)



**SW/HW**  
[www.silabs.com/simplicity](http://www.silabs.com/simplicity)



**Quality**  
[www.silabs.com/quality](http://www.silabs.com/quality)



**Support and Community**  
[community.silabs.com](http://community.silabs.com)

### Disclaimer

Silicon Laboratories intends to provide customers with the latest, accurate, and in-depth documentation of all peripherals and modules available for system and software implementers using or intending to use the Silicon Laboratories products. Characterization data, available modules and peripherals, memory sizes and memory addresses refer to each specific device, and "Typical" parameters provided can and do vary in different applications. Application examples described herein are for illustrative purposes only. Silicon Laboratories reserves the right to make changes without further notice and limitation to product information, specifications, and descriptions herein, and does not give warranties as to the accuracy or completeness of the included information. Silicon Laboratories shall have no liability for the consequences of use of the information supplied herein. This document does not imply or express copyright licenses granted hereunder to design or fabricate any integrated circuits. The products must not be used within any Life Support System without the specific written consent of Silicon Laboratories. A "Life Support System" is any product or system intended to support or sustain life and/or health, which, if it fails, can be reasonably expected to result in significant personal injury or death. Silicon Laboratories products are generally not intended for military applications. Silicon Laboratories products shall under no circumstances be used in weapons of mass destruction including (but not limited to) nuclear, biological or chemical weapons, or missiles capable of delivering such weapons.

### Trademark Information

Silicon Laboratories Inc., Silicon Laboratories, Silicon Labs, SiLabs and the Silicon Labs logo, CMEMS®, EFM, EFM32, EFR, Energy Micro, Energy Micro logo and combinations thereof, "the world's most energy friendly microcontrollers", Ember®, EZLink®, EZMac®, EZRadio®, EZRadioPRO®, DSPLL®, ISOModem®, Precision32®, ProSLIC®, SiPHY®, USBXpress® and others are trademarks or registered trademarks of Silicon Laboratories Inc. ARM, CORTEX, Cortex-M3 and THUMB are trademarks or registered trademarks of ARM Holdings. Keil is a registered trademark of ARM Limited. All other products or brand names mentioned herein are trademarks of their respective holders.



**SILICON LABS**

Silicon Laboratories Inc.  
 400 West Cesar Chavez  
 Austin, TX 78701  
 USA

<http://www.silabs.com>