

MITSUBISHI (OPTICAL DEVICES)

**FU-319SPA-CV6****InGaAs APD PREAMP MODULE FOR THE 1.31  $\mu\text{m}$  AND 1.55  $\mu\text{m}$  WAVELENGTH RANGE****DESCRIPTION**

FU-319SPA-CV6 is InGaAs avalanche photodiode module with GaAs preamplifier, designed for use in high-speed, long haul optical communication systems. The coaxial package contains InGaAs avalanche photodiode coupled with single-mode fiber pigtail and GaAs preamplifier.

**FEATURES**

- High-sensitivity (-33dBm typ)
- 5pin coaxial package
- Selectable single power supply voltage (+5V or -5.2V). (InGaAs avalanche photodiode and GaAs preamplifier are isolated from the case.)
- GaAs preamplifier with AGC function
- Differential output (50 $\Omega$ )

**APPLICATION**

2.5Gbps optical receiver (OC-48, STM-16)  
 Extended reach datacom and telecom applications  
 Long haul optical communication systems

**ABSOLUTE MAXIMUM RATINGS (T<sub>c</sub>=25°C)**

Parameter	Symbol	Conditions	Rating	Unit
APD Reverse voltage	VPD	VSS=0V	0~Vbr	V
APD Reverse current (CW)	I <sub>r</sub>	-	500	$\mu\text{A}$
APD Forward current (CW)	I <sub>f</sub>	-	2	mA
Power supply voltage	VDD	VSS=0V	0~7	V
Operating case temperature	T <sub>c</sub>	-	-40~+85	°C
Storage temperature	T <sub>stg</sub>	-	-40~+85	°C

Vbr: APD breakdown voltage.

**FU-319SPA-CV6****InGaAs APD PREAMP MODULE FOR THE 1.31  $\mu\text{m}$  AND 1.55  $\mu\text{m}$  WAVELENGTH RANGE****ELECTRICAL/OPTICAL CHARACTERISTICS** ( $T_c=25^\circ\text{C}$ ,  $\lambda=1.55\mu\text{m}$ ,  $V_{DD}=5\text{V}$ ,  $V_{SS}=0\text{V}$  unless otherwise noted)

Parameter	Symbol	Test Conditions	Limits			Unit
			Min.	Typ.	Max.	
Detection range	-	-	1000	-	1600	nm
Responsivity(Note 1)	R13	CW, $\lambda=1.3\mu\text{m}$ , $M=1$	0.7	0.85	-	A/W
	R15	CW, $\lambda=1.55\mu\text{m}$ , $M=1$	0.8	0.9	-	
Breakdown voltage	Vbr	$I_d=100\mu\text{A}$	35	-	75	V
Temp.coefficient of Vbr(Note 3)	$\beta$	$I_d=100\mu\text{A}$ , $T_c=-40\sim 85^\circ\text{C}$	0.1	-	0.25	%/ $^\circ\text{C}$
Transimpedance	Zt(off)	AC, $f=100\text{MHz}$ , $R_L=\text{High}$ AGC_off (Note 1)	-	1.7	-	k $\Omega$
	Zt(on)	AC, $f=100\text{MHz}$ , $R_L=\text{High}$ AGC_on	-	0.5	-	
Cutoff frequency(-3dB)	fc_High	AC, $R_L=50\Omega$ , $M=10$	1.8	-	-	GHz
	fc_Low	AC, $R_L=50\Omega$	-	-	100	kHz
Average input equivalent noise current density	in	AC, $R_L=50\Omega$ , 1MHz~1.8GHz	-	6.5	-	pA/ $\sqrt{\text{Hz}}$
Output impedance	Zo	(Differential output)	-	50	-	$\Omega$
Sensitivity	Pr	AC, $R_L=50\Omega$ , $\lambda=1.55\mu\text{m}$ , NRZ, 2.48832Gbps., PRBS=2 <sup>23</sup> -1, BER=10 <sup>-10</sup> ,	-	-33	-31	dBm
Over load power	Po	VPD=Optimum value (Note 2)	-7	-5	-	
Power supply voltage	VDD	VSS=0V	4.75	5	5.46	V
Power supply current	IDD	VDD=5V	-	35	60	mA
Optical return loss	Prtn	$\lambda=1.55\mu\text{m}$	27	-	-	dB

Note 1. Transimpedance value apply when AGC(Bit by bit) function is fully off.

Note 2. Used post-amp bandwidth is 1.86GHz, Laser source extinction ratio is 10dB.

Note 3.  $\beta = \frac{V_{br}(25^\circ\text{C} + \Delta T) - V_{br}(25^\circ\text{C})}{V_{br}(25^\circ\text{C})} \times \Delta T \times 100$  [%/ $^\circ\text{C}$ ]**OPTICAL FIBER SPECIFICATION**

Parameter	Limits	Unit
Type	SM	-
Mode field dia.	9.5 $\pm$ 1	$\mu\text{m}$
Cladding dia.	125 $\pm$ 2	$\mu\text{m}$
Jacket dia.	0.9 typ.	mm
Connector return loss	40(min)	dB

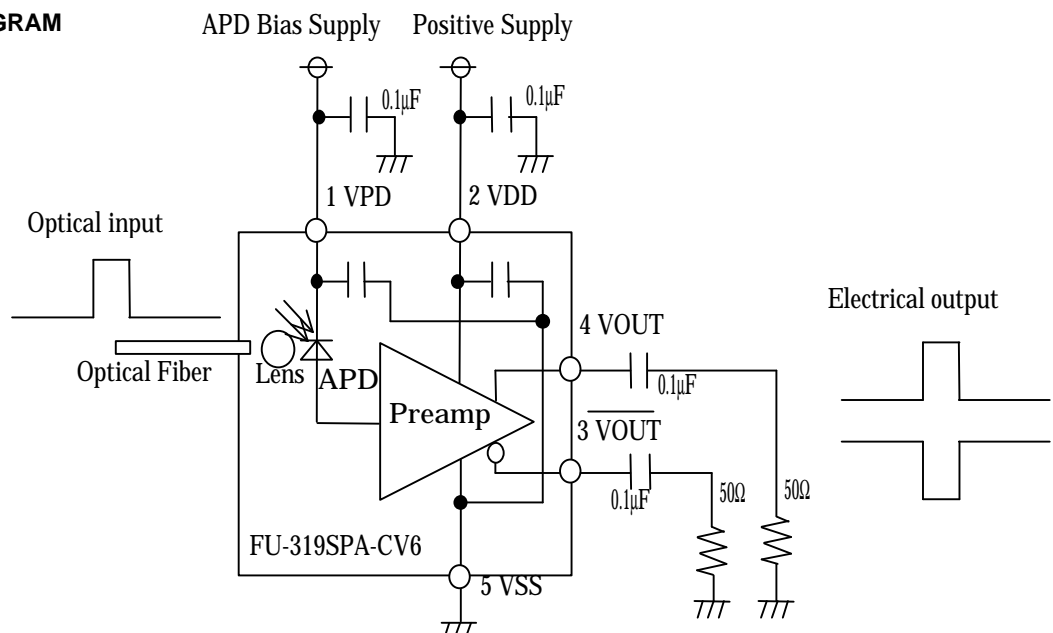
**BLOCK DIAGRAM**

MITSUBISHI (OPTICAL DEVICES)  
**FU-319SPA-CV6**

InGaAs APD PREAMP MODULE FOR THE 1.31  $\mu\text{m}$  AND 1.55  $\mu\text{m}$  WAVELENGTH RANGE

**OUTLINE DIAGRAM (FC Connector type)**

(Unit : mm)

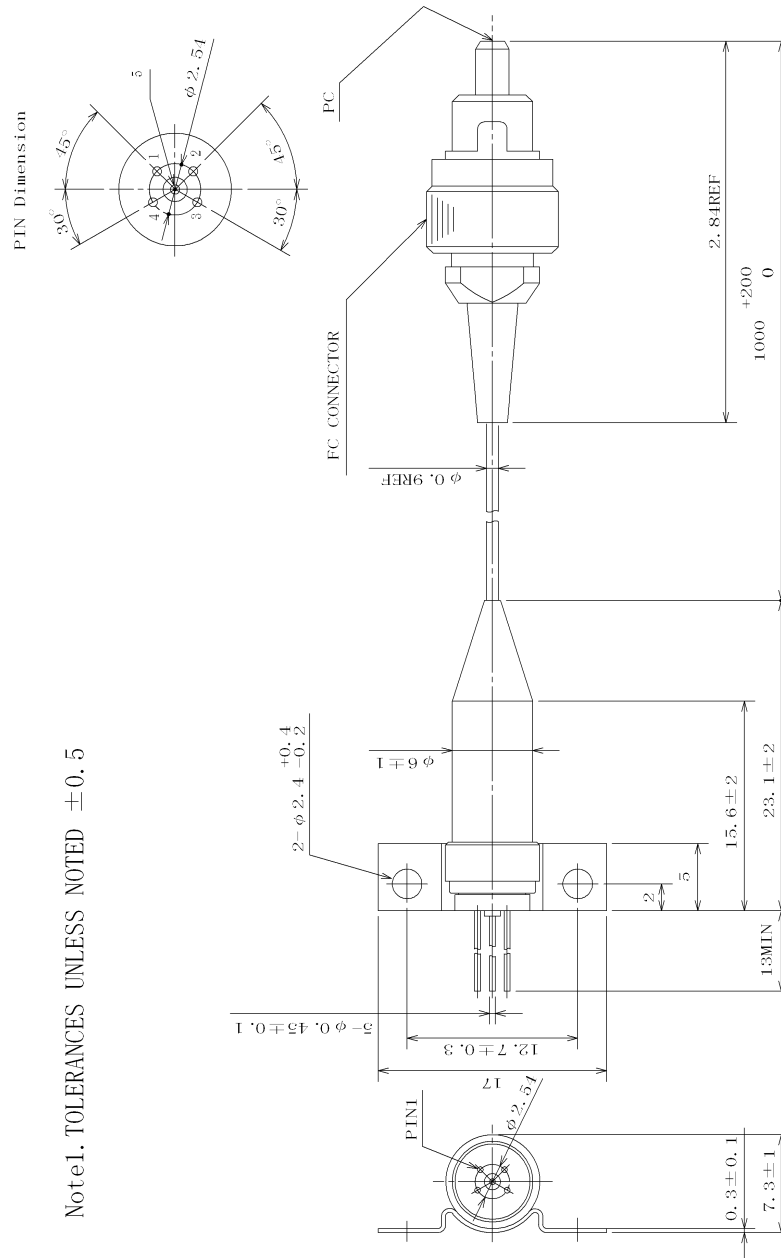

Note1. TOLERANCES UNLESS NOTED  $\pm 0.5$

- 1 : VPD
- 2 : VDD
- 3 : VOUT
- 4 : VOUT
- 5 : VSS (Isolated to the case)

**FU-319SPA-CV6**